



Ministerio de Comercio, Industria y Turismo
artesanías de colombia s.a.

Proyecto Comercial entre Artesanías de Colombia y Juan Carlos Arcila Duuqe

D1-2005.34



Ministerio de Comercio, Industria y Turismo
artesanías de colombia s.a.

Proyecto Comercial entre Artesanías de Colombia y Juan Carlos Arcila - Duque

Propuestas de Diseño
Costos de las Propuestas, Modelos y planos técnicos finales
Mayo 13 al 16 de 2005

Responsables: D.I. Alvaro Ivan Caro Niño - D.I. Jaime Eduardo Laverde

Centro *de diseño*
Colombiano *para la artesanía y las PYMES*
Subgerencia de Desarrollo

Bocetos

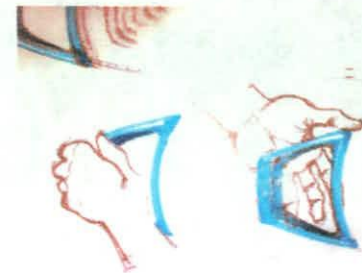
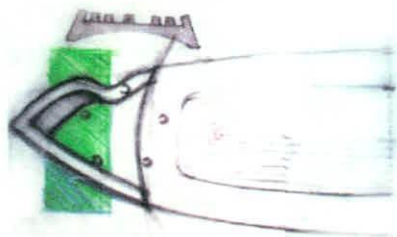
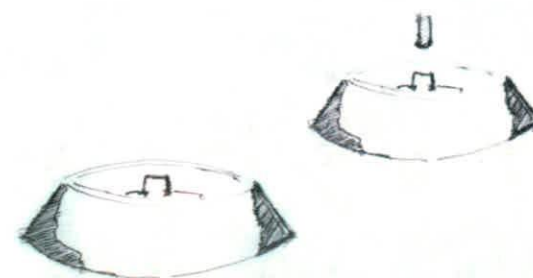



Ministerio de Comercio, Industria y Turismo
artesanías de Colombia s.a.

Proyecto Comercial entre Artesanías de Colombia y Juan Carlos Arcila
Presupuesto

Producto	Cantidad	Material	Costo	Capacidad de Produccion / Mes	Tiempo de Entrega en días	Suma proyecto 1 alpaca fique y mopamopa	Suma proyecto 2 plata fique y mopamopa	Suma proyecto 1 para elaborar dos prototipos	Suma proyecto 2 para elaborar dos prototipos
Centro de mesa Diseño Balsa	1	Alpaca y fique	\$360.000	30	10	\$360.000		\$720.000	
	1	Plata y fique	\$810.000	30	10		\$810.000		\$1.620.000
Centro de mesa Media Esfera	1	Alpaca y fique	\$140.000	3	10	\$150.000		\$300.000	
	1	Plata y fique	\$370.000	3	10		\$370.000		\$740.000
Centro de mesa Media Esfera	1	Alpaca Martillada							
	1	Plata Martillada							
Centro de Mesa ortogonal	1	Alpaca y fique	\$350.000	3	10	\$140.000		\$280.000	
	1	Plata y fique	\$800.000	3	10		\$800.000		\$1.600.000
candelabro de 160cm	1	Alpaca y tagua	\$440.000	100	8	\$440.000		\$880.000	
	1	Plata y tagua	\$600.000	100	8		\$600.000		\$1.200.000
candelabro de 150cm	1	Alpaca y tagua	\$420.000	100	8	\$420.000		\$840.000	
	1	Plata y tagua	\$620.000	100	8		\$620.000		\$1.240.000
candelabro de 120cm	1	Alpaca y tagua	\$360.000	100	8	\$360.000		\$720.000	
	1	Plata y tagua	\$460.000	100	8		\$460.000		\$920.000
candelabro de 70cm	1	Alpaca y tagua	\$280.000	100	8	\$280.000		\$560.000	
	1	Plata y tagua	\$440.000	100	8		\$440.000		\$880.000
candelabro de 50cm	1	Alpaca y tagua	\$240.000	100	8	\$240.000		\$480.000	
	1	Plata y tagua	\$420.000	100	8		\$420.000		\$840.000
Jarrón de Mopa Mopa recto alto	1	Mopa Mopa	\$120.000 a \$150.000	1	20	\$150.000	\$150.000	\$300.000	\$300.000
Jarrón de Mopa Mopa recto bajo	1	Mopa Mopa	\$100.000 a \$120.000	1	20	\$120.000	\$120.000	\$240.000	\$240.000
Jarrón de Mopa Mopa alto inclinado	1	Mopa Mopa	\$120.000 a \$150.000	1	20	\$150.000	\$150.000	\$300.000	\$300.000
Jarrón de Mopa Mopa bajo inclinado	1	Mopa Mopa	\$80.000 a \$100.000	1	20	\$100.000	\$100.000	\$200.000	\$200.000
TOTAL						\$2.910.000	\$5.040.000	\$5.820.000	\$10.080.000

Nota: en el diseño del centro de mesa balsa, no se pueden elaborar las manijas en alpaca o plata debido a que es necesario hacerlas por armado, proceso que resulta costoso. Se está cotizando el hacerlo industrialmente en aluminio o acero igual que los Bowls ortogonal y esfera debido a sus dimensiones. Es necesario aumentar en esta cotización el valor de los objetos que se están cotizando mas el 15% de imprevistos.



Ministerio de Comercio, Industria y Turismo
artesañas de colombia s.a.

Proyecto Comercial entre Artesanías de Colombia y Juan Carlos Arcila

Carta de Color



704c



153c



147 c



371c

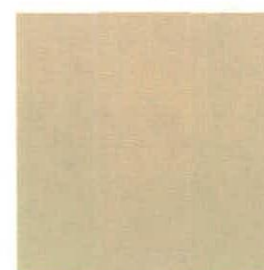

466c

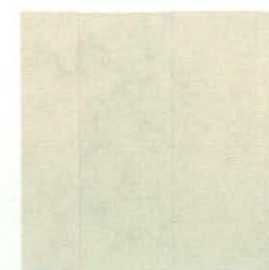

454c



7537c



Ministerio de Comercio, Industria y Turismo
artesañas de colombia s.a.

Proyecto Comercial entre Artesanías de Colombia y Juan Carlos Arcila

Bowl

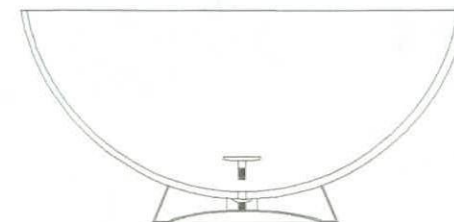
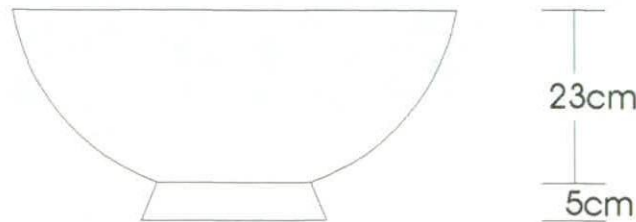
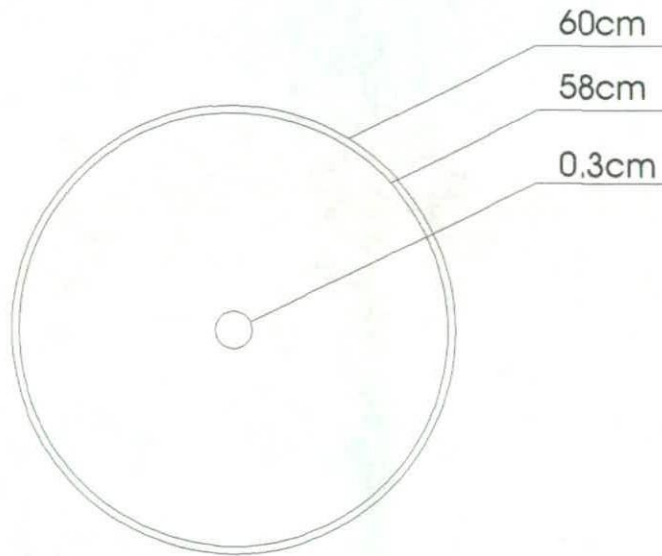

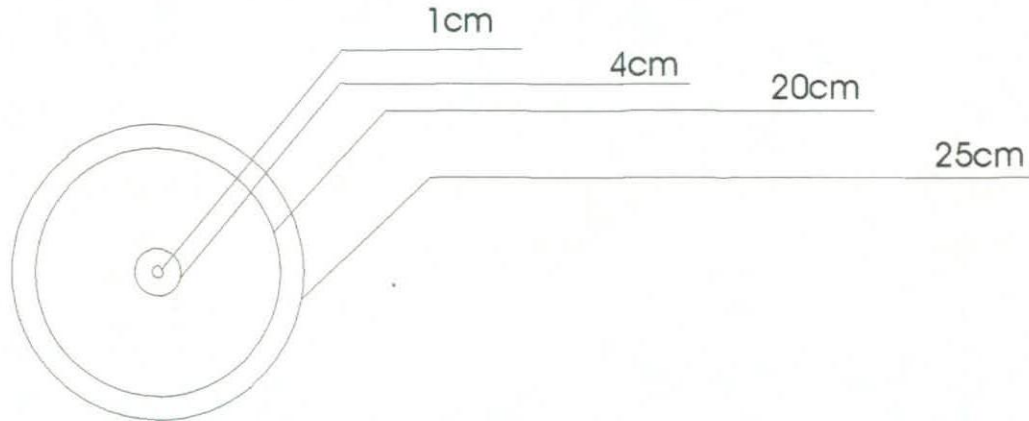

Corte

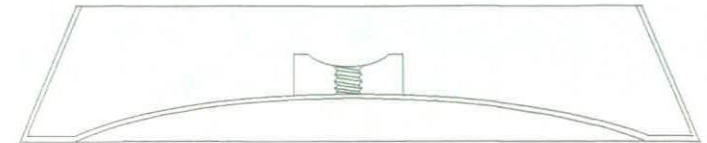

Corte

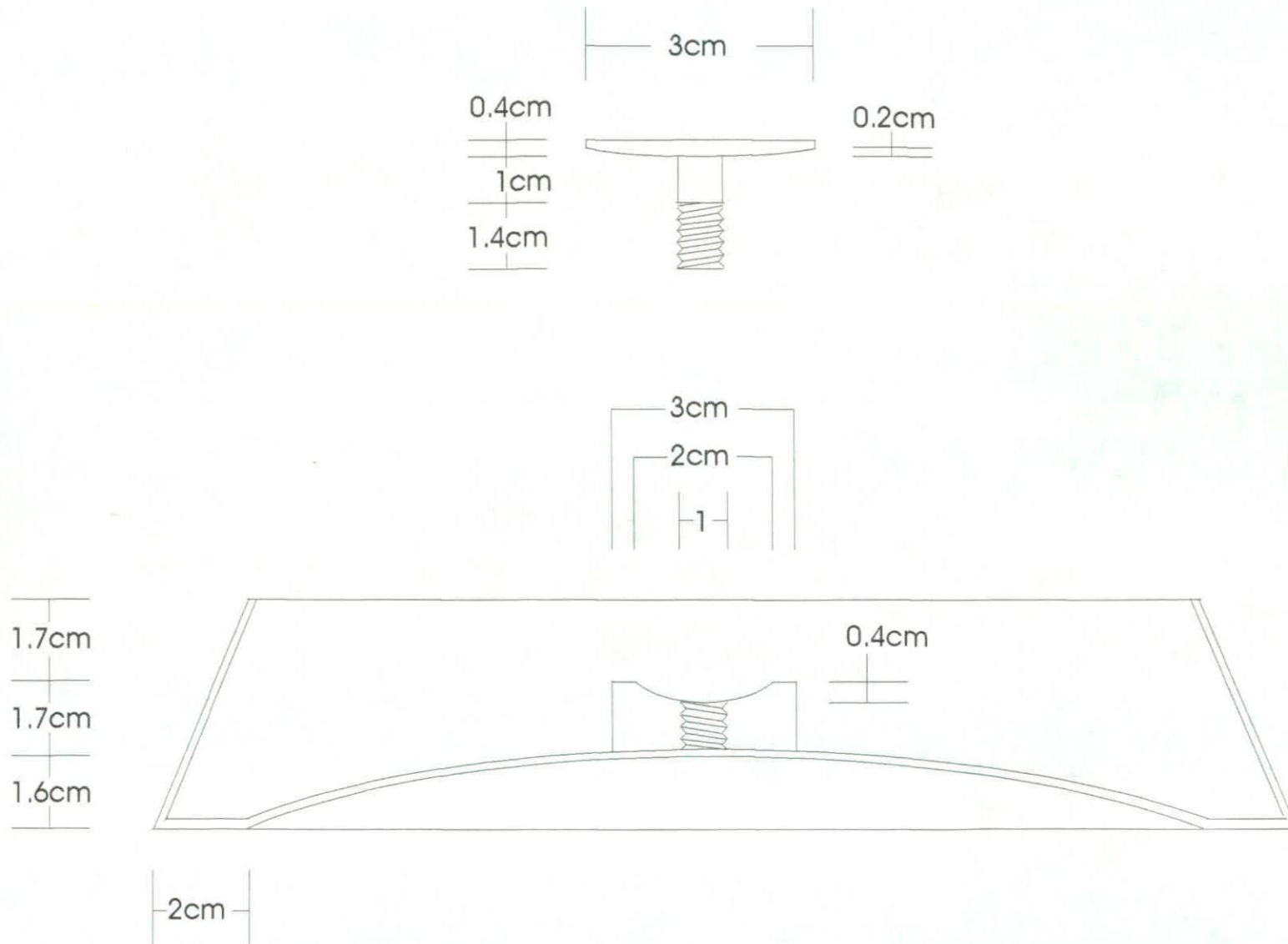



Ministerio de Comercio, Industria y Turismo
artesanas de colombia s.a.

Proyecto Comercial entre Artesanías de Colombia y Juan Carlos Arcila

Bowl

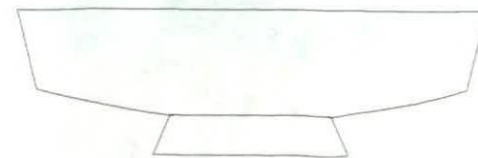
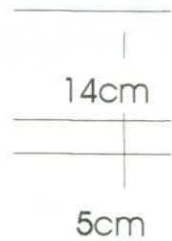
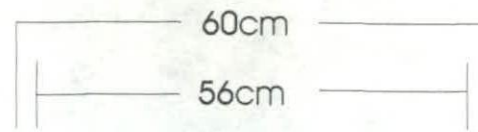
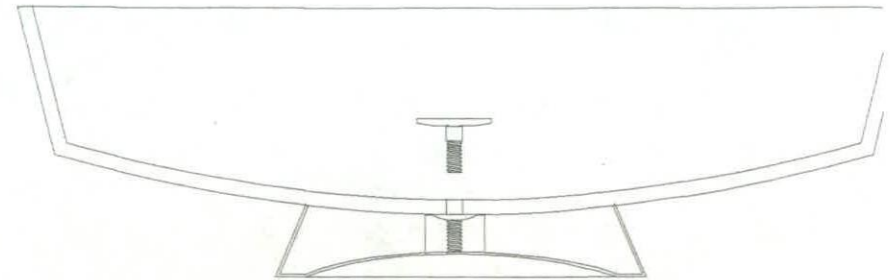
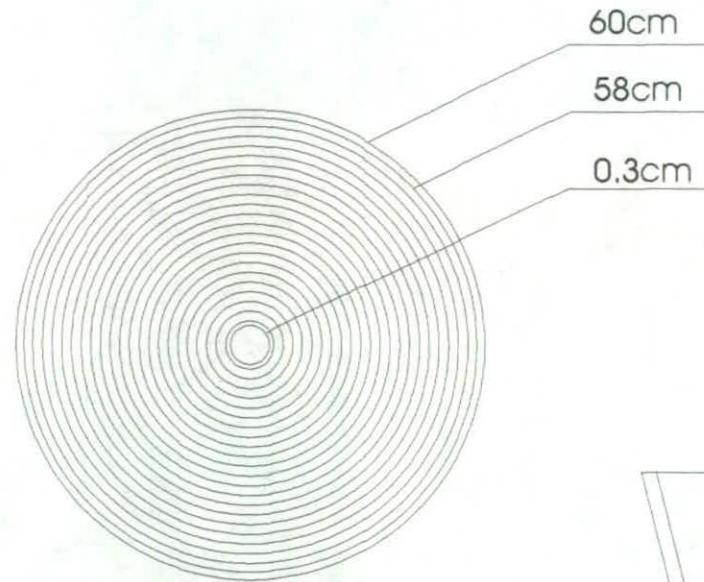



Ministerio de Comercio, Industria y Turismo
artesañas de colombia s.a.

Proyecto Comercial entre Artesanías de Colombia y Juan Carlos Arcila

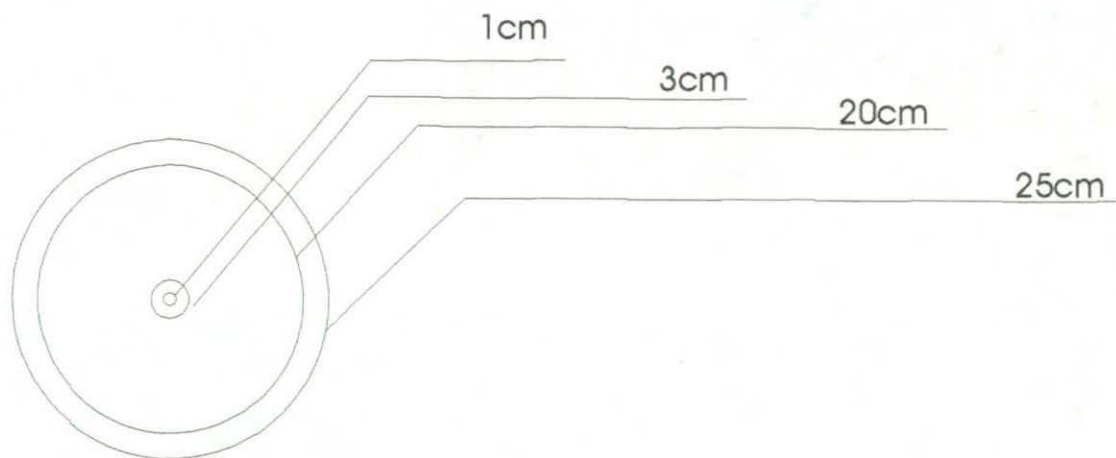

Corte

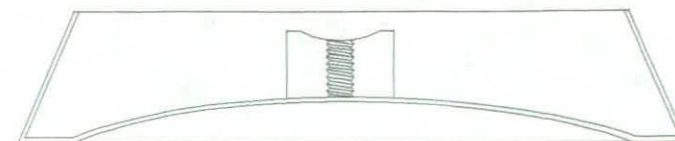

Corte

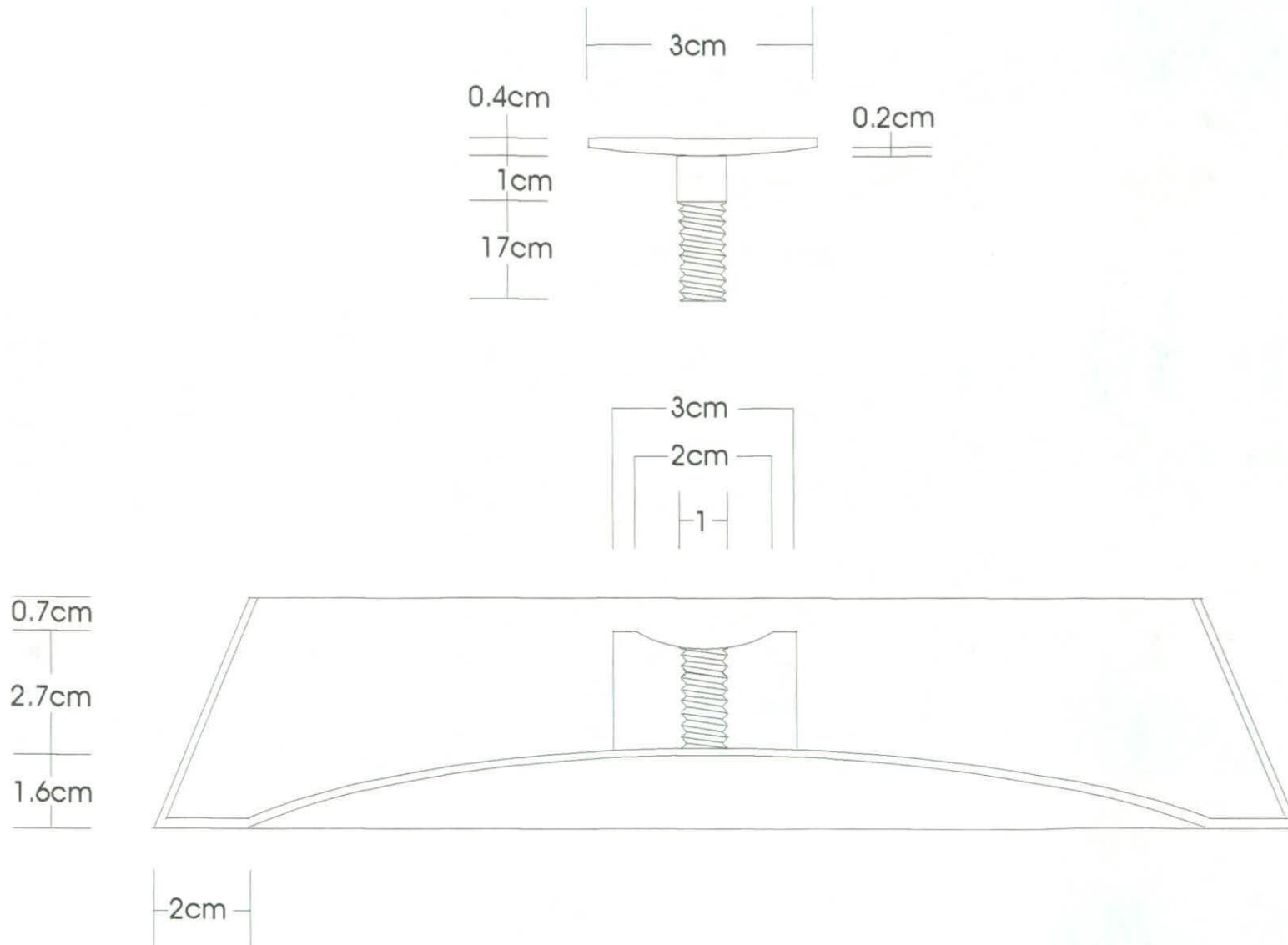



Ministerio de Comercio, Industria y Turismo
artesañas de colombia s.a.

Proyecto Comercial entre Artesanías de Colombia y Juan Carlos Arcila

Bowl

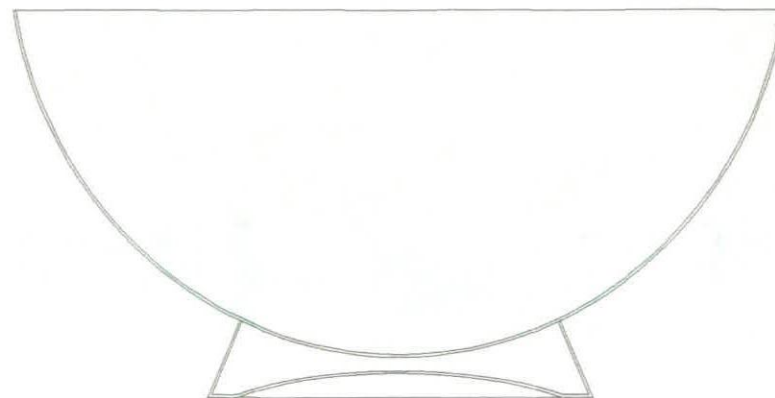
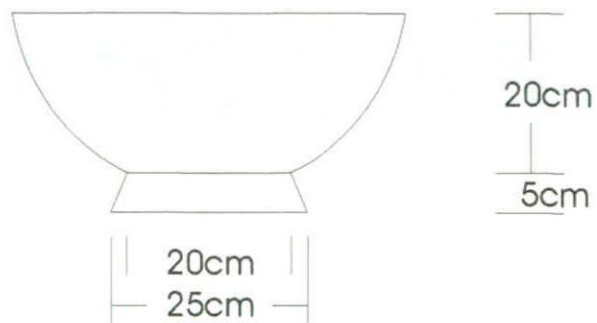
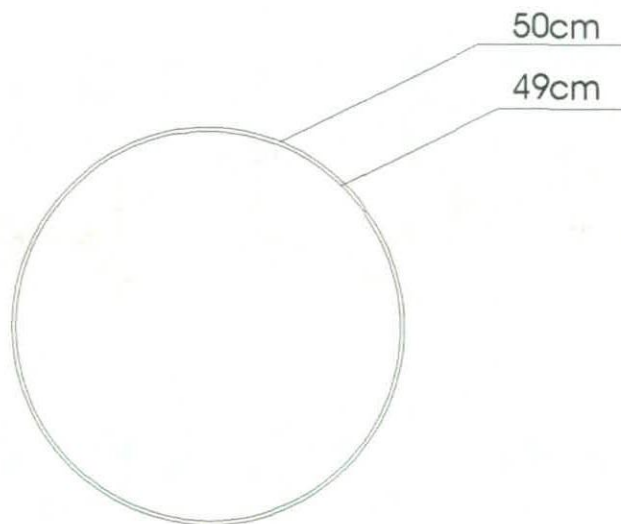



Ministerio de Comercio, Industria y Turismo
artesañas de colombia s.a.

Proyecto Comercial entre Artesanías de Colombia y Juan Carlos Arcila

Bowl

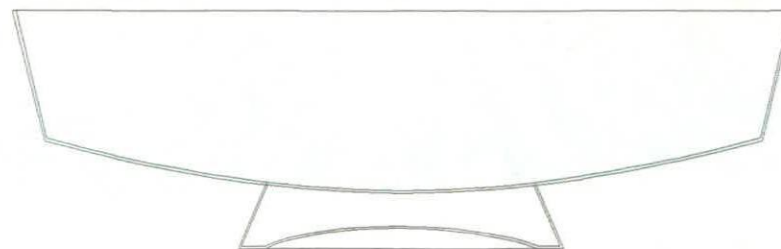
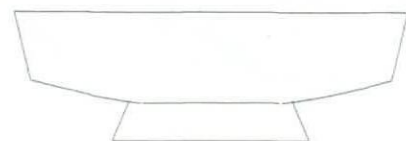
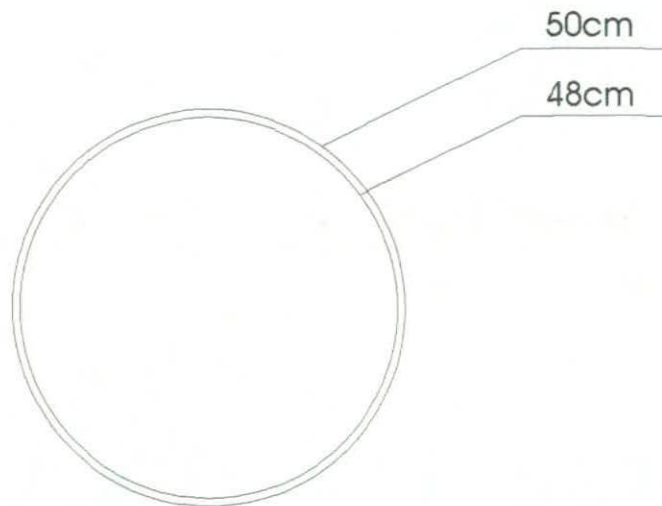



Ministerio de Comercio, Industria y Turismo
artesañas de colombia s.a.

Proyecto Comercial entre Artesanías de Colombia y
Juan Carlos Arcila



Responsable: Alvaro Ivan Caro Niño y Jaime Eduardo Laverde

Centro
Colombiano *de di*
para la artesanía y las
Subgerencia de E

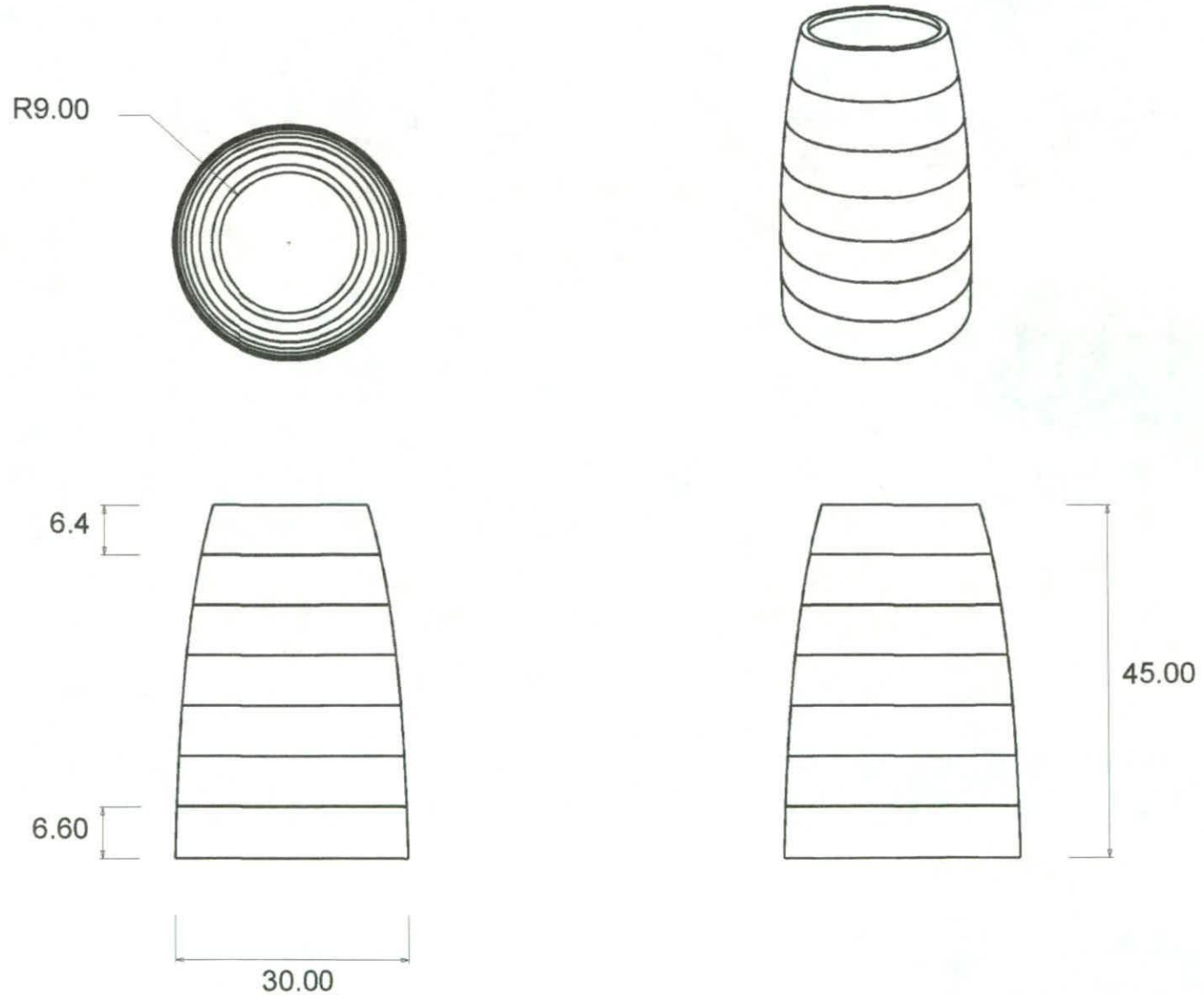

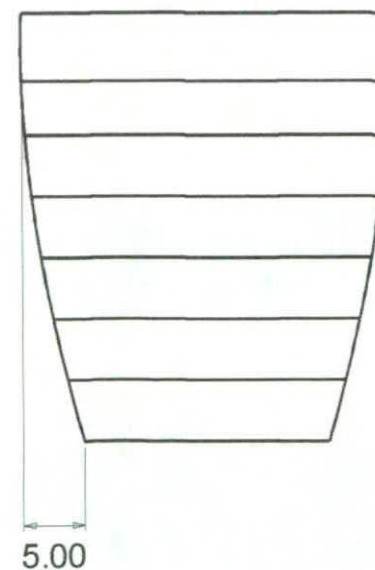
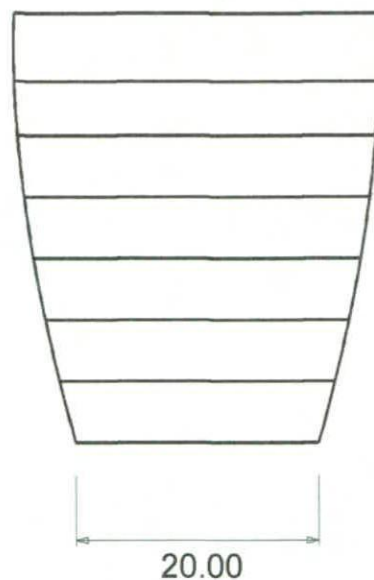
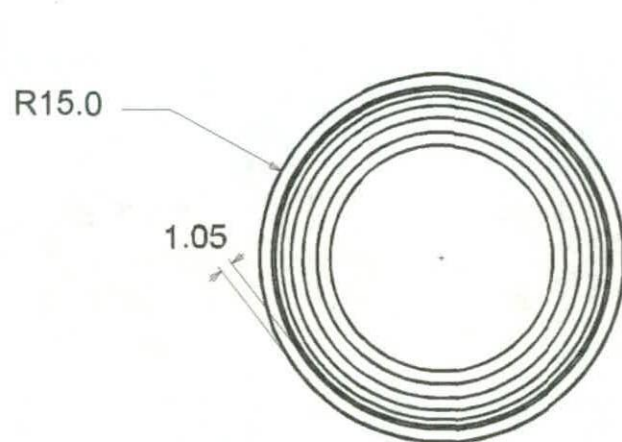



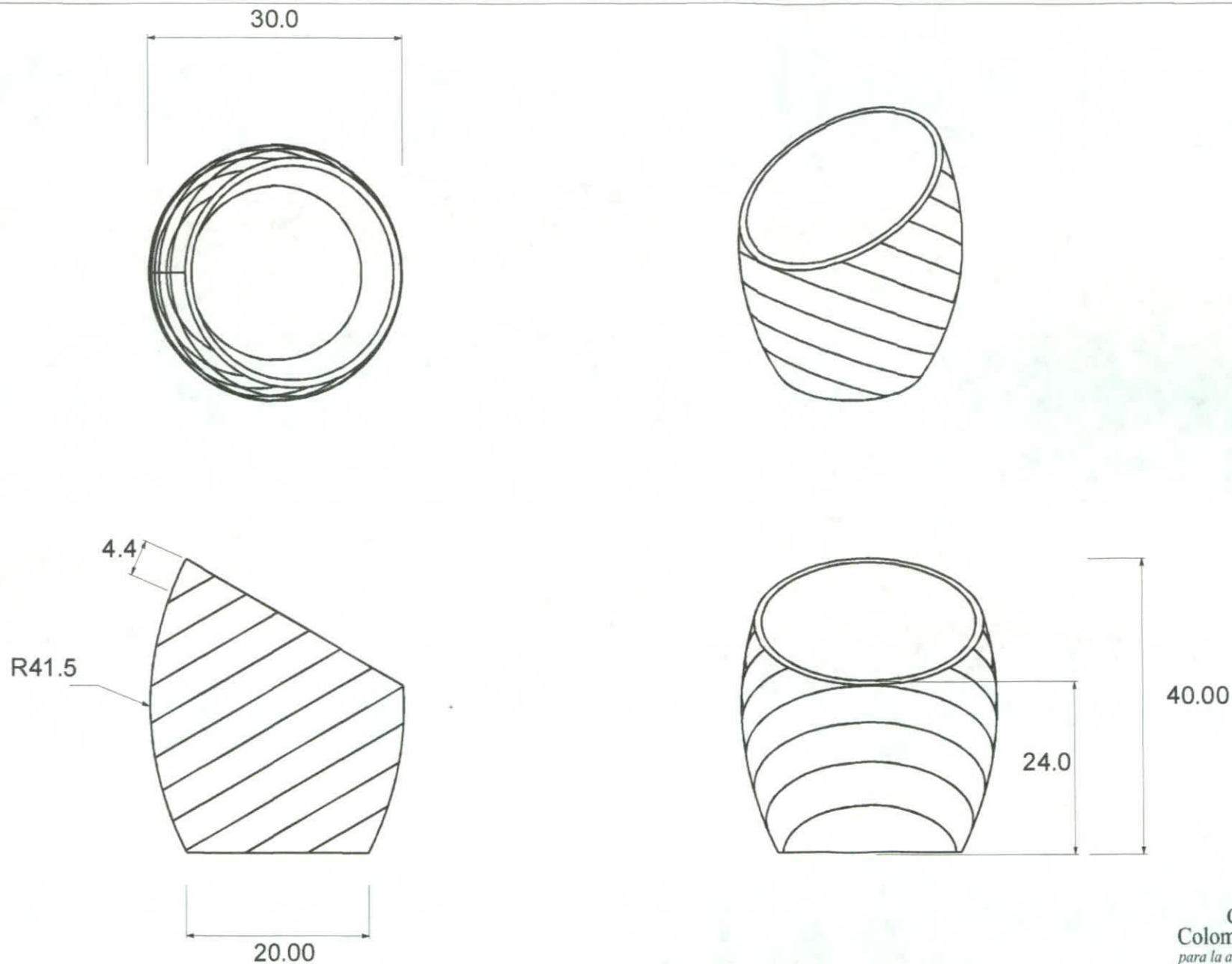



Ministerio de Comercio, Industria y Turismo
artesanas de colombia s.a.

Proyecto Comercial entre Artesanías de Colombia y
Juan Carlos Arcila

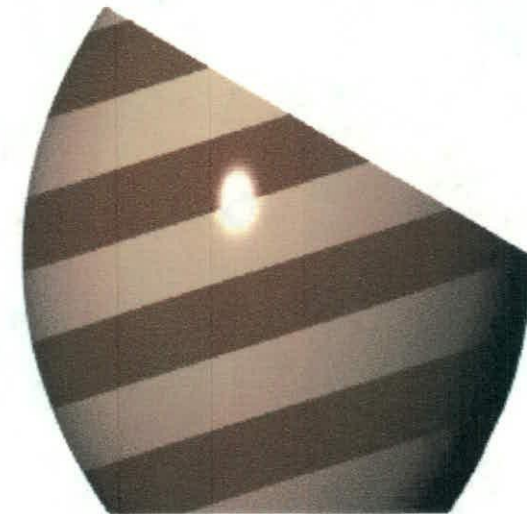
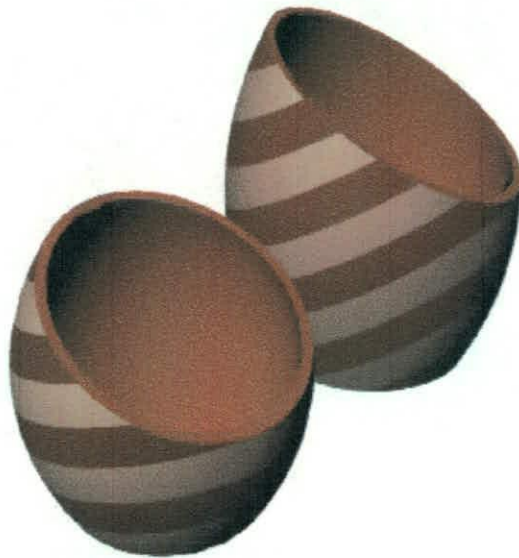

Responsable: Alvaro Ivan Caro Niño y Jaime Eduardo Laverde

Centro
Colombiano *de diseño*
para la artesanía y las PYME.
Subgerencia de Desarr

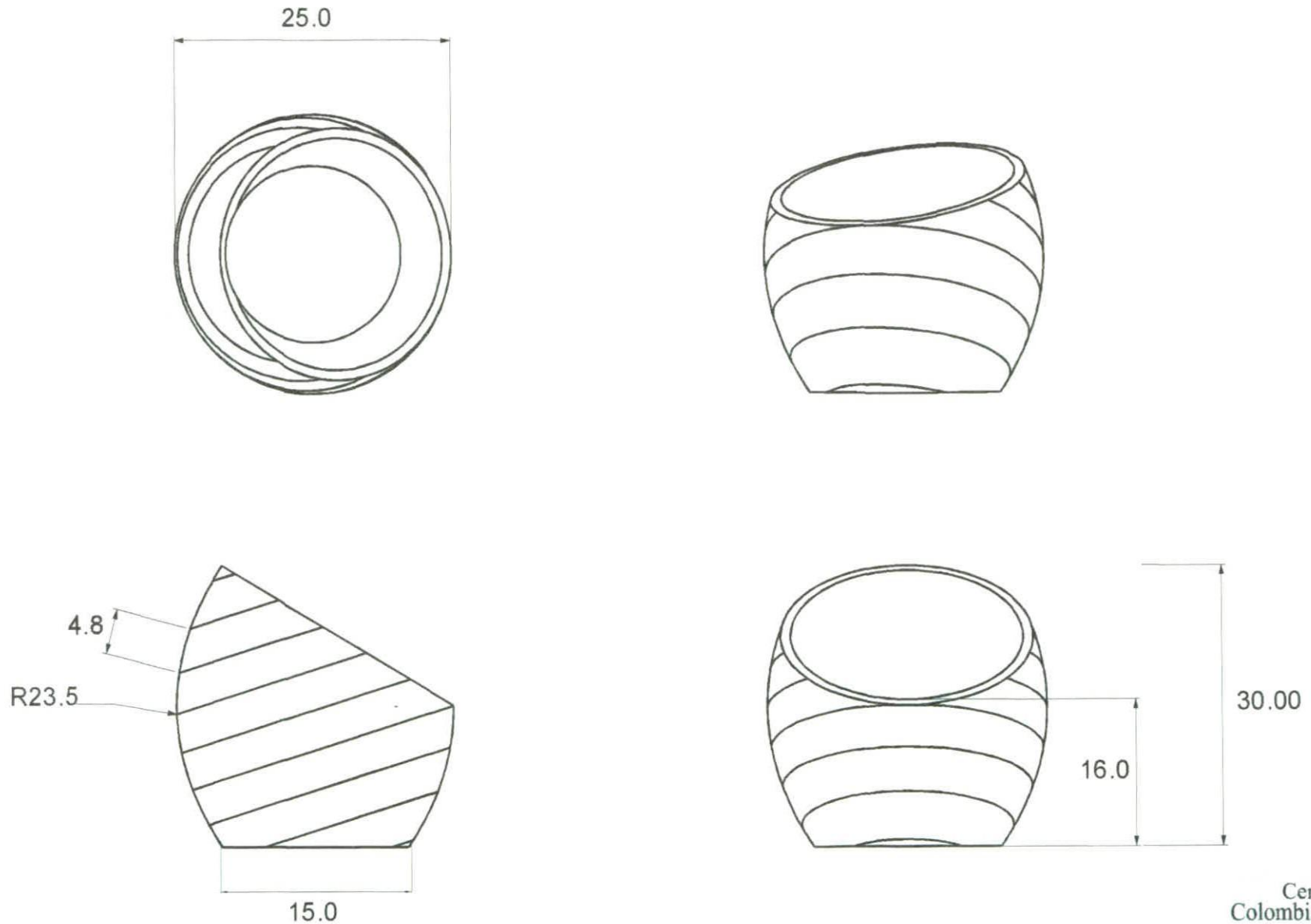



Ministerio de Comercio, Industria y Turismo
artesañas de colombia s.a.

Proyecto Comercial entre Artesanías de Colombia y Juan Carlos Arcila



Responsable: Alvaro Ivan Caro Niño y Jaime Eduardo Laverde

Centro
Colombiano *de dis.*
para la artesanía y las P.
Subgerencia de De

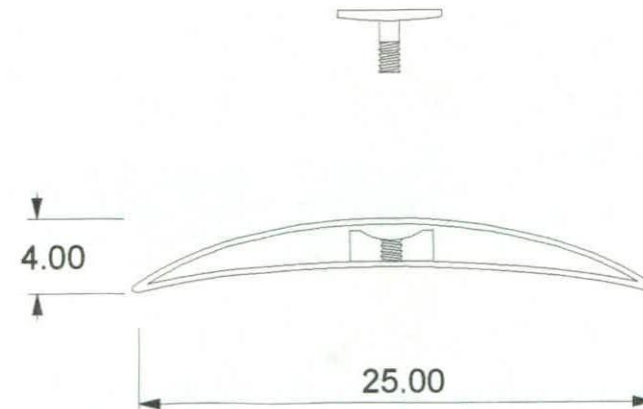
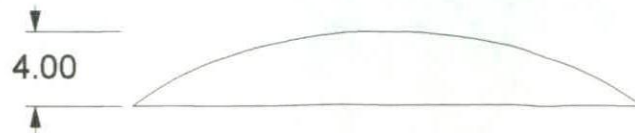
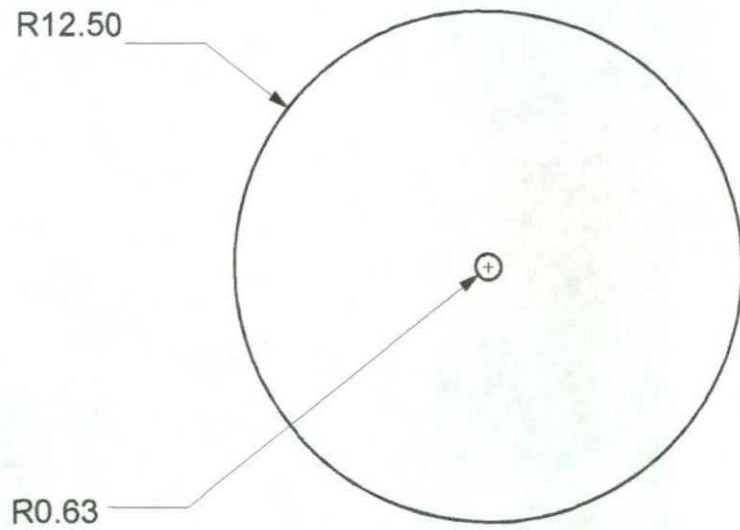

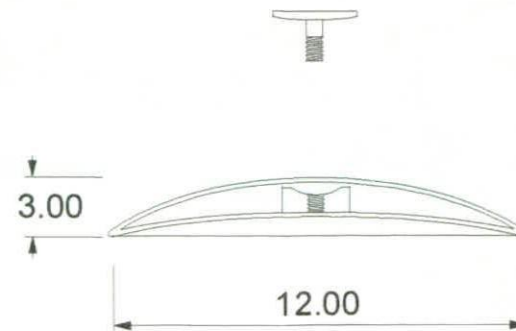
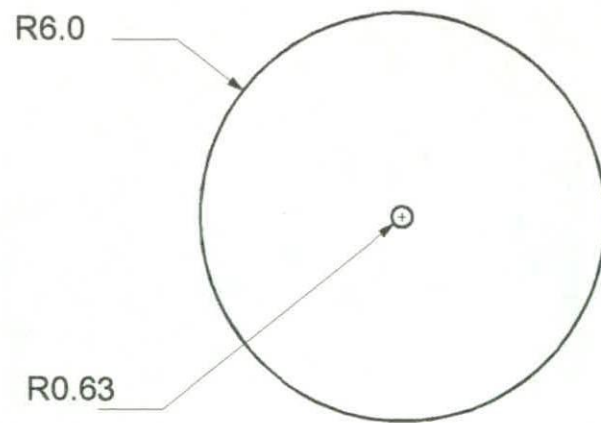



Ministerio de Comercio, Industria y Turismo
artesañas de colombia s.a.

Proyecto Comercial entre Artesanías de Colombia y Juan Carlos Arcila

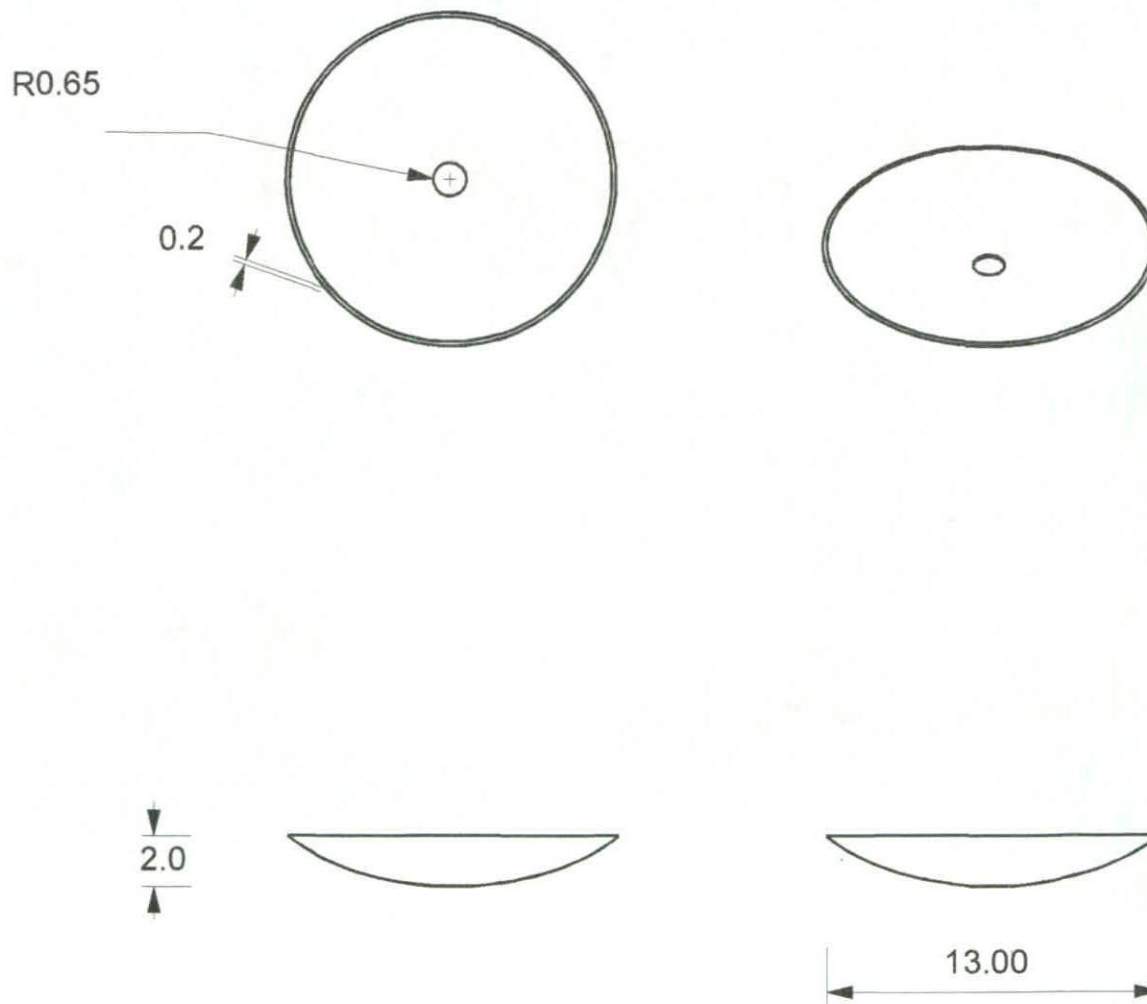

R0.65

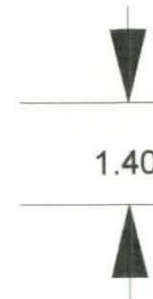
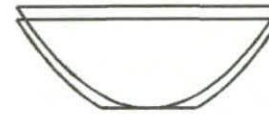
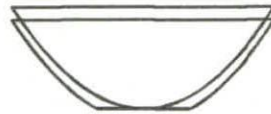
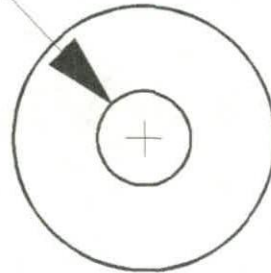

1.40



3.7



Ministerio de Comercio, Industria y Turismo
artesanías de colombia s.a.

Proyecto Comercial entre Artesanías de Colombia y Juan Carlos Arcila



Responsable: Alvaro Ivan Caro Niño y Jaime Eduardo Laverde

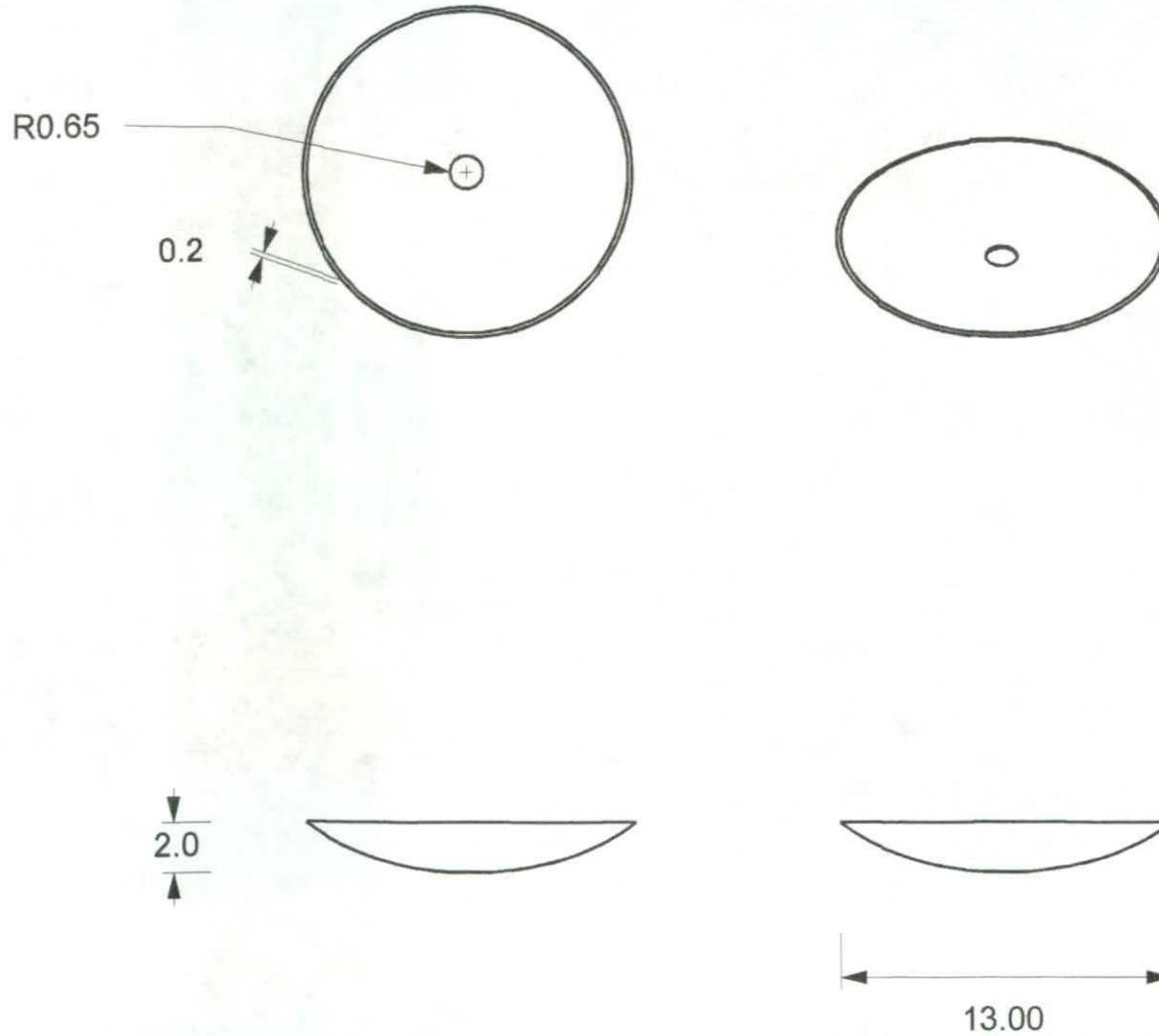

R0.65

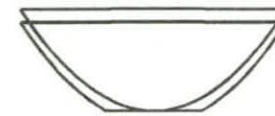
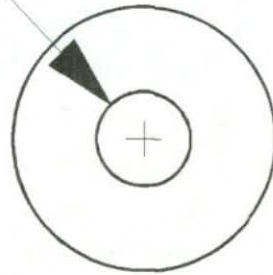

1.40

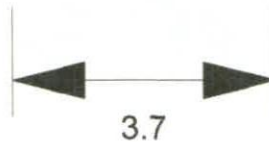

3.7

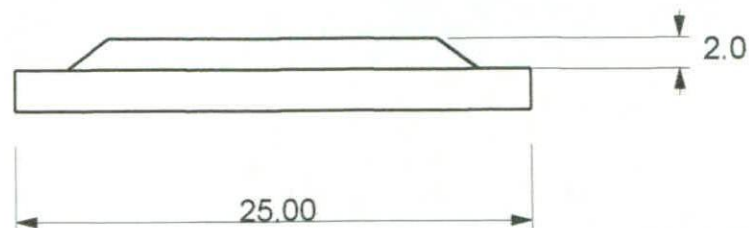
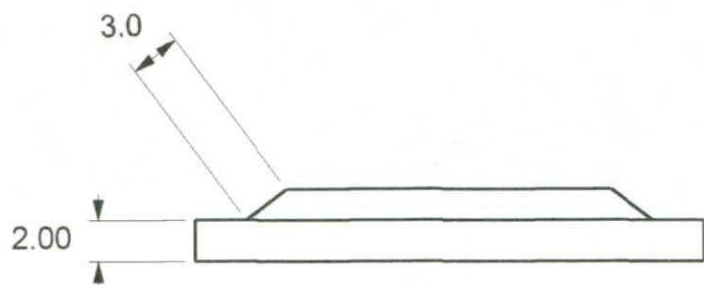
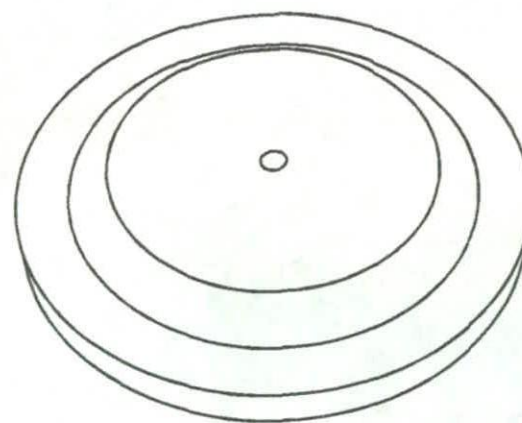
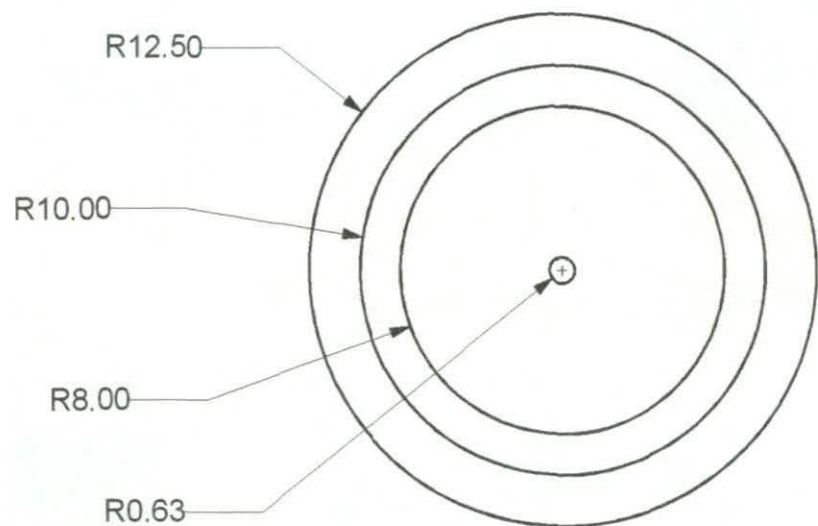



Ministerio de Comercio, Industria y Turismo
artesañas de colombia s.a.

Proyecto Comercial entre Artesanías de Colombia y Juan Carlos Arcila

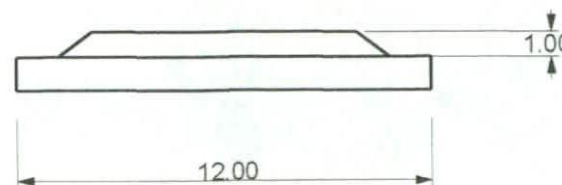
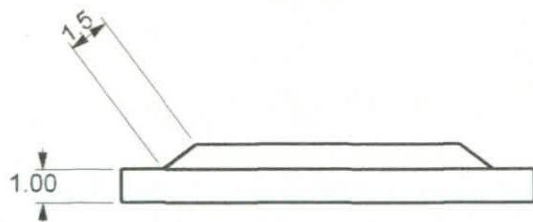
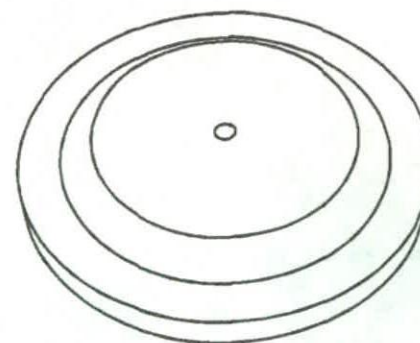
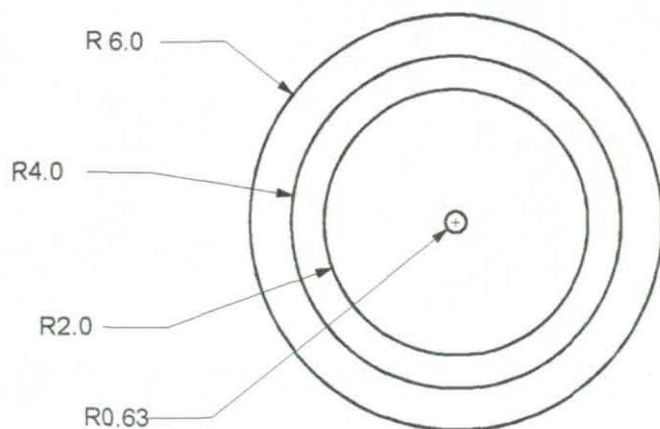



Ministerio de Comercio, Industria y Turismo
artesañas de colombia s.a.

Proyecto Comercial entre Artesanías de Colombia y
Juan Carlos Arcila

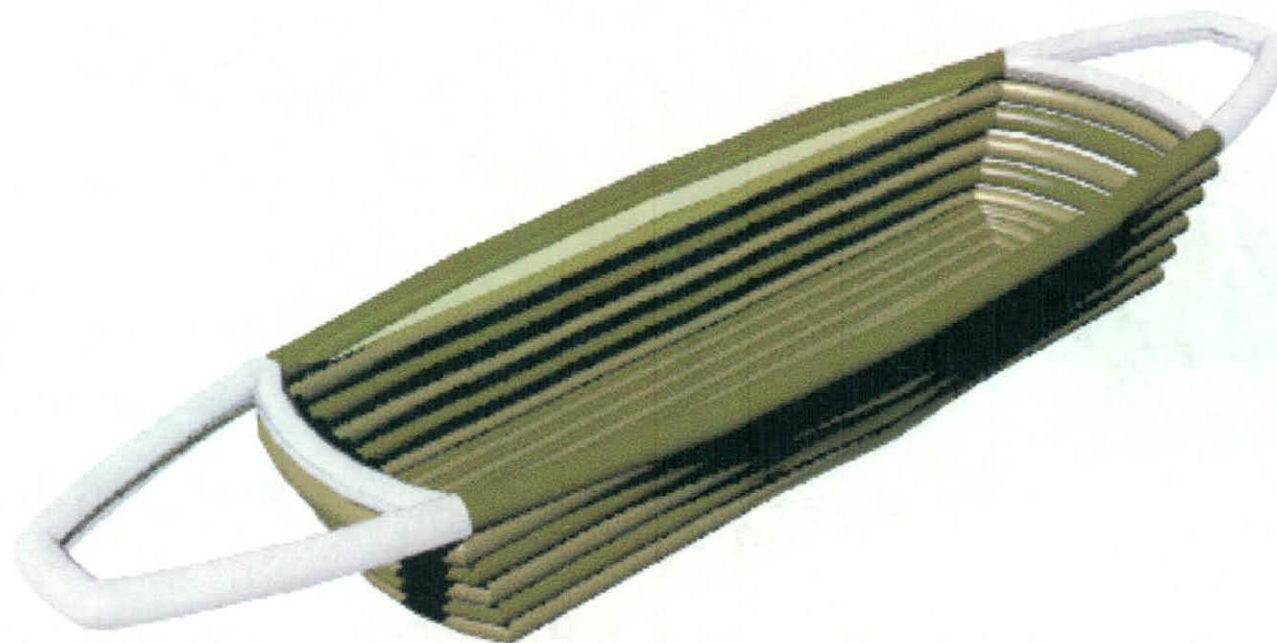

Responsable: Alvaro Ivan Caro Niño y Jaime Eduardo Laverde

Centro
Colombiano *de dis.*
para la artesanía y las P
Subgerencia de De

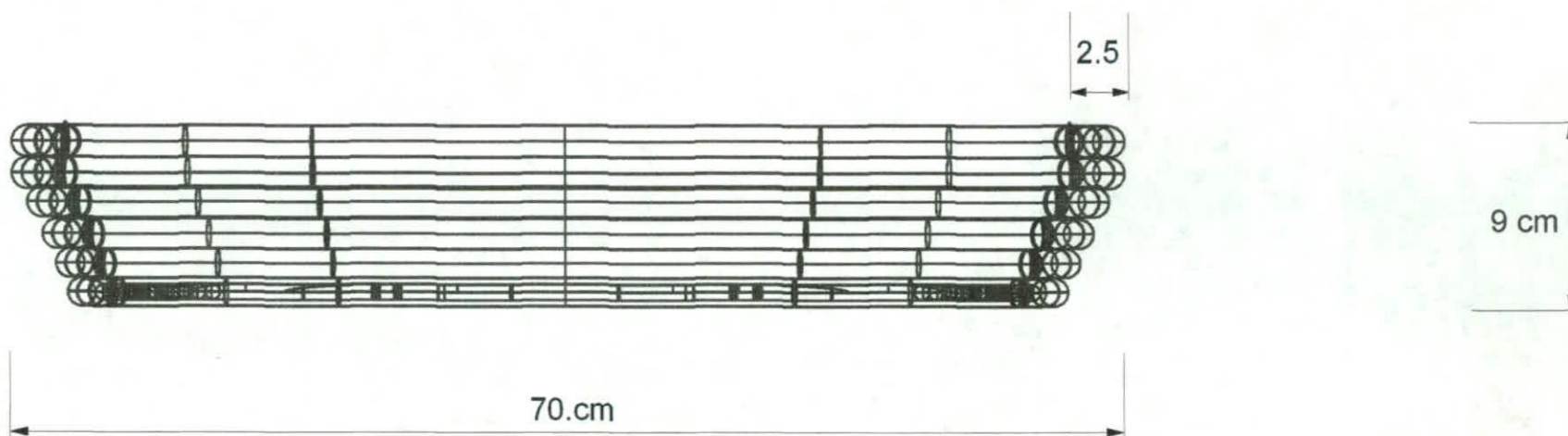



Ministerio de Comercio, Industrias y Turismo
artesañas de colombia s.a.

Proyecto Comercial entre Artesanías de Colombia y Juan Carlos Arcila

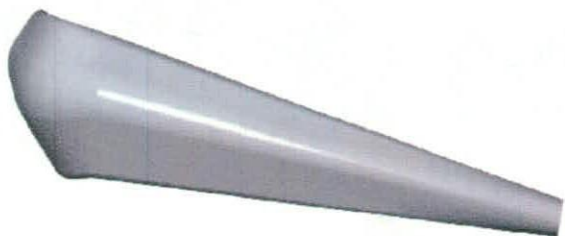



Proyecto Comercial entre Artesanías de Colombia y Juan Carlos Arcila

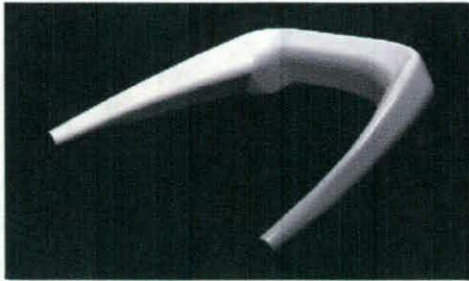

Responsable: Alvaro Ivan Caro Niño y Jaime Eduardo Laverde

Centro
Colombiano *de diseño*
para la artesanía y las PYMES
Subgerencia de Desarrollo



Proyecto entre Artesanías de Colombia y Juan Carlos Arcila Duque

Cotización de Productos

Línea	Producto	Material	Proveedor	Costo	Capacidad Produccion / Mes	Gran Total aproximado por unidad+ 20%	Entrega
Centro Balsa	Centro de mesa Diseño Balsa	Alpaca	Jose Castañeda	\$200.000 y \$250000	20 a 30		10 días
		Plata		\$600.000 y \$700.000	50		10 días
		Fique	Hugo Pinzón	\$80.000 y \$110.000	15 a20	\$360.000 a \$400.000	10 días
Candelabros	Candelabro 160 cms.	Tagua	Carlos Forero	\$320.000	1000 Unidades	\$670.000 a \$770.000	15 días
		Tagua	Super Botòn	\$250.000	5000		10 días
	Candelabro 140 cms.	Tagua	Carlos Forero	\$300.000	1000	\$620.000 a \$720.000	15 días
		Tagua	Super Botòn	\$200.000	5000		11 días
	Candelabro 120 cms.	Tagua	Carlos Forero	\$ 240.000	1000	\$570.000 a \$670.000	15 días
		Tagua	Super Botòn	\$160.000	5000		12 días
	Candelabro 40 cms.	Tagua	Carlos Forero	\$120.000	1000	\$ 370.000	15 días
		Tagua	Super Botòn	\$40.000	5000		13 días
	Candelabro 20 cms.	Tagua	Carlos Forero	\$ 60.000	1000	\$ 320.000	15 días
		Tagua	Super Botòn	\$ 30.000	5000		14 días
Candelabros Base y Soporte Redondo		Plata	Jose Castañeda	\$2.000.000			
		Alpaca	Jose Castañeda	\$400.000	20		15 Días
Bolws	Bases Redondas para Bowls	Plata	Jose Castañeda	\$250.000 y \$300.000	50		3 días
		Alpaca	Jose Castañeda	\$50.000 y \$60.000	50		3 días
Bolws esfericos	Centro de mesa diseño media esfera	Plata Martillada					
	Centro de mesa diseño media esfera	Fique	Hugo Pinzón	\$50.000 y \$70.000	15 a 20	\$ 160.000	10 días
Bolws ortogonales	Centro de Mesa diseño ortogonal	Fique	Hugo Pinzón	\$60.000 y \$80.000	15 a 20	\$ 180.000	10 días
	Centro de Mesa diseño ortogonal	Plata Martillada					
Jarrones Urnas	Jarron boca recta alto	Mopa - mopa	German Obando	\$120.000 a \$150.000	2	\$ 180.000	20 días
	Jarron boca recta bajo	Mopa - mopa	German Obando	\$100.000 a \$120.000	2	\$ 144.000	20 días
	Jarron boca inclinada alto	Mopa - mopa	German Obando	\$120.000 a \$150.000	2	\$ 180.000	20 días
	Jarron boca inclinada bajo	Mopa - mopa	German Obando	\$80.000 a \$100.000	2	\$ 120.000	20 días



Ministerio de Comercio, Industria y Turismo
artesanas de colombia s.a.

Proyecto entre Artesanías de Colombia y Juan Carlos Arcila Duque

Cotización de Productos

Proveedor	Teléfono	Producto	Material	Costo	Capacidad de Producción / Mes	Tiempo de Entrega
Jose Castañeda	091-2462069	Centro de mesa Diseño Balsa	Alpaca	\$200.000 y \$250.000	20 a 30	10 días
			Plata	\$600.000 y \$700.000	50	10 días
		Bases Redondas para Bowls	Plata	\$250.000 y \$300.000	50	3 días
			Alpaca	\$50.000 y \$60.000	50	3 días
		Candelabros Base y Soprite Redondos	Plata	\$2.000.000		
			Alpaca	\$400.000	20	15 Días
				Centro de mesa diseño media esfera	Plata Martillada	
		Centro de Mesa diseño ortogonal	Alpaca Martillada			
Hugo Pinzón	091-6101491	Centro de mesa Diseño Balsa	Fique	\$80.000 y \$110.000	15 a 20	10 días
		Centro de mesa diseño media esfera	Fique	\$50.000 y \$70.000	15 a 20	10 días
		Centro de Mesa diseño ortogonal	Fique	\$60.000 y \$80.000	15 a 20	10 días
Carlos Forero	091-4420526	Taguas para candelabro de 160cm	Tagua	\$320.000	1000	15 días
		Taguas para candelabro de 150cm	Tagua	\$300.000	1000	15 días
		Taguas para candelabro de 80cm	Tagua	\$160.000	1000	15 días
		Taguas para candelabro de 70cm	Tagua	\$140.000	1000	15 días
		Taguas para candelabro de 50cm	Tagua	\$120.000	1000	15 días
Super Botón	091-3513141	Taguas para candelabro de 160cm	Tagua	\$250.000	5000	10 días
		Taguas para candelabro de 150cm	Tagua	\$200.000	5000	11 días
		Taguas para candelabro de 80cm	Tagua	\$60.000	5000	12 días
		Taguas para candelabro de 70cm	Tagua	\$50.000	5000	13 días
		Taguas para candelabro de 50cm	Tagua	\$40.000	5000	14 días
German Obando	092- 7219889	Jarrón de Mopa Mopa recto alto	Mopa Mopa	\$120.000 a \$150.000	2	20 días
		Jarrón de Mopa Mopa recto bajo	Mopa Mopa	\$100.000 a \$120.000	2	20 días
		Jarrón de Mopa Mopa alto inclinado	Mopa Mopa	\$120.000 a \$150.000	2	20 días
		Jarrón de Mopa Mopa bajo inclinado	Mopa Mopa	\$80.000 a \$100.000	2	20 dhole richardias



Ministerio de Comercio, Industria y Turismo
artesanías de colombia s.a.

Proyecto entre Artesanías de Colombia y Juan Carlos Arcila Duque

Cotización de Productos

Proveedor	Teléfono	Producto	Material	Costo	Capacidad de Produccion / Mes	Tiempo de Entrega
Jose Castañeda	091-2462069	Centro de mesa Diseño Balsa	Alpaca y Fique	\$360.000 a \$400.000	20 a 30	10 días
Hugo Pinzón	091-8101491	Bowls Redondo	Alpaca y Fique	\$150.000 a \$200.000		
Omaira Manrique		Bowl Ortogonal	Alpaca y Fique	\$150.000 a \$210.000	50	3 días
					50	3 días
Carlos Forero	091-4420526	Candelabro de 160 de altura	Alpaca, hierro y tagua	\$670.000 a \$770.000	20	15 Días
Super Botón	091-3513141	Candelabro de 150 de altura	Alpaca, hierro y tagua	\$620.000 a \$720.000	20	15 Días
		Candelabro de 80 de altura	Alpaca, hierro y tagua	\$490.000	20	15 Días
		Candelabro de 40 de altura	Alpaca, hierro y tagua	\$370.000	20	15 Días
		Candelabro de 24 de altura	Alpaca, hierro y tagua	\$360.000	20	15 Días
Jose Castañeda	091-2462069	Centro de mesa diseño media esfera	Alpaca con textura	\$150.000 a \$200.000	5	10 días
		Centro de Mesa diseño ortogonal	Alpaca con textura	\$150.000 a \$200.000	5	10 días
German Obando	092- 7219889	Jarrón de Mopa Mopa recto alto	Mopa Mopa	\$120.000 a \$150.000	2	20 días
		Jarrón de Mopa Mopa recto bajo	Mopa Mopa	\$100.000 a \$120.000	2	20 días
		Jarrón de Mopa Mopa alto inclinado	Mopa Mopa	\$120.000 a \$150.000	2	20 días
		Jarrón de Mopa Mopa bajo inclinado	Mopa Mopa	\$80.000 a \$100.000	2	20 dhole richardias

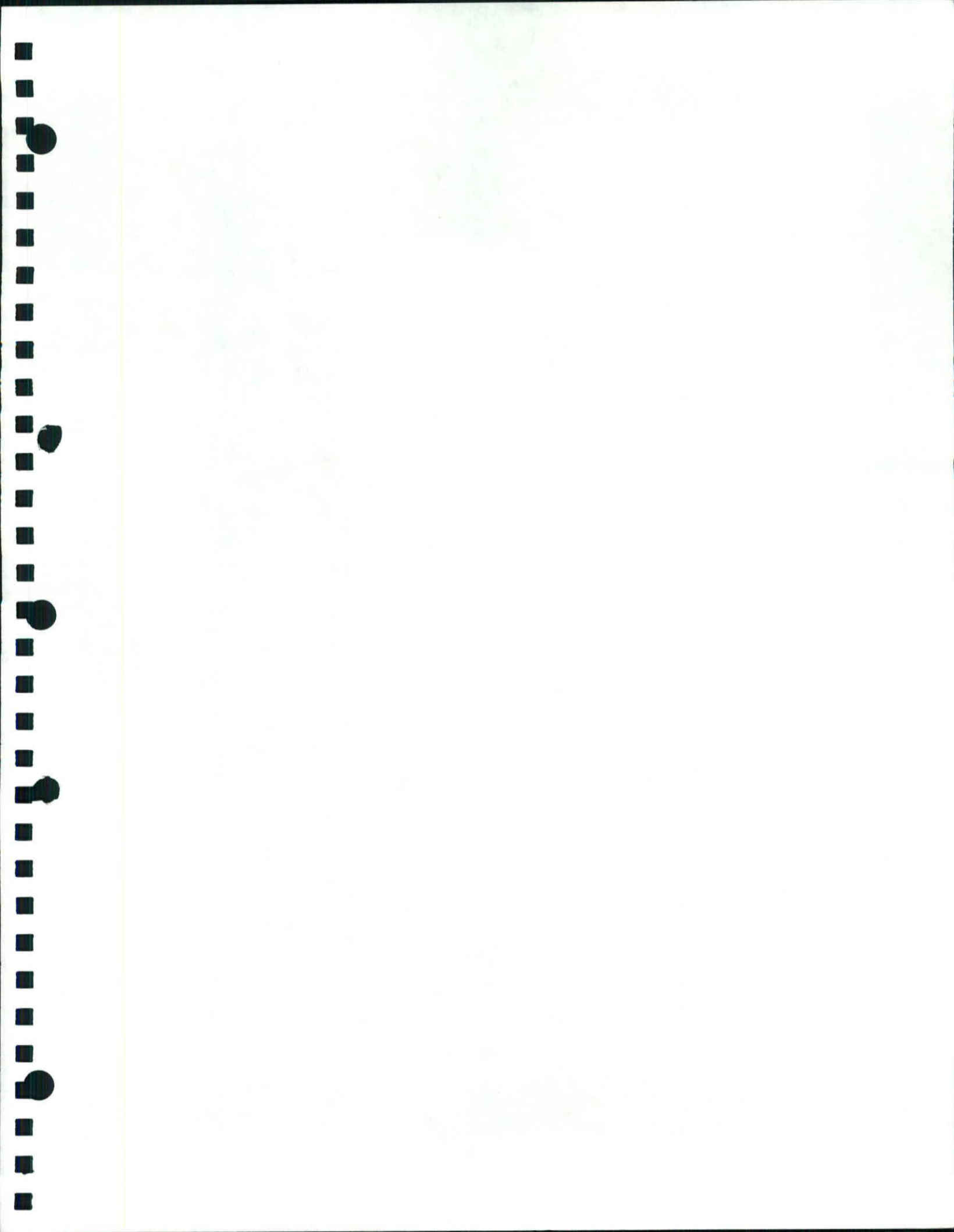

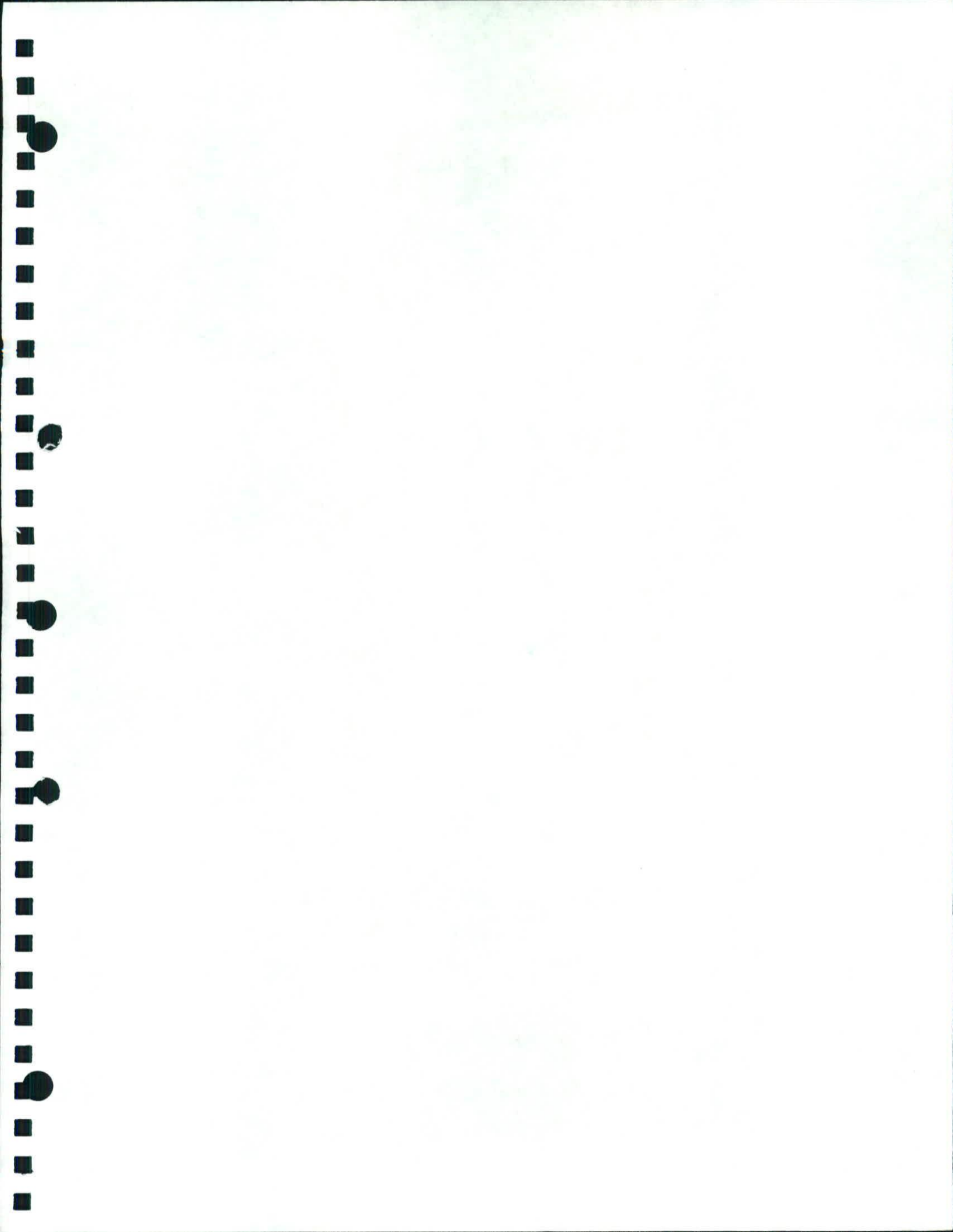



Ministerio de Comercio, Industria y Turismo
artesanías de Colombia s.a.

Proyecto Comercial entre Artesanías de Colombia y Juan Carlos Arcila - Duque

Propuestas de Diseño
Bocetos
Enero de 2005

Responsables: D.I. Alvaro Ivan Caro Niño - D.I. Jaime Eduardo Laverde

Centro *de diseño*
Colombiano
para la artesanía y las PYMES
Subgerencia de Desarrollo

W-25.



25

Flores

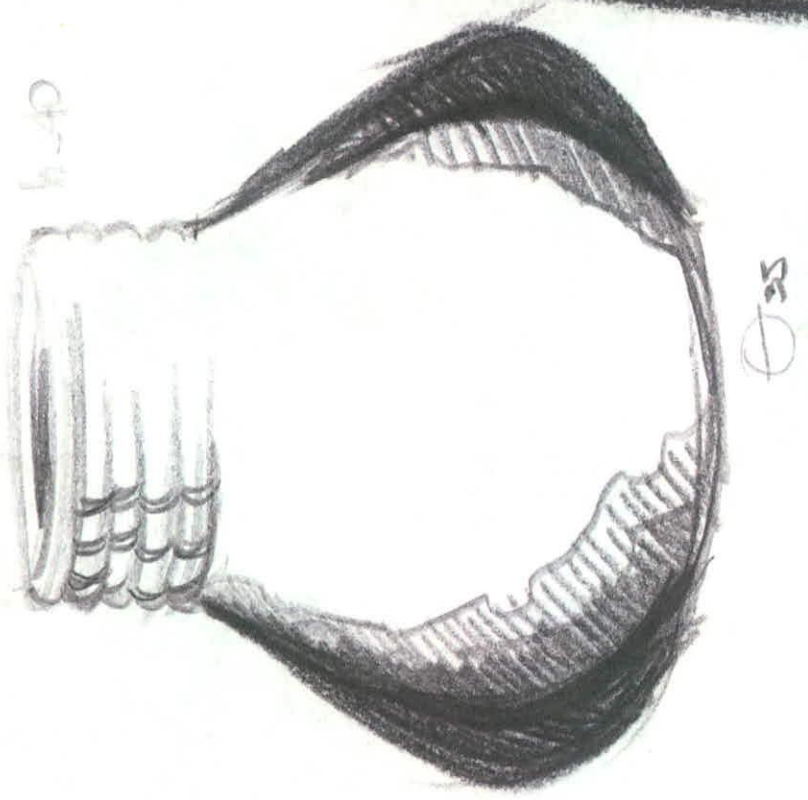
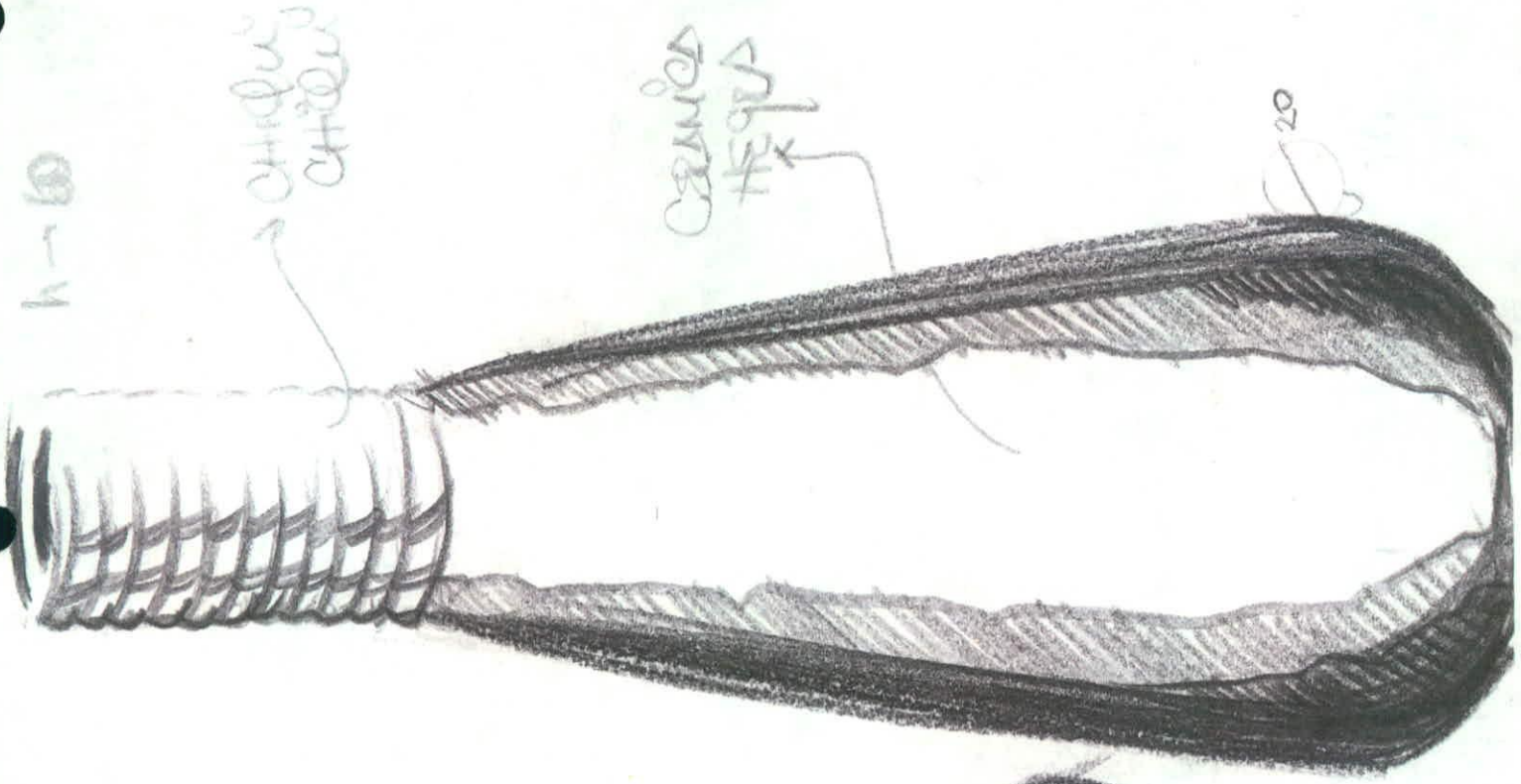

Bowls.

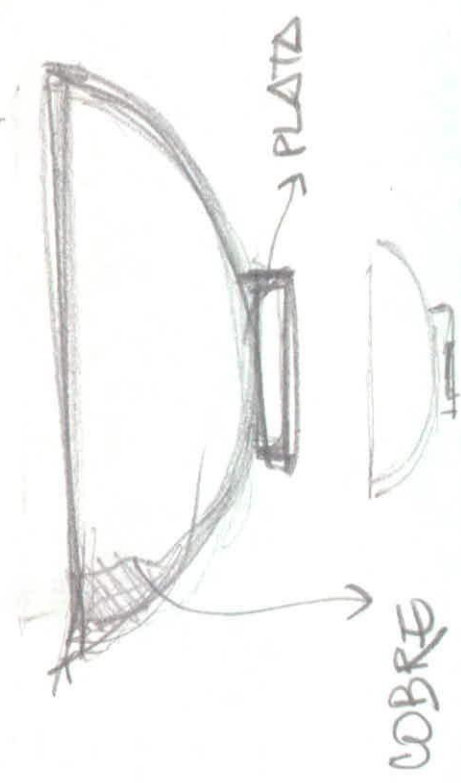
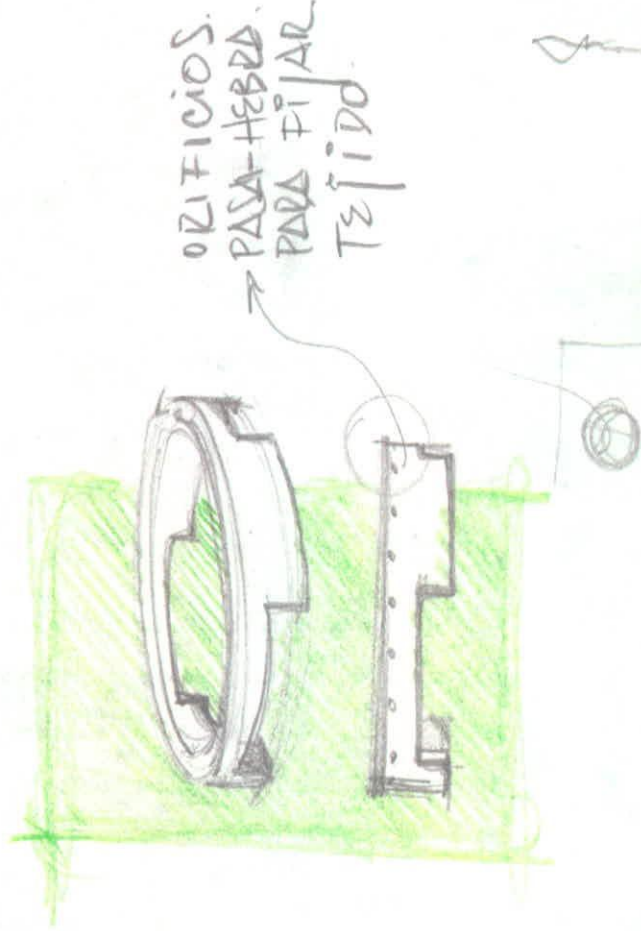
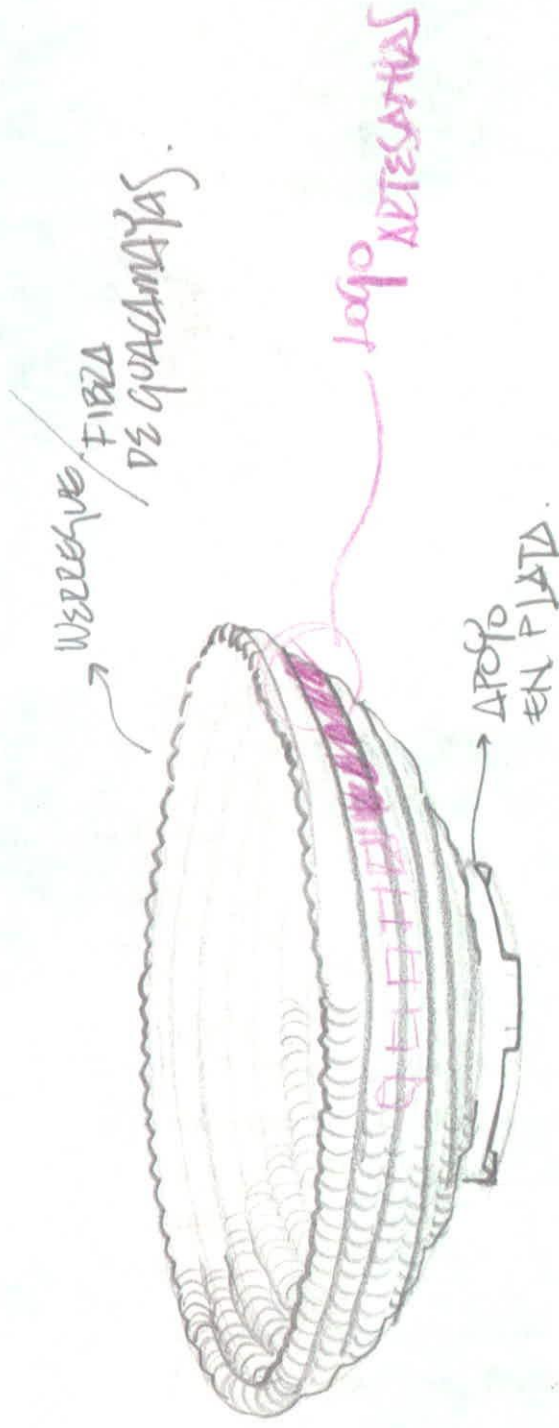

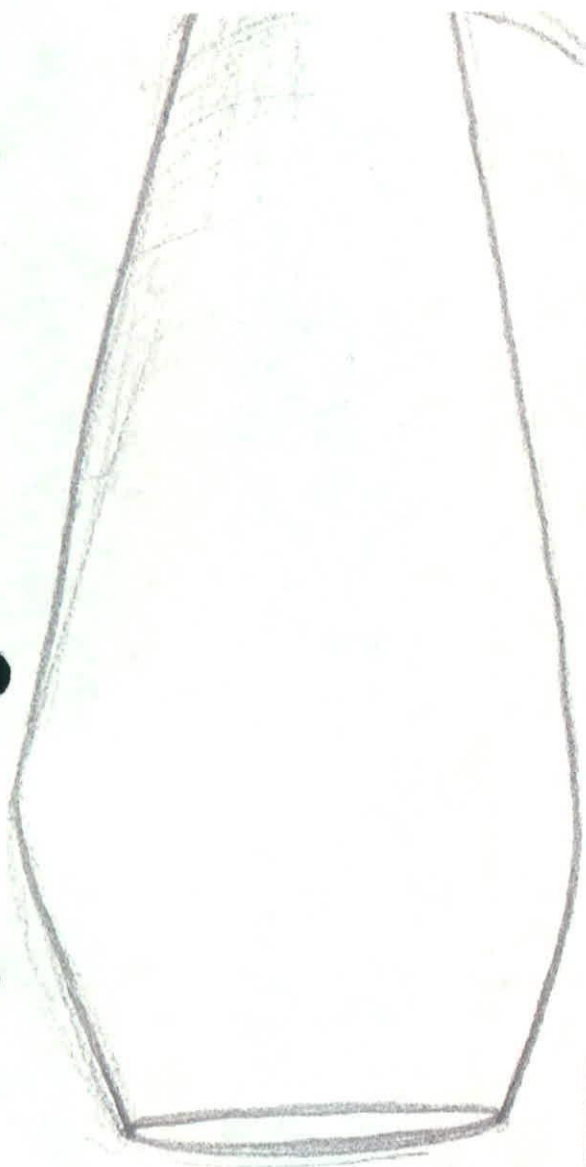

CATEDRALES.

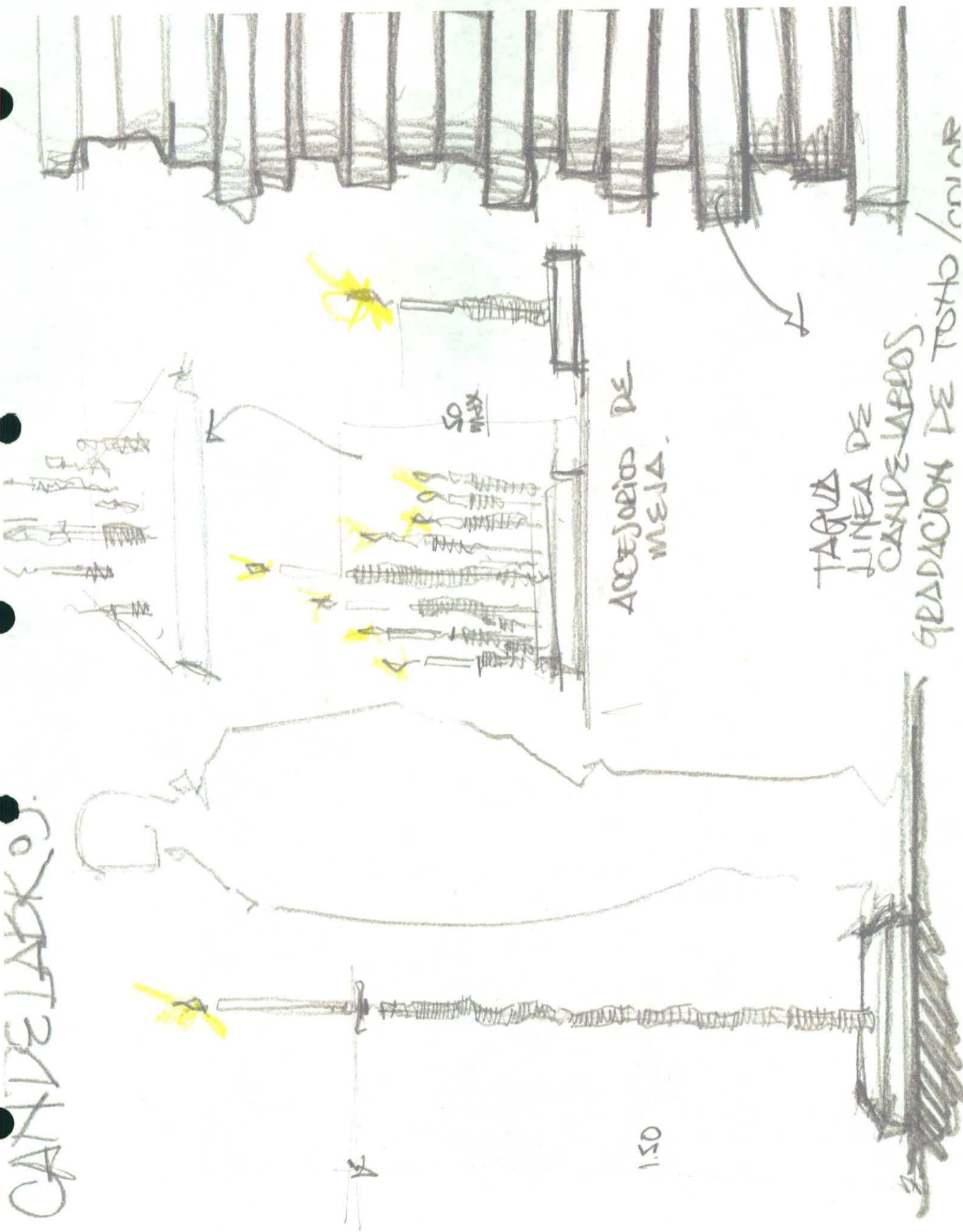

ACEJORIO DE MEJA.

TAGUA DE LINEA DE CATEDRALES.

GRADACION DE TOTO / UNAR

1.50

9 3/4

A

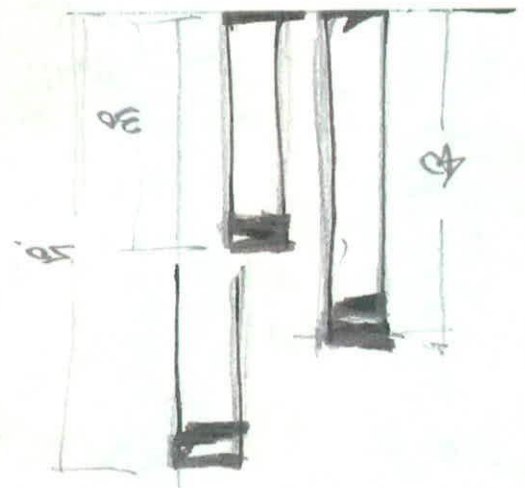

MADERA
ENSAJADA
(guarda)

¡Puedo
¡que florecer!

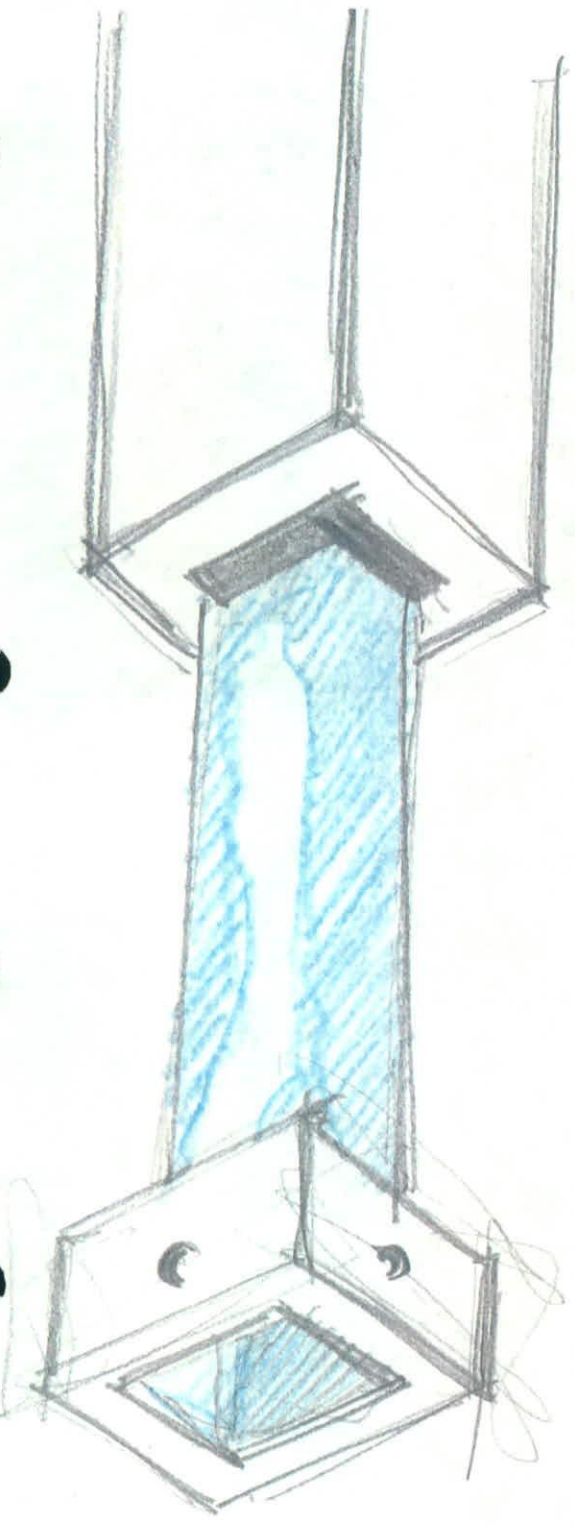
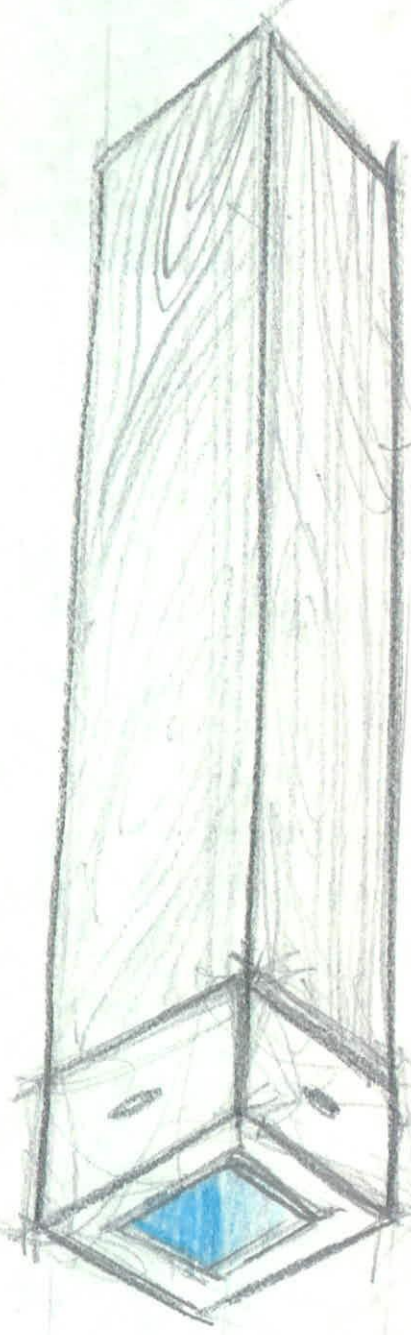

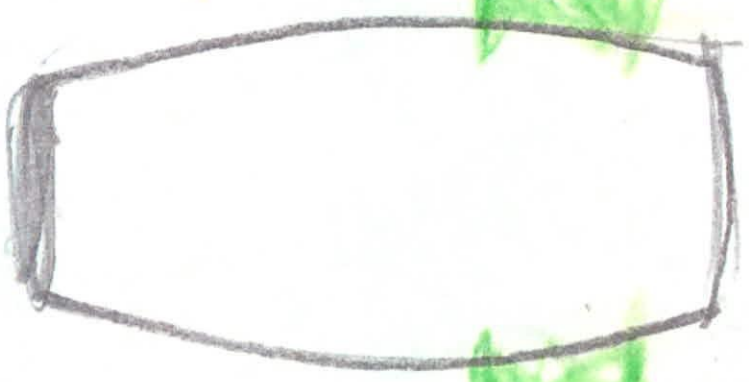
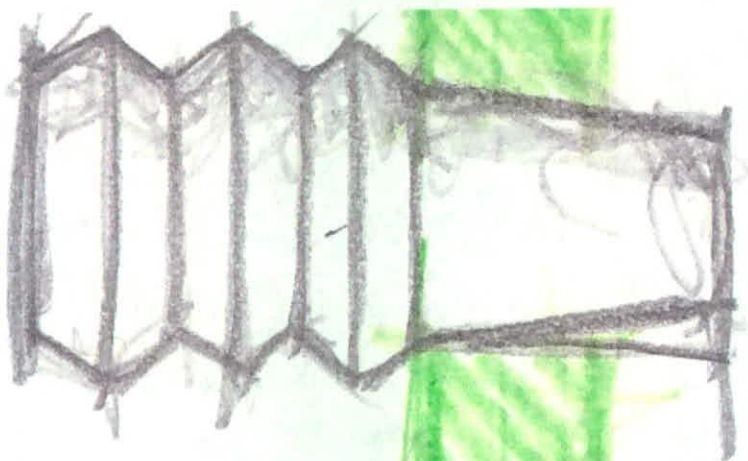

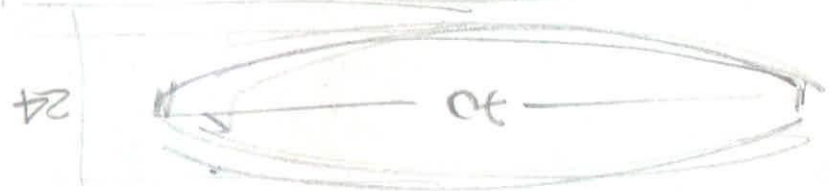
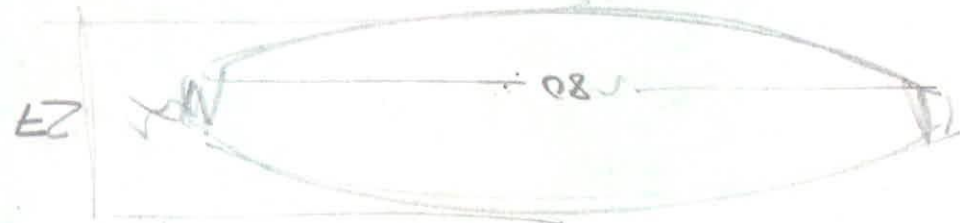
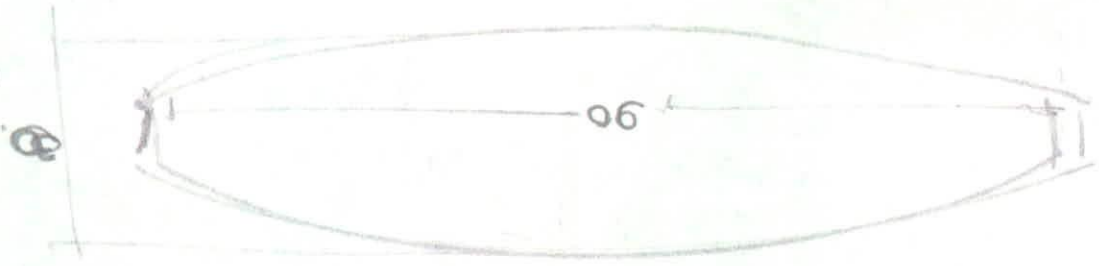

ANGUSTACION
PLATA-TEJIDO

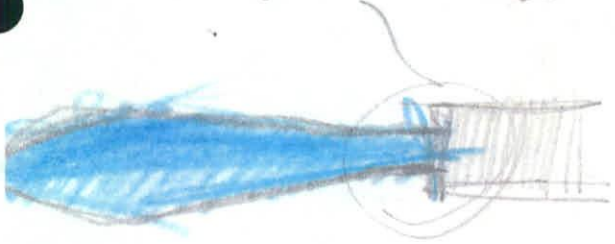

APLICES
EN PLATA

TEJIDO
GUARDAMAYAS

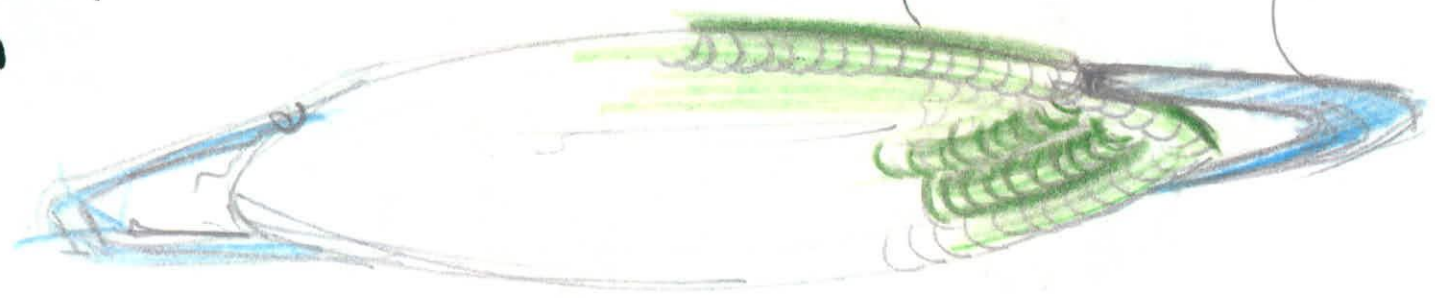

BANDERAS.

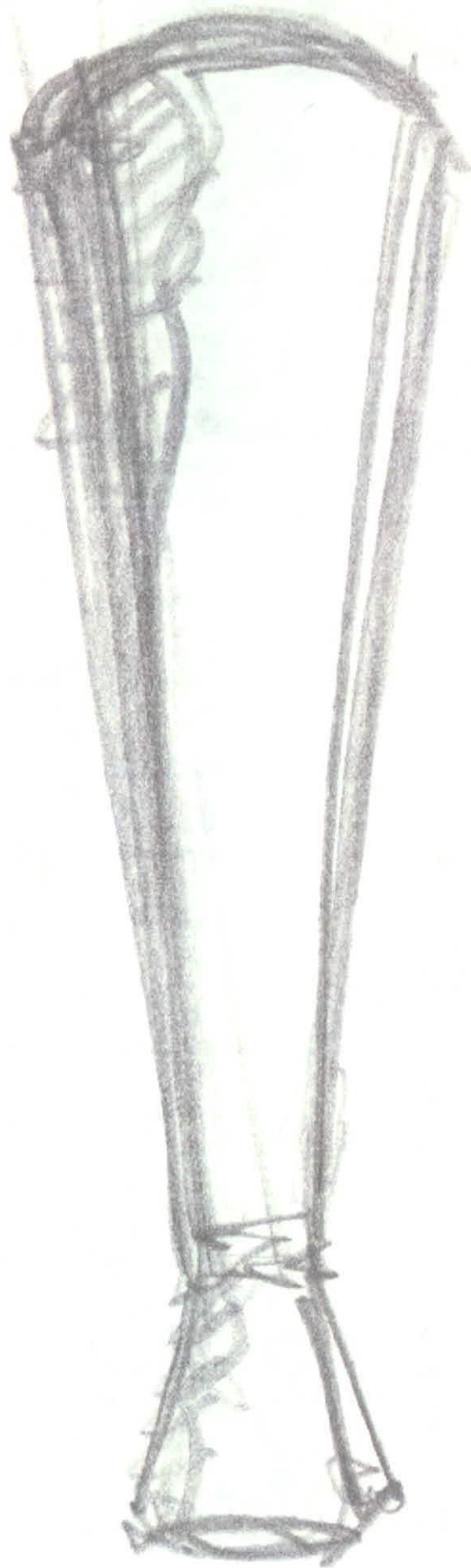

→ DISEÑO GRAFICO
INTERIOR

QUE
SUGIERE TEXTURAS

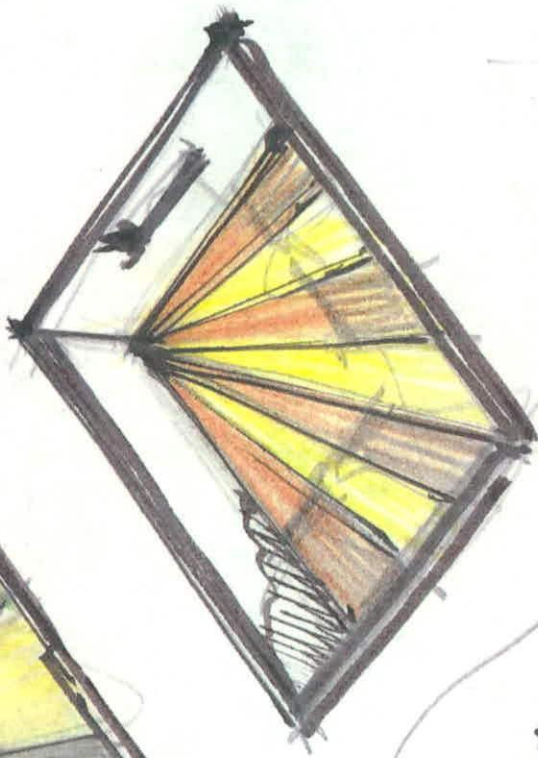

LÍNEA
BANDejas

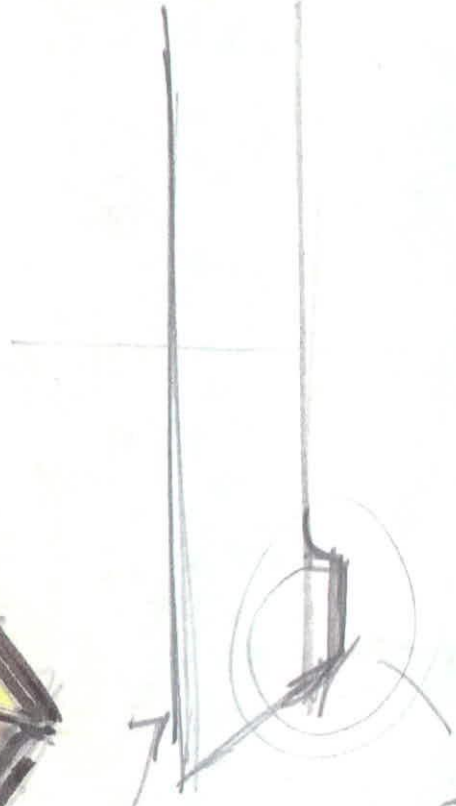
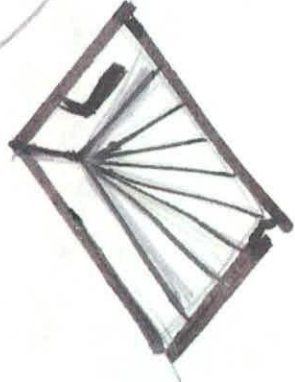

APOYO.

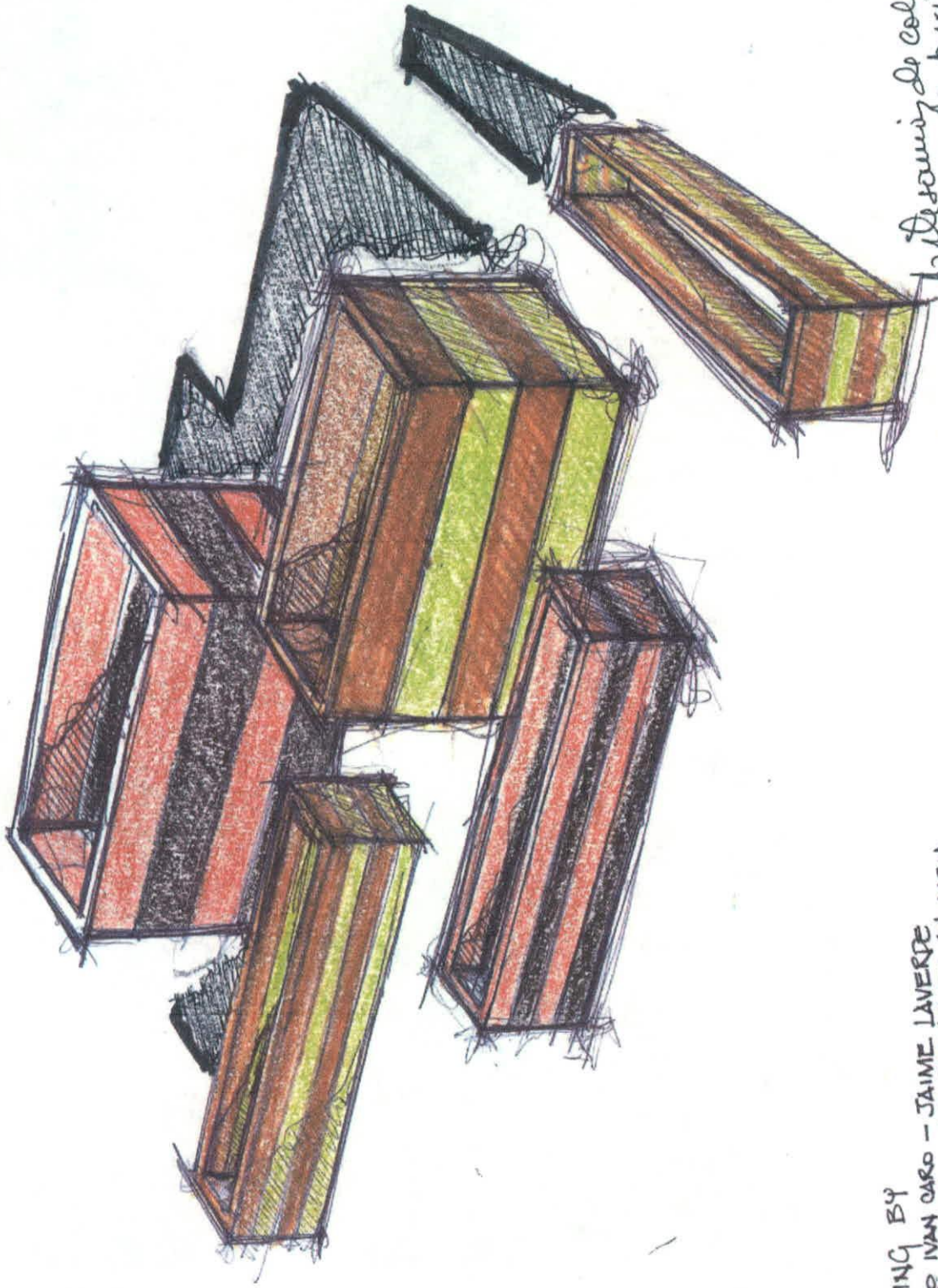

DRAWING BY
ALVARO IVAN CARO - JAIMIE LAVERDE
CENTRO DE DISEÑO - ARTESANIAS DE COLOMBIA.

No. 10 Desamunio de Colombia S.A.
Juan Carlos Buitrago

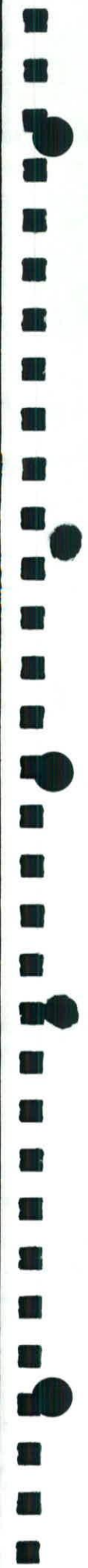

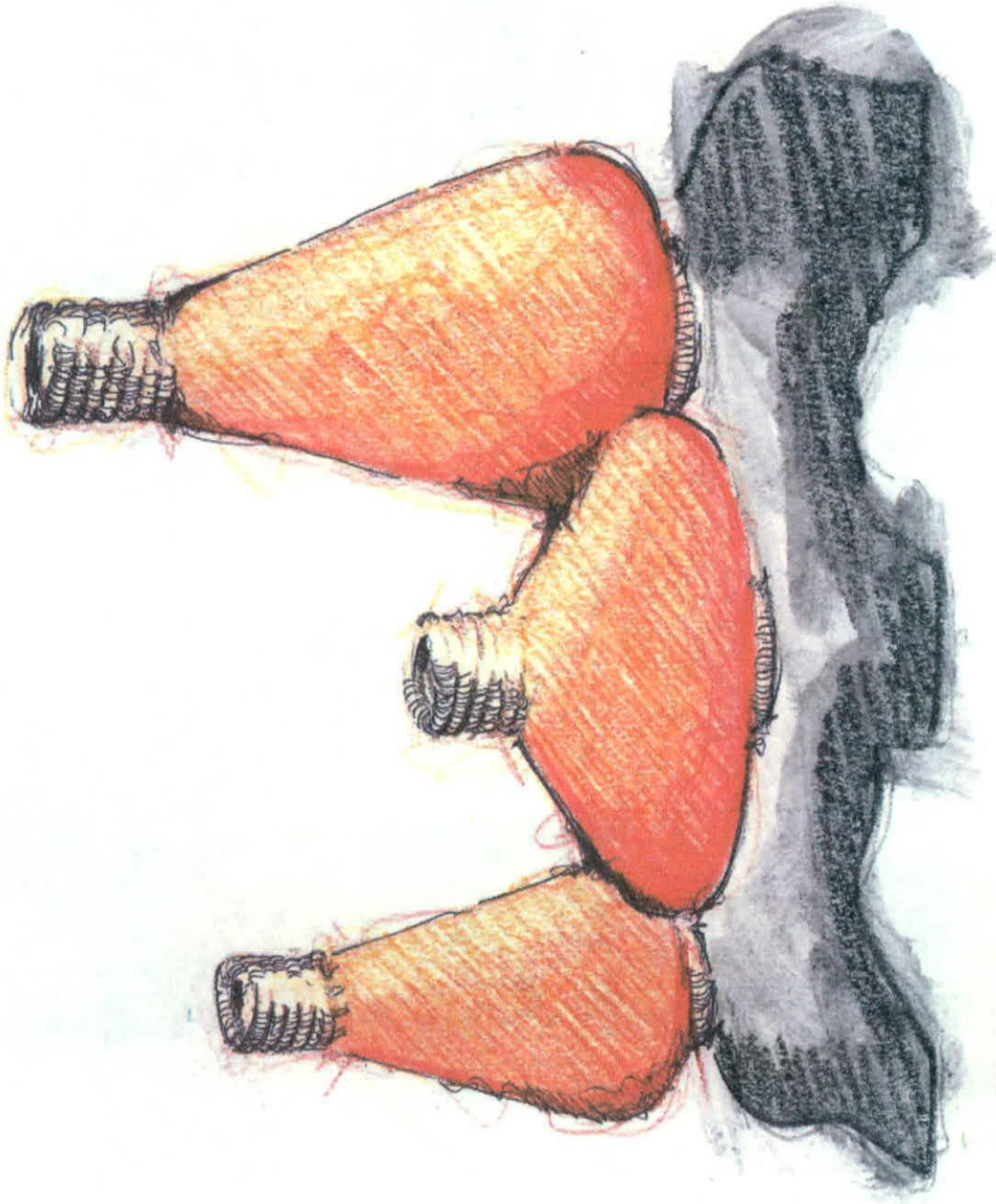

DRAWINGS BY
ALVARO IBARRA CARO - JAIMIE LAVERDE
CENTRO DE DISEÑO: ARTESANIAS DE COLOMBIA S.A.

Montesano de Colombia
Jaramo Coucho de la Duya

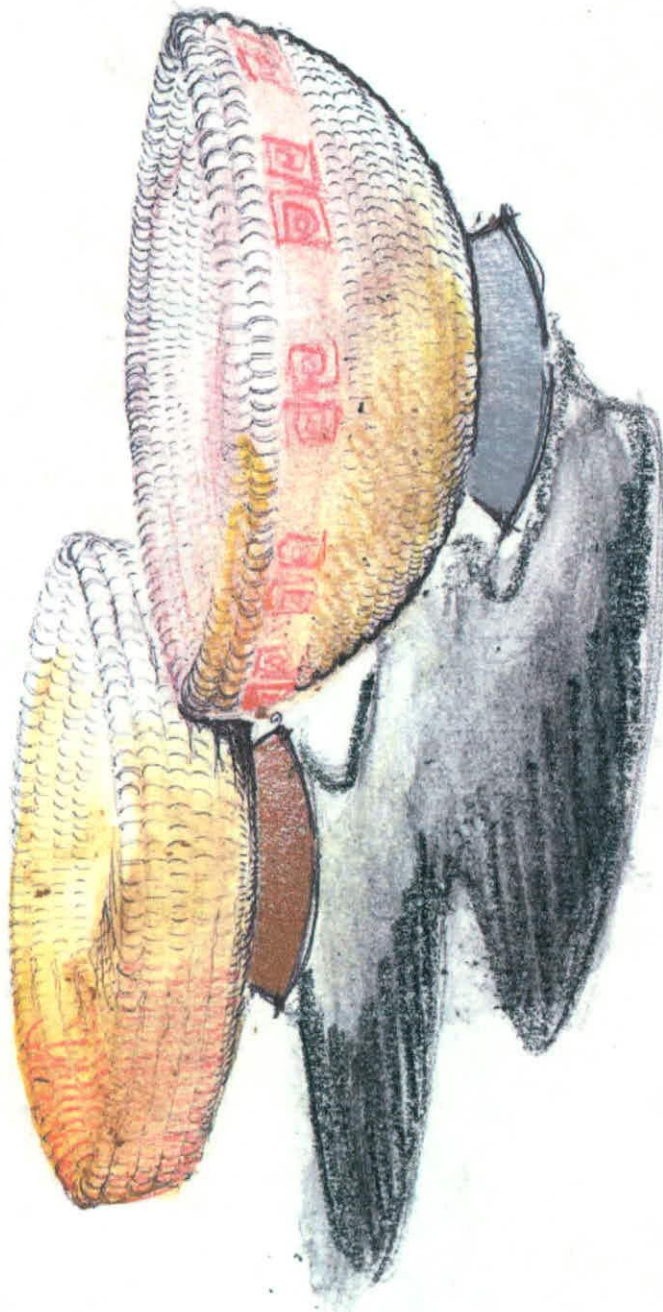

DRAWN BY JAIME LAVERDE
ALVARO IVAN CARRERA -
CENTRO DE DISEÑO - ARTESANIAS DE COLOMBIA S.A.

No. de samitas de Colombia 5.6
Juan Carlos Jover de Payue

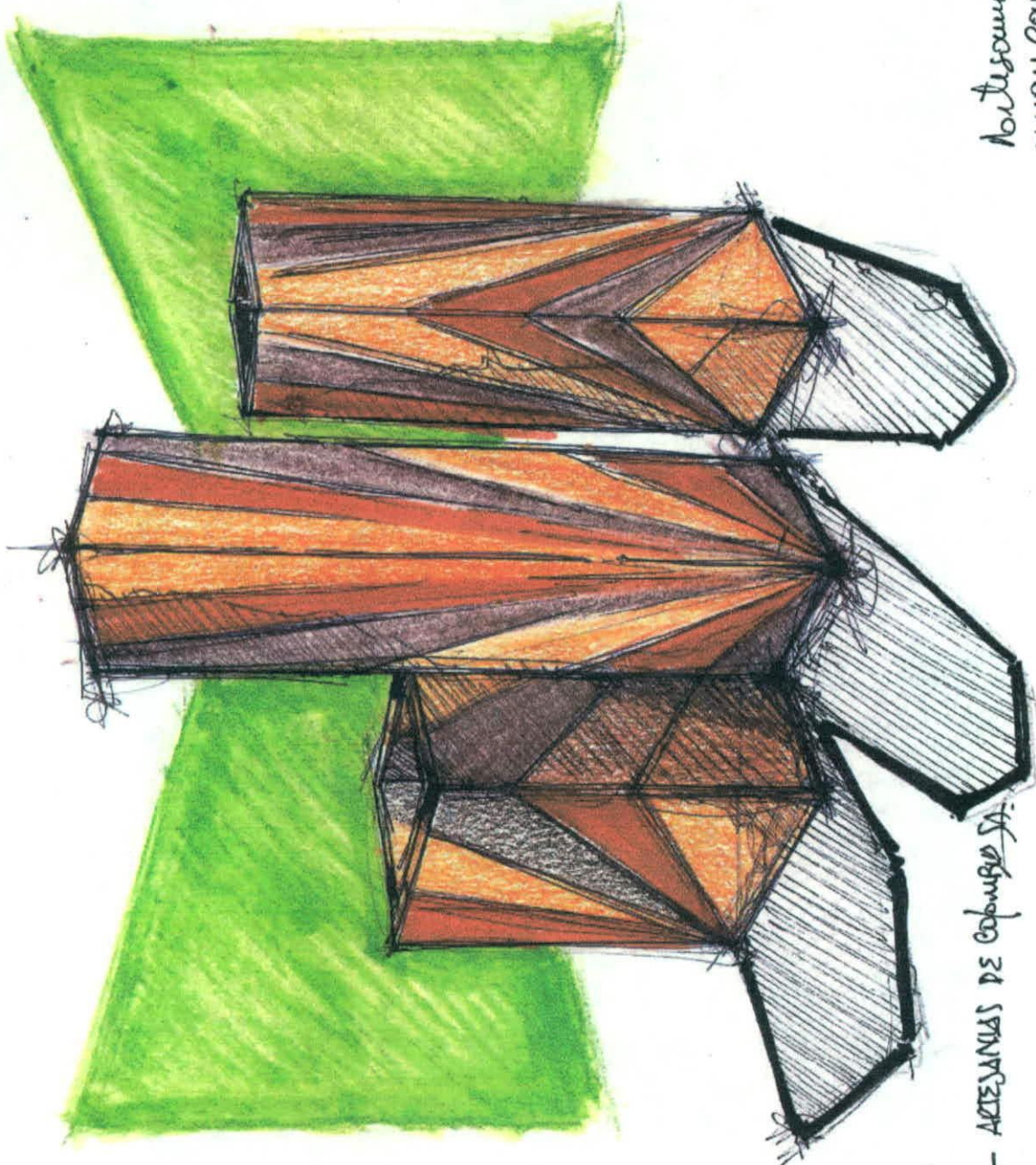

Artesanías de Colombia S.A.
Juan Carlos de la Cruz

DRAWING BY
ALVARO NAH CARD
JAIQUE LAVERDE
CENTRO DE DISEÑO - ARTESANIAS DE COLOMBIA S.A.



DRAWING BY
ALVARO MANCERO - JAIME LAVERDE.
CENTRO DE DISEÑO - ARTESANIAS DE COLOMBIA SA.

Montesanoj de Colombia S.
Juan Carlos Tori la Cruz

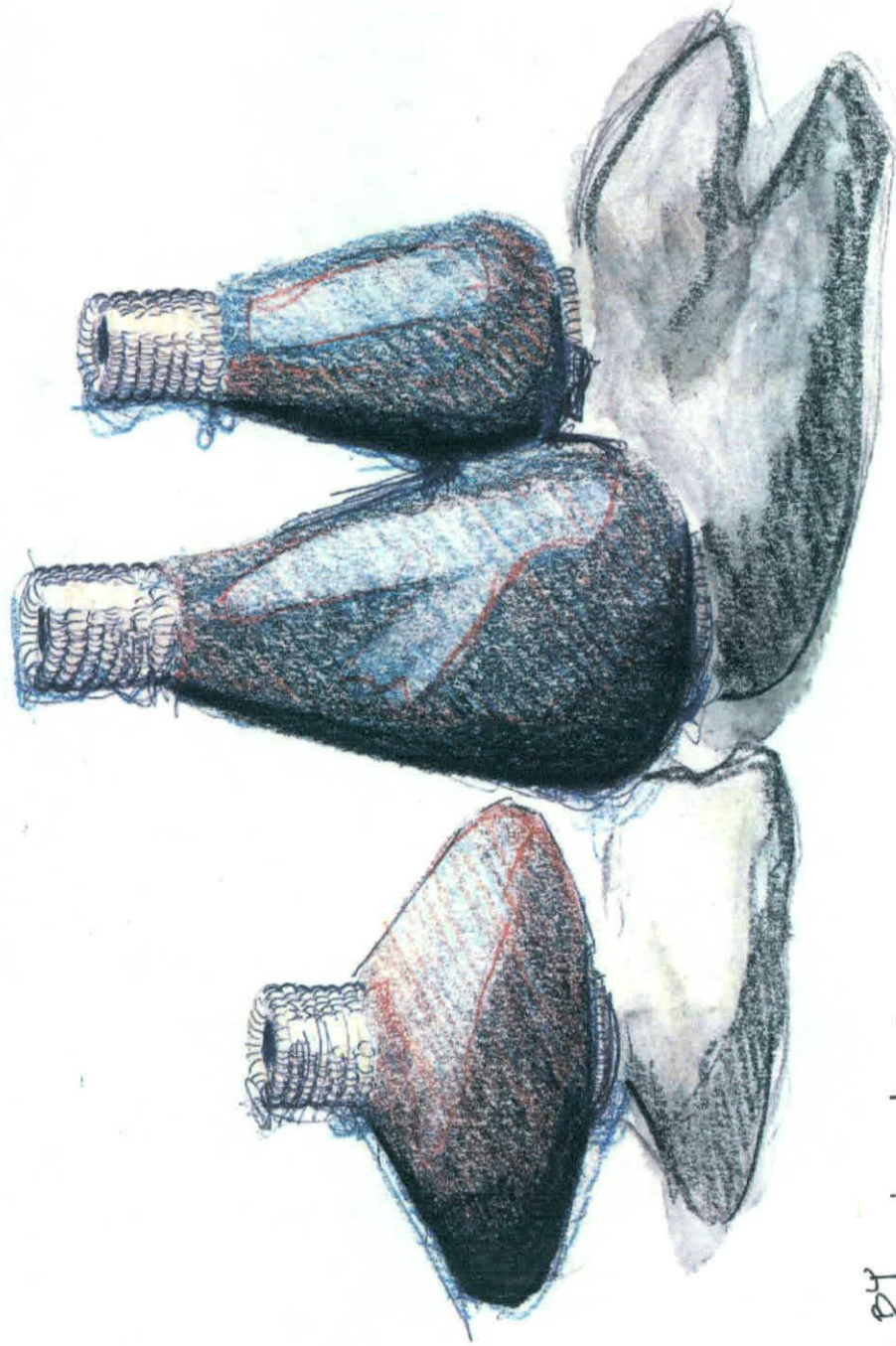

PRAWITIKI DY
ALVARO IVAN CARO - JAIME LAVERDE
CENTRO DE DISEÑO: ARTEJANIAS DE COLOMBIA S.A.

botle forming by Colombia s.a.
Juan Carlos Bonai Orduyee

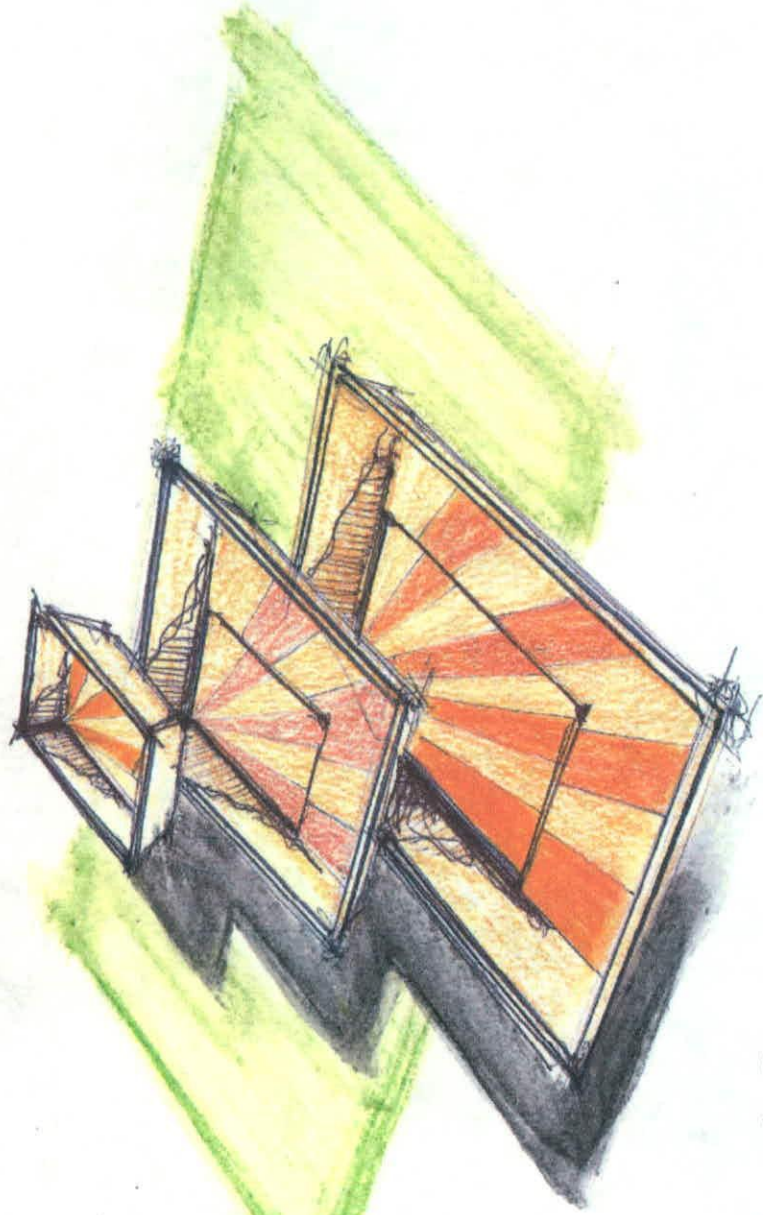

DRAWING BY
ALVARO IVAN CARRO - POME LAVERDE.
ENTRO DE DISEÑO - ARTESANIAS DE COLOMBIA S.A.

Artisanias de Colombia S.A.

