

artesanías
de colombia

Propuestas de Diseño

Departamento del Magdalena

Laboratorio de Innovación y Diseño del Magdalena

DICIEMBRE 2020

LUZÁNGELA BRITO CARRILLO



MAGDALENA

Propuestas de Diseño Lab Magdalena 2020



LABORATORIOS DE
INNOVACIÓN
Y DISEÑO



Seguimiento a proceso de elaboración
de muestras.

Calado Porta matera- Totumo

Luz Estela Torres



El progreso
es de todos

Gobierno
de Colombia
Mincomercio



artesanías de colombia



Seguimiento a proceso de elaboración
de muestras.

Calado Porta matera- Totumo

Luz Estela Torres



El progreso
es de todos

Gobierno
de Colombia
Mincomercio



artesanías de colombia



Seguimiento a proceso
de elaboración de
muestras.

Grabado – Totumo

Maria Zambrano y grupo
de artesanos totumo
Santa Bárbara



El progreso
es de todos

Gobierno
de Colombia
Mincomercio



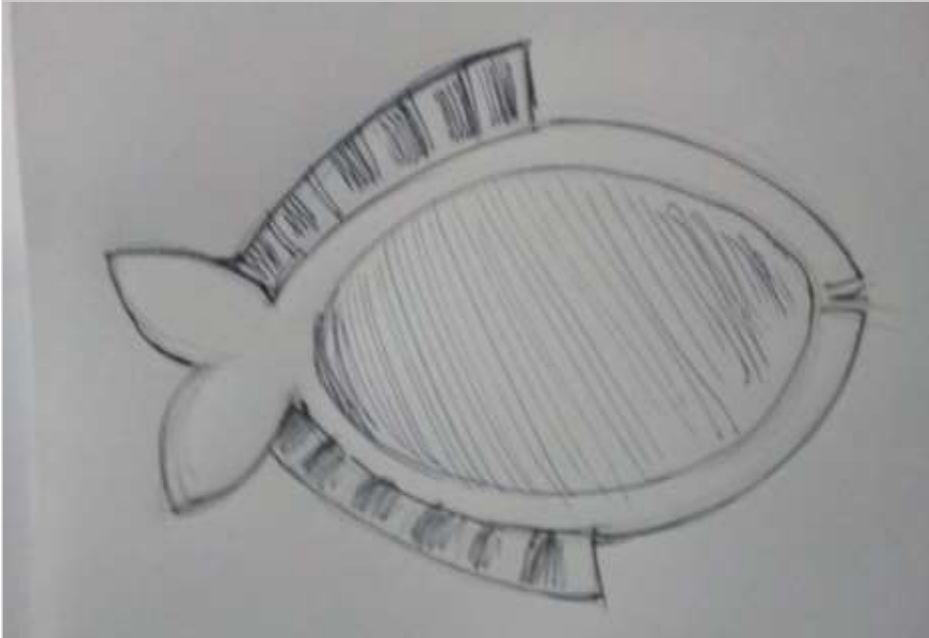

El progreso
es de todos

Gobierno
de Colombia
Mincomercio





El progreso
es de todos

Gobierno
de Colombia
Mincomercio



artesanías de colombia



Seguimiento a proceso de elaboración
de muestras.

Bowl tallado – Madera

Farid Flóres



El progreso
es de todos

Gobierno
de Colombia
Mincomercio





Seguimiento a proceso de
elaboración de muestras.

Bowl tallado – Madera

Farid Flóres



El progreso
es de todos

Gobierno
de Colombia
Mincomercio



artesanías de colombia



Seguimiento a proceso de elaboración
de muestras.

Pescador – Madera

Farid Flóres



El progreso
es de todos

Gobierno
de Colombia
Mincomercio



artesanías de colombia

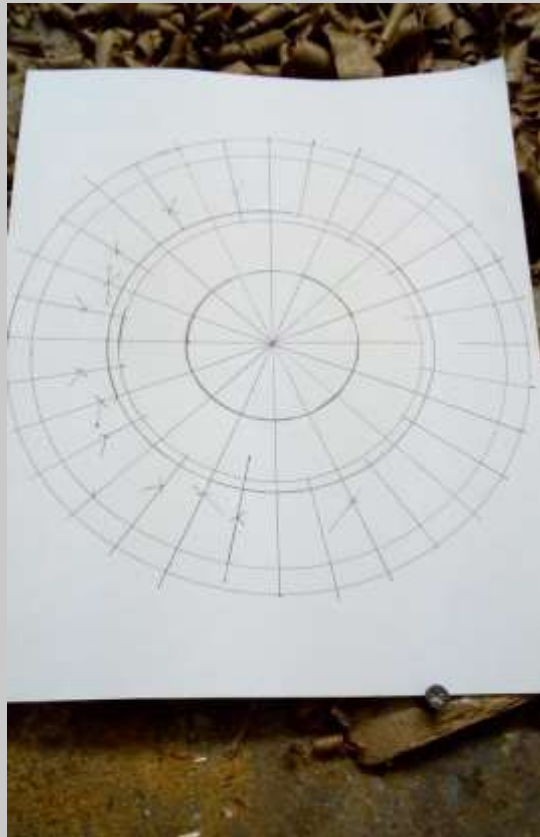

Seguimiento a proceso de elaboración de muestras.

Tabla de quesos tallada – Madera

Farid Flóres



El progreso
es de todos

Gobierno
de Colombia
Mincomercio





Seguimiento a proceso de elaboración de muestras.

Porta vasos - Piedra

Alejandro Pertuz



El progreso
es de todos

Gobierno
de Colombia
Mincomercio





Seguimiento a proceso de elaboración de muestras.

Bowl- coco

Ibeth paz y grupo de Artesanos coco SM



El progreso
es de todos

Gobierno
de Colombia
Mincomercio





Seguimiento a proceso de elaboración de muestras.

Recipientes – arcilla

Olga Garcia



El progreso
es de todos

Gobierno
de Colombia
Mincomercio



BOCETO O IDEA

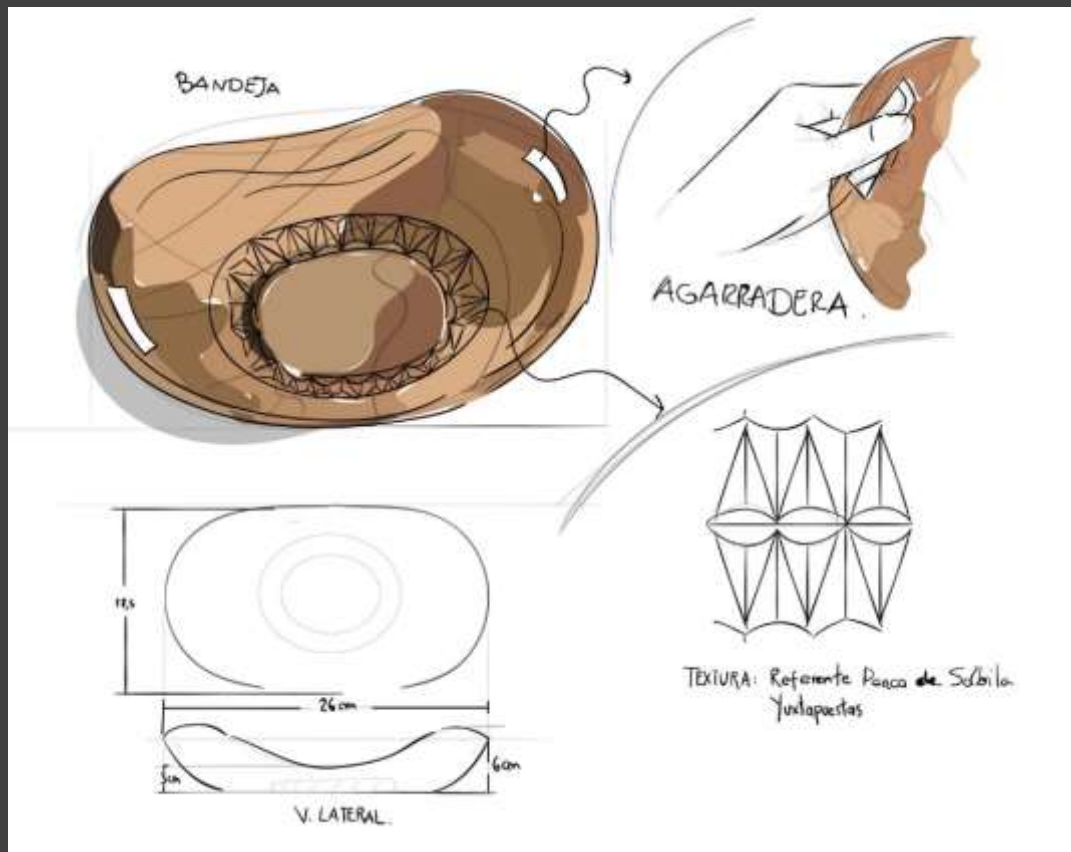

MATERIA
PRIMA



REFERENTE ARTESANO



SANTA MARTA



PALETA DE COLOR



El progreso
es de todos

Gobierno
de Colombia
Mincomercio



BOCETO O IDEA

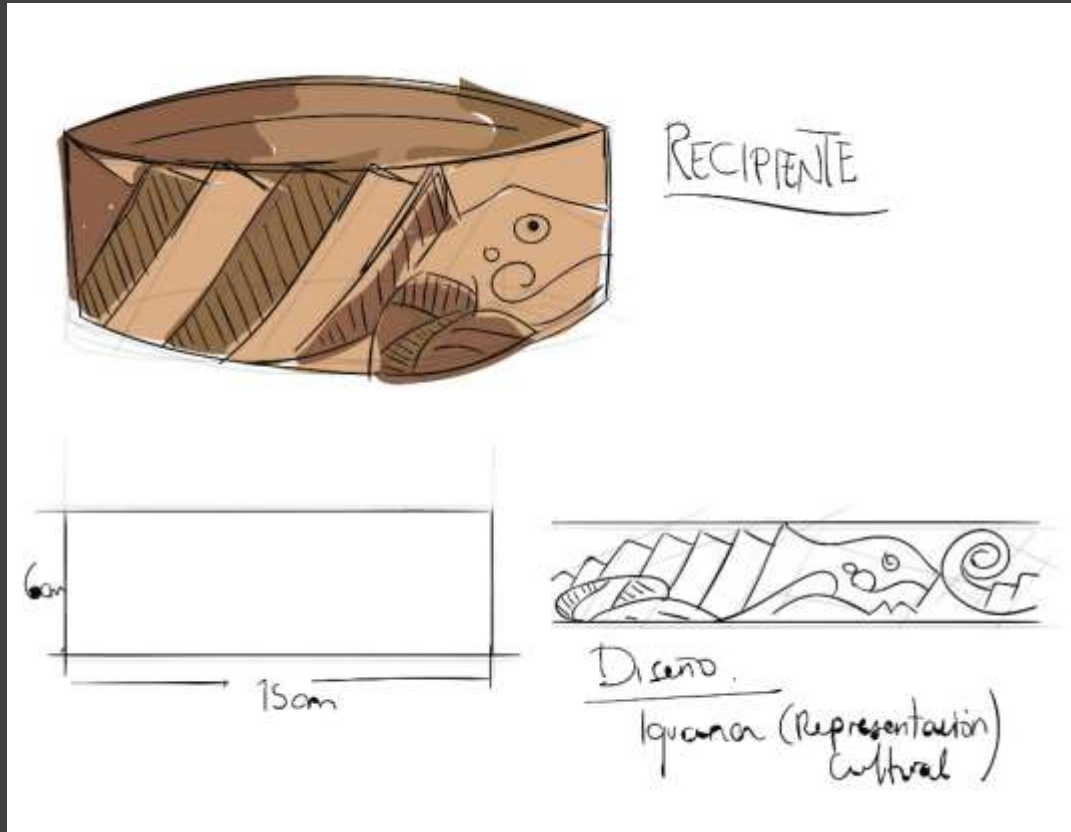

MATERIA
PRIMA



REFERENTE
ARTESANO

SANTA MARTA



PALETA DE
COLOR



El progreso
es de todos

Gobierno
de Colombia
Mincomercio



BOCETO O IDEA

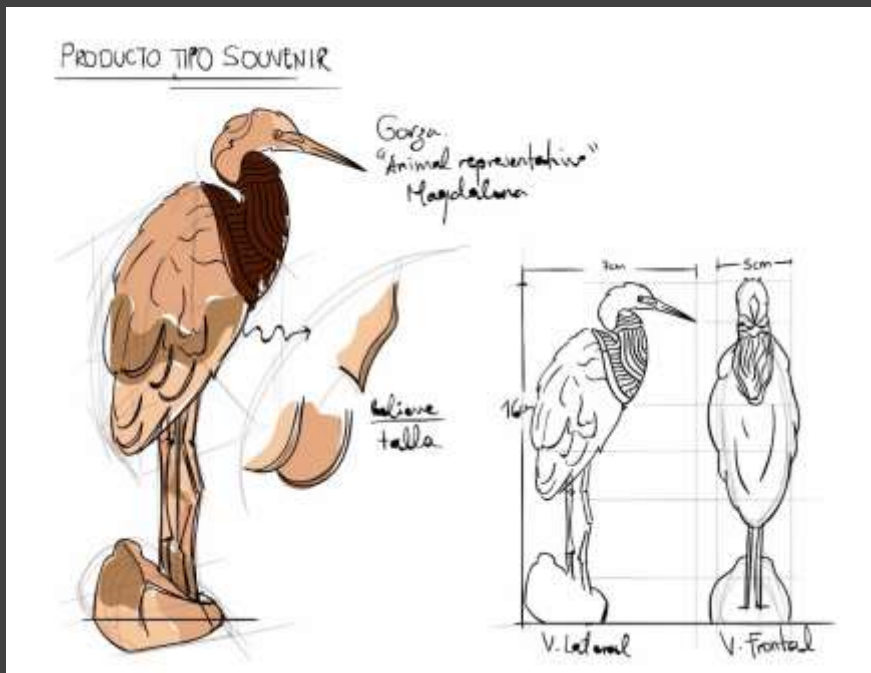

MATERIA
PRIMA



REFERENTE
ARTESANO

SANTA MARTA



PRODUCTO TIPO SOUVENIR
(REFERENTE MAGDALENA)

PALETA DE
COLOR



El progreso
es de todos

Gobierno
de Colombia
Mincomercio



BOCETO O IDEA

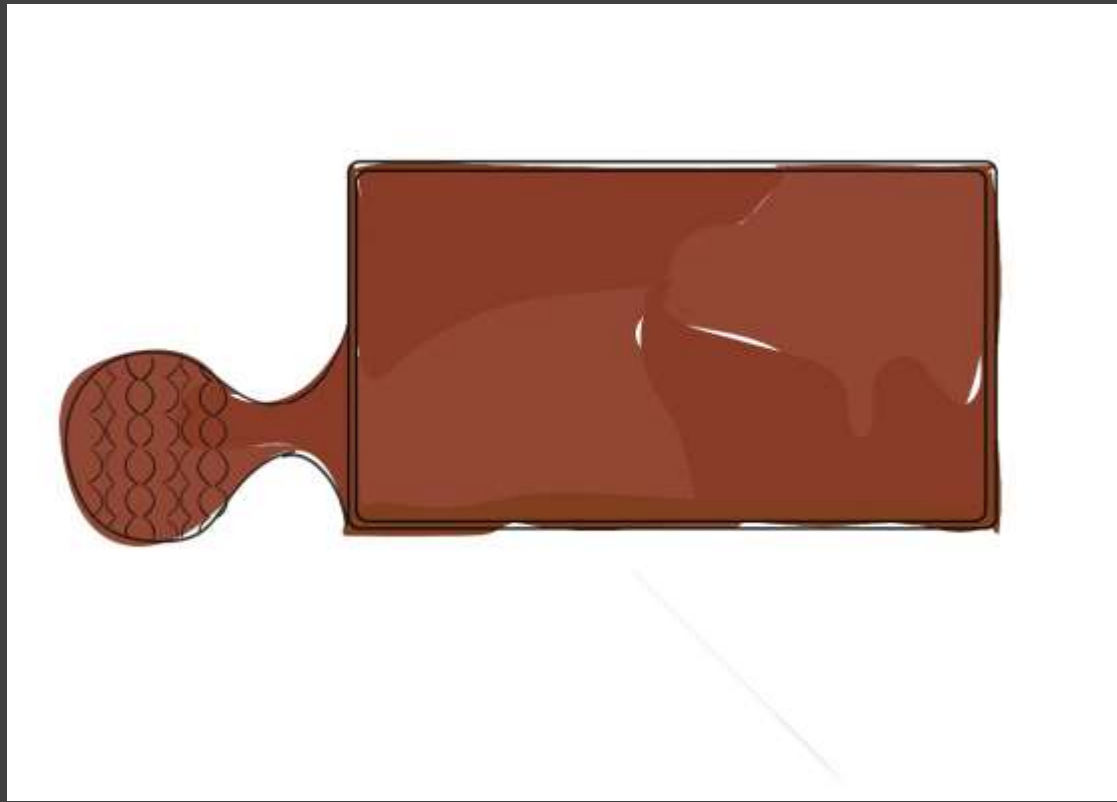

MATERIA PRIMA



REFERENTE ARTESANO



Bordes espinos de la sábila

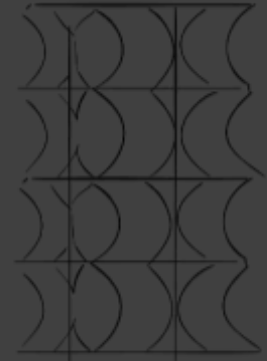

SANTA MARTA



PALETA DE COLOR



El progreso es de todos

Gobierno de Colombia
Mincomercio



BOCETO O IDEA

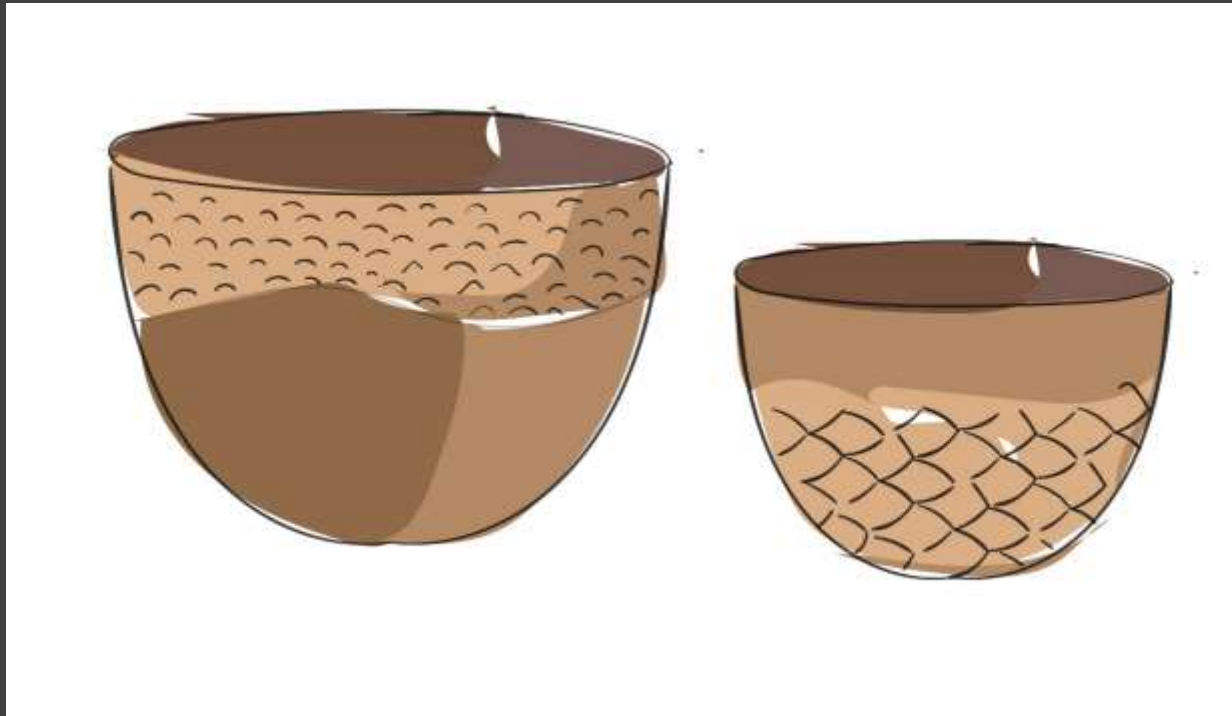

MATERIA
PRIMA



REFERENTE
ARTESANO

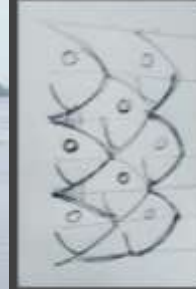

SANTA MARTA



PALETA DE
COLOR



El progreso
es de todos

Gobierno
de Colombia
Mincomercio



artesanías de colombia

BOCETO O IDEA



REFERENTE
ARTESANO



EL BANCO



MATERIA
PRIMA



PALETA DE
COLOR



El progreso
es de todos

Gobierno
de Colombia
Mincomercio



BOCETO O IDEA

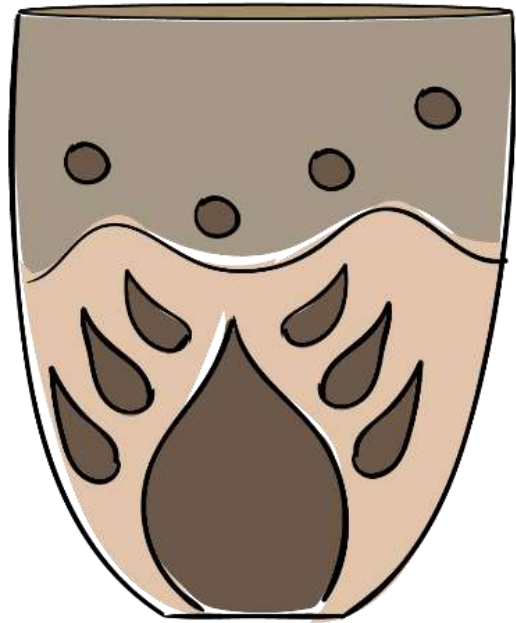

REFERENTE
ARTESANO



EL BANCO



MATERIA
PRIMA



PALETA DE
COLOR



El progreso
es de todos

Gobierno
de Colombia
Mincomercio



BOCETO O IDEA

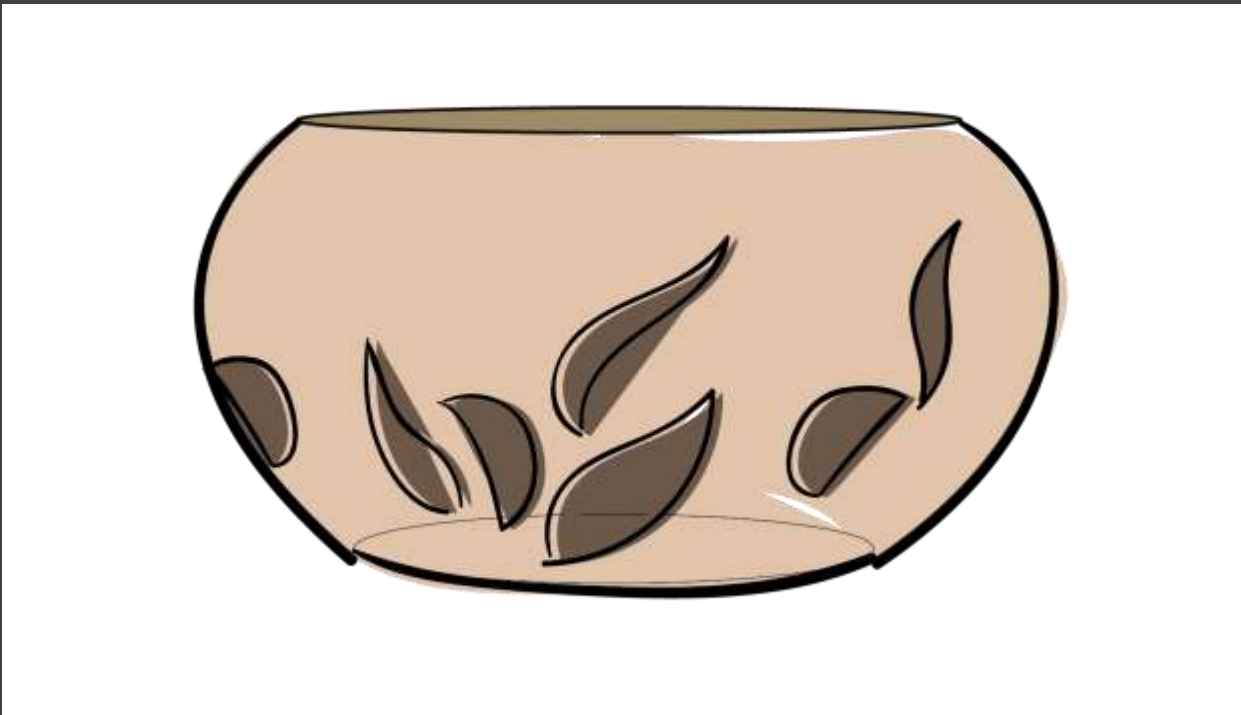

REFERENTE
ARTESANO



EL BANCO



MATERIA
PRIMA



PALETA DE
COLOR



El progreso
es de todos

Gobierno
de Colombia
Mincomercio



BOCETO O IDEA



REFERENTE ARTESANO

CONCEPTOS APLICADOS
COLOR- DIVERSIFICACIÓN

SAN SEBASTIÁN DE BUENAVISTA



MATERIA PRIMA



PALETA DE COLOR



El progreso
es de todos

Gobierno
de Colombia
Mincomercio



artesanías de colombia

BOCETO O IDEA

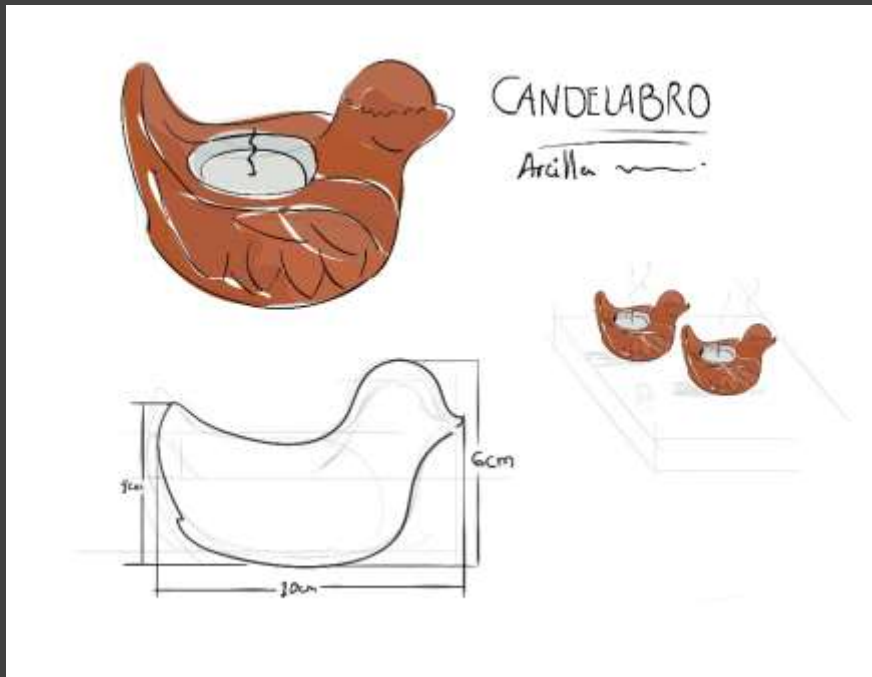

REFERENTE ARTESANO

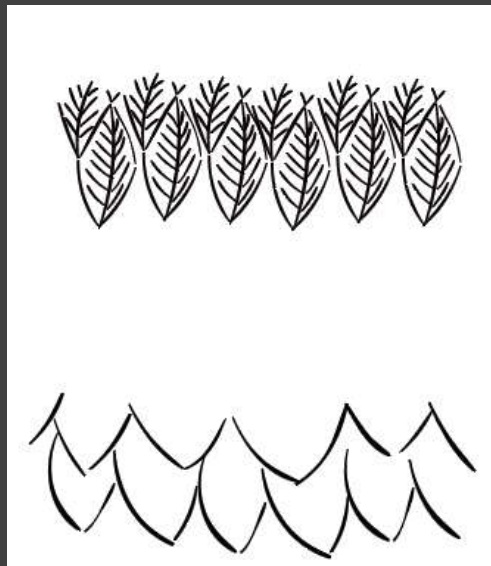

SANTA MARTA



MATERIA PRIMA



PALETA DE COLOR



El progreso
es de todos

Gobierno
de Colombia
Mincomercio



artesanías de Colombia



MAGDALENA

Evolución Propuestas de Diseño



LABORATORIOS DE
INNOVACIÓN
Y DISEÑO

BOCETO O IDEA

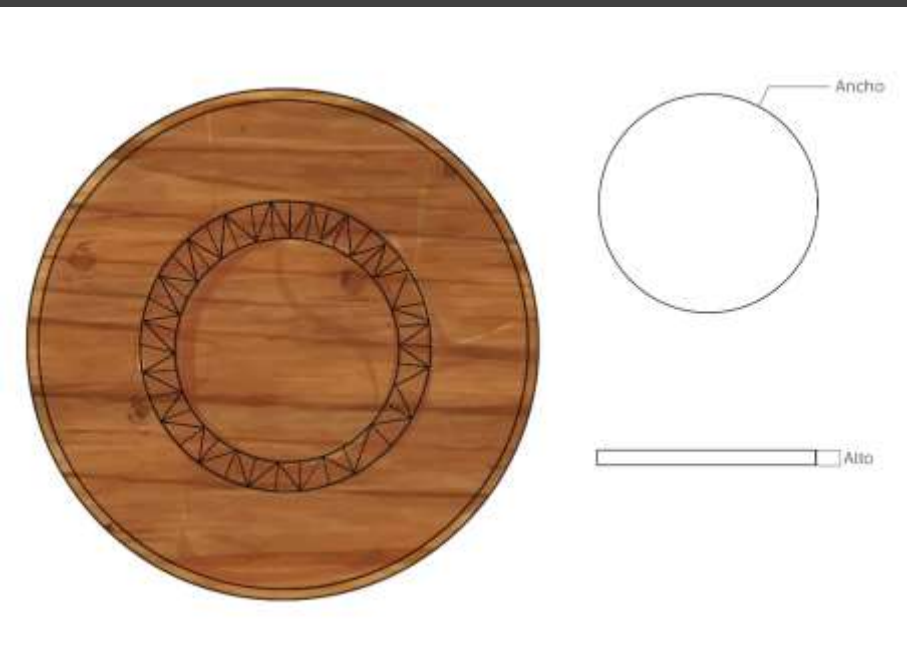

REFERENTE ARTESANO



SANTA MARTA



Oficio: Trabajo en Madera

Técnica: Talla

Materia prima: Madera

Artesano: Farid Florez

Nombre del producto: Tabla de quesos

Medidas: LARGO X ALTO X ANCHO (cm):
4 x Ø30

Diseñador Local : Luzángela Brito

Diseñador Líder: Natalia Quiñones

MATERIA PRIMA



PALETA DE COLOR



El progreso
es de todos

Gobierno
de Colombia
Mincomercio



BOCETO O IDEA

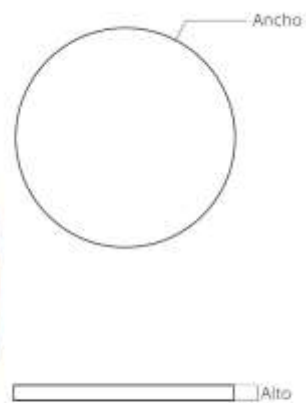

REFERENTE ARTESANO



SANTA MARTA



Oficio: Trabajo en Madera

Técnica: Talla

Materia prima: Madera

Artesano: Farid Florez

Nombre del producto: Tabla de quesos

Medidas: LARGO X ALTO X ANCHO (cm):
4 x Ø30

Diseñador Local : Luzángela Brito

Diseñador Líder: Natalia Quiñones

MATERIA PRIMA



PALETA DE COLOR



El progreso
es de todos

Gobierno
de Colombia
Mincomercio



BOCETO O IDEA

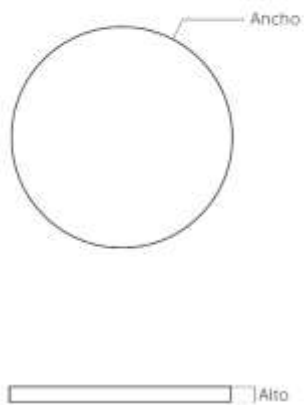

REFERENTE ARTESANO



SANTA MARTA



Oficio: Trabajo en Madera

Técnica: Talla

Materia prima: Madera

Artesano: Farid Florez

Nombre del producto: Tabla de quesos

Medidas: LARGO X ALTO X ANCHO (cm):
4 x Ø30

Diseñador Local : Luzángela Brito

Diseñador Líder: Natalia Quiñones

MATERIA PRIMA



PALETA DE COLOR



El progreso
es de todos

Gobierno
de Colombia
Mincomercio



BOCETO O IDEA

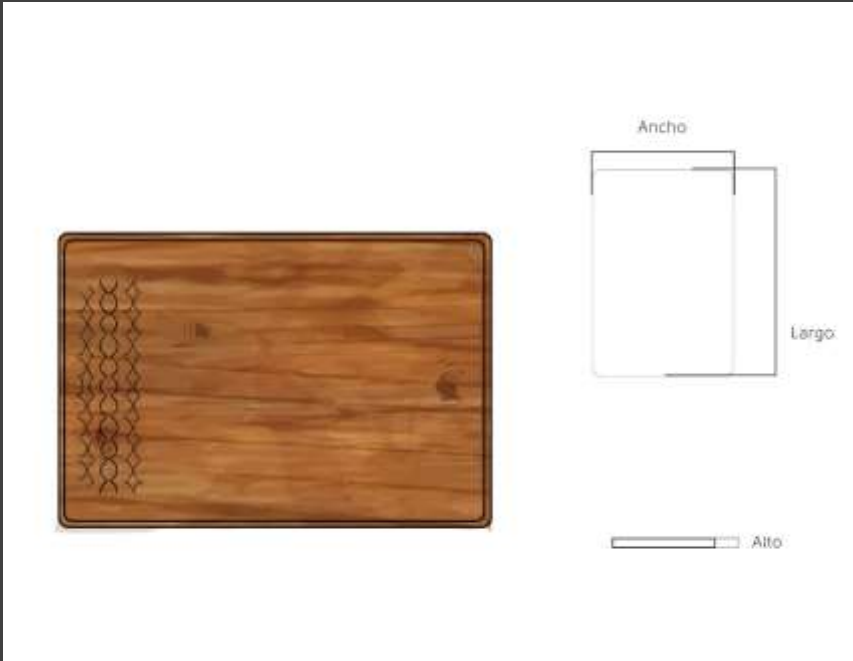

MATERIA PRIMA



REFERENTE ARTESANO

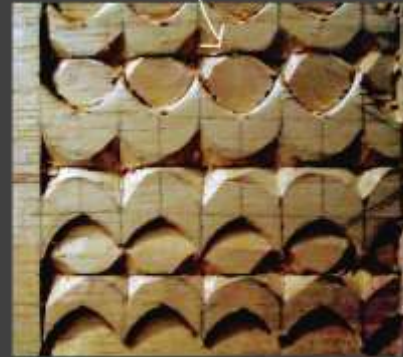

Bordes espinos de la sábila



PALETA DE COLOR



SANTA MARTA



Oficio: Trabajo en Madera

Técnica: Talla

Materia prima: Madera

Artesano: Farid Florez

Nombre del producto: Tabla de picar

Medidas: LARGO X ALTO X ANCHO (cm):
40x3x22

Diseñador Local : Luzángela Brito

Diseñador Líder: Natalia Quiñones



El progreso
es de todos

Gobierno
de Colombia
Mincomercio



BOCETO O IDEA

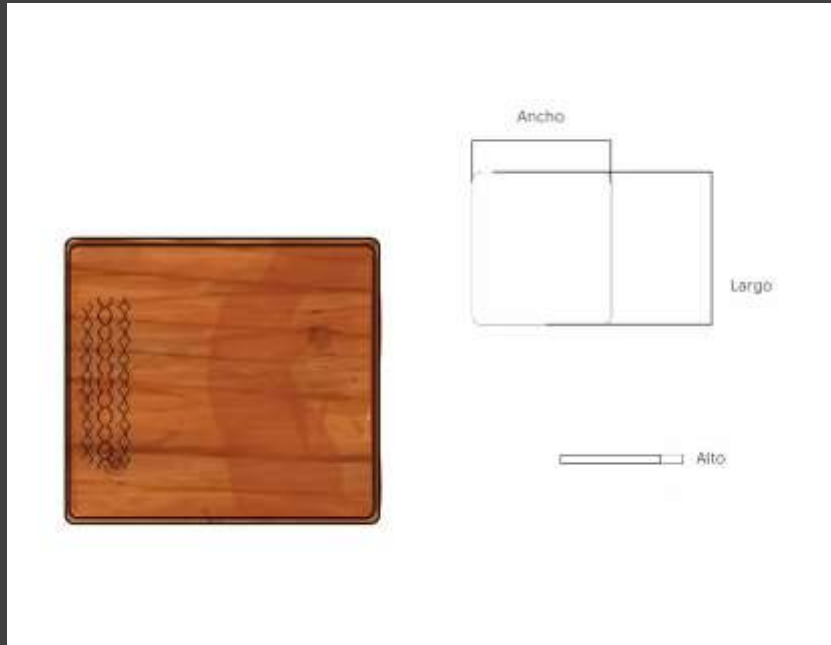

MATERIA PRIMA



REFERENTE ARTESANO

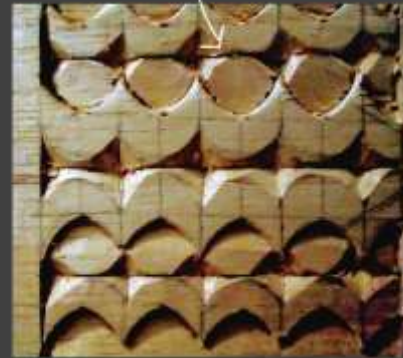

Bordes espinos de la sábila



PALETA DE COLOR



SANTA MARTA



Oficio: Trabajo en Madera

Técnica: Talla

Materia prima: Madera

Artesano: Farid Florez

Nombre del producto: Tabla de picar

Medidas: LARGO X ALTO X ANCHO (cm):
32x3x22

Diseñador Local : Luzángela Brito

Diseñador Líder: Natalia Quiñones



El progreso
es de todos

Gobierno
de Colombia
Mincomercio



BOCETO O IDEA

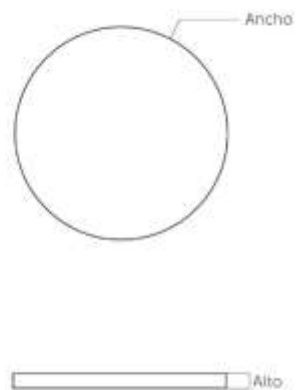

REFERENTE ARTESANO



Bordes espinos de la sábila

MATERIA PRIMA



PALETA DE COLOR



SANTA MARTA



Oficio: Trabajo en Madera

Técnica: Talla

Materia prima: Madera

Artesano: Farid Florez

Nombre del producto: Tabla de queso

Medidas: LARGO X ALTO X ANCHO (cm):
2 x Ø28

Diseñador Local : Luzángela Brito

Diseñador Líder: Natalia Quiñones



El progreso
es de todos

Gobierno
de Colombia
Mincomercio



BOCETO O IDEA

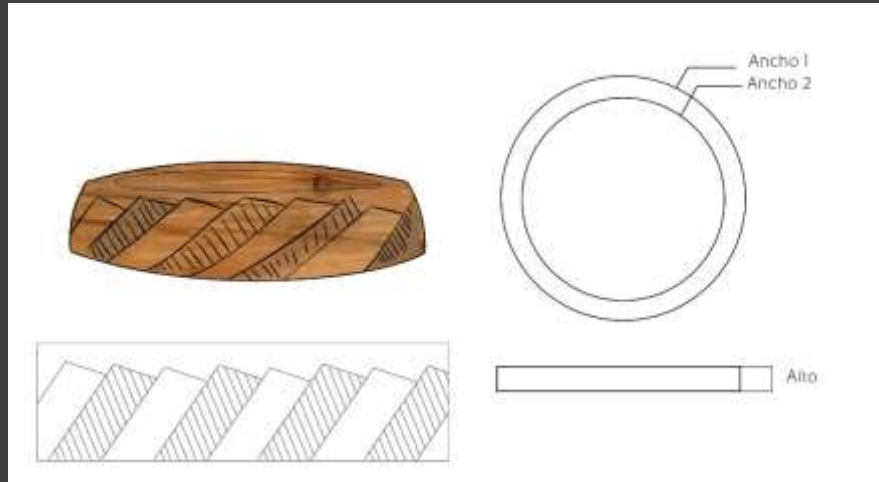

REFERENTE ARTESANO

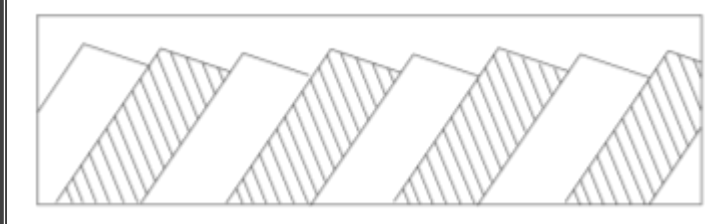

SANTA MARTA



Oficio: Trabajo en Madera

Técnica: Talla

Materia prima: Madera

Artesano: Farid Flore

Nombre del producto: Plato Hondo

Medidas: ALTO X ANCHO 1 X ANCHO 2

(cm): 5 x 20 x 18

Diseñador Local : Luzángela Brito

Diseñador Líder: Natalia Quiñones

MATERIA PRIMA



PALETA DE COLOR



El progreso
es de todos

Gobierno
de Colombia
Mincomercio



BOCETO O IDEA

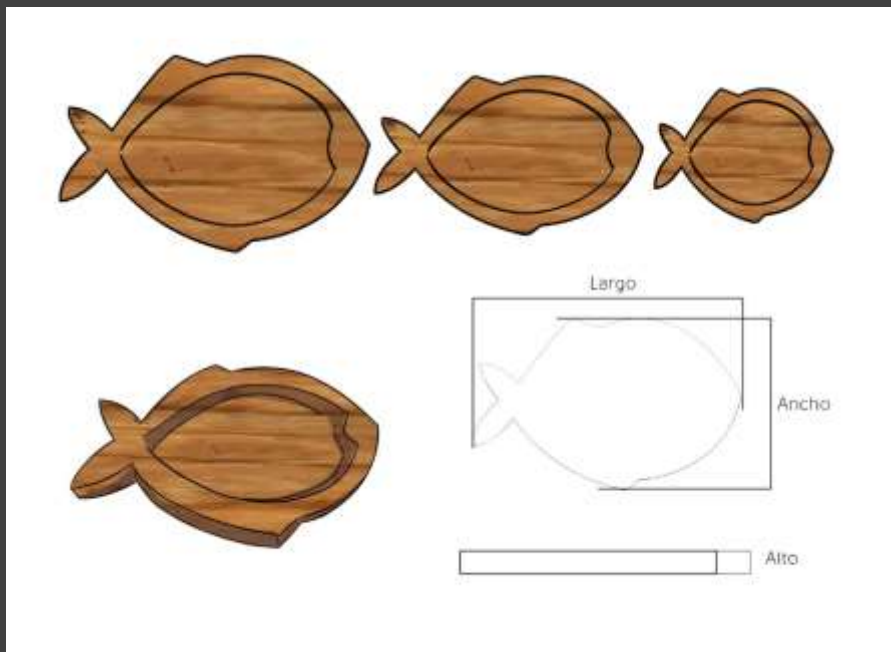

REFERENTE ARTESANO



SANTA MARTA



Oficio: Trabajo en Madera

Técnica: Talla

Materia prima: Madera

Artesano: Farid Florez

Nombre del producto: Plato/Bandeja
Pez

Medidas: LARGO X ALTO X ANCHO (cm)

Grande: 27 x 3 x 30

Mediano: 24 x 3 x 15

Pequeño: 20 x 2 x 15

Diseñador Local : Luzángela Brito

Diseñador Líder: Natalia Quiñones

MATERIA PRIMA



PALETA DE COLOR



El progreso
es de todos

Gobierno
de Colombia
Mincomercio



artesanías de colombia



Elaboración de prototipo – propuesta inicial



El progreso
es de todos

Gobierno
de Colombia
Mincomercio



artesanías de colombia

BOCETO O IDEA



REFERENTE ARTESANO

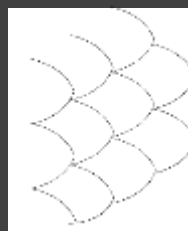

MOVIMIENTO DEL AGUA

PECES

SANTA MARTA



Oficio: Trabajo en Madera

Técnica: Talla

Materia prima: Madera

Artesano: Farid Florez

Nombre del producto: Bowl

Medidas: ALTO X ANCHO (cm)

Grande: 12 x25

Pequeño: 10 x 20

Diseñador Local : Luzángela Brito

Diseñador Líder: Natalia Quiñones

MATERIA PRIMA



PALETA DE COLOR



El progreso es de todos

Gobierno de Colombia
Mincomercio



BOCETO O IDEA

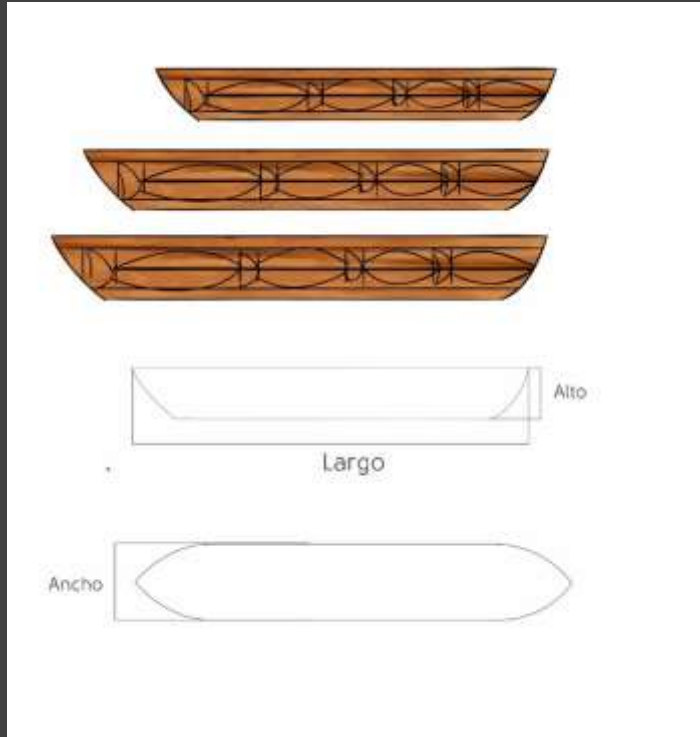

MATERIA PRIMA



REFERENTE ARTESANO

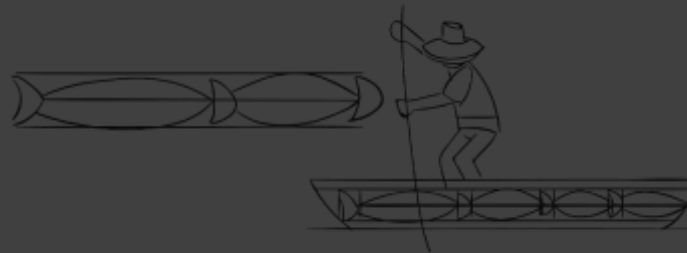

PALETA DE COLOR



SANTA MARTA



Oficio: Trabajo en Madera

Técnica: Talla

Materia prima: Madera

Artesano: Farid Florez

Nombre del producto: Souvenir - Canoas

Medidas: LARGO X ALTO X ANCHO (cm)

Grande: 20 x 3,5 x 4

Mediano: 17 x 3,5 x 4

Pequeño: 15 x 3,5 x 4

Diseñador Local : Luzángela Brito

Diseñador Líder: Natalia Quiñones



El progreso
es de todos

Gobierno
de Colombia
Mincomercio



BOCETO O IDEA



REFERENTE ARTESANO



MATERIA PRIMA



PALETA DE COLOR



SANTA MARTA



Oficio: Trabajo en Madera

Técnica: Talla

Materia prima: Madera

Artesano: Farid Florez

Nombre del producto: Souvenir –
Canoas y pescador

Medidas: LARGO X ALTO X ANCHO (cm)

Diseñador Local : Luzángela Brito

Diseñador Líder: Natalia Quiñones



El progreso
es de todos

Gobierno
de Colombia
Mincomercio



BOCETO O IDEA



REFERENTE ARTESANO

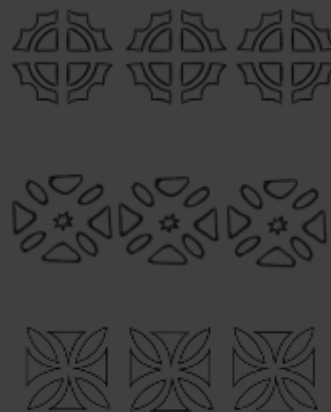

CIÉNAGA



Oficio: Trabajo en totumo

Técnica: Calado

Materia prima: Totumo

Artesano: Luz Estela Torres

Nombre del producto: Recipientes colgantes

Costo aprox:

Medidas: LARGO X ALTO X ANCHO (cm)

Diseñador Local: Luzángela Brito

Diseñador Líder: Natalia Quiñones

MATERIA PRIMA



PALETA DE COLOR



El progreso
es de todos

Gobierno
de Colombia
Mincomercio



artesanías de colombia

BOCETO O IDEA

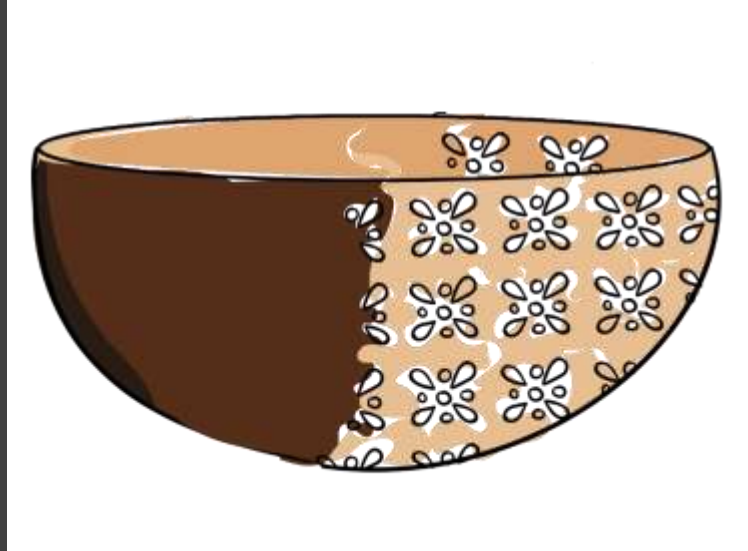

REFERENTE ARTESANO



CIÉNAGA



Oficio: Trabajo en totumo

Técnica: Calado

Materia prima: Totumo

Artesano: Luz Estela Torres

Nombre del producto: Contenedor
cienagero

Diseñador Local: Luzángela Brito

Diseñador Líder: Natalia Quiñones

MATERIA PRIMA



PALETA DE COLOR



El progreso
es de todos

Gobierno
de Colombia
Mincomercio



BOCETO O IDEA



REFERENTE ARTESANO



CIÉNAGA



Oficio: Trabajo en totumo

Técnica: Calado

Materia prima: Totumo

Artesano: Luz Estela Torres

Nombre del producto: Contenedor
cienagero

Diseñador Local: Luzángela Brito

Diseñador Líder: Natalia Quiñones

MATERIA PRIMA



PALETA DE COLOR



El progreso
es de todos

Gobierno
de Colombia
Mincomercio



BOCETO O IDEA

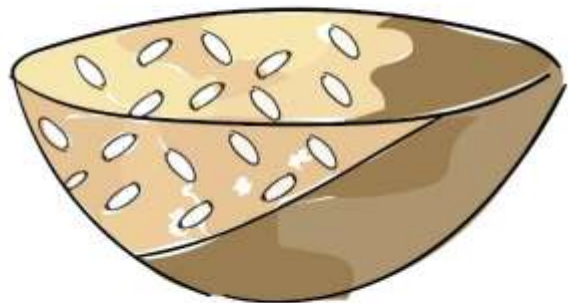

REFERENTE ARTESANO



CIÉNAGA



Oficio: Trabajo en totumo

Técnica: Calado

Materia prima: Totumo

Artesano: Luz Estela Torres

Nombre del producto: Contenedor
cienagero

Diseñador Local: Luzángela Brito

Diseñador Líder: Natalia Quiñones

MATERIA PRIMA



PALETA DE COLOR



El progreso
es de todos

Gobierno
de Colombia
Mincomercio



BOCETO O IDEA

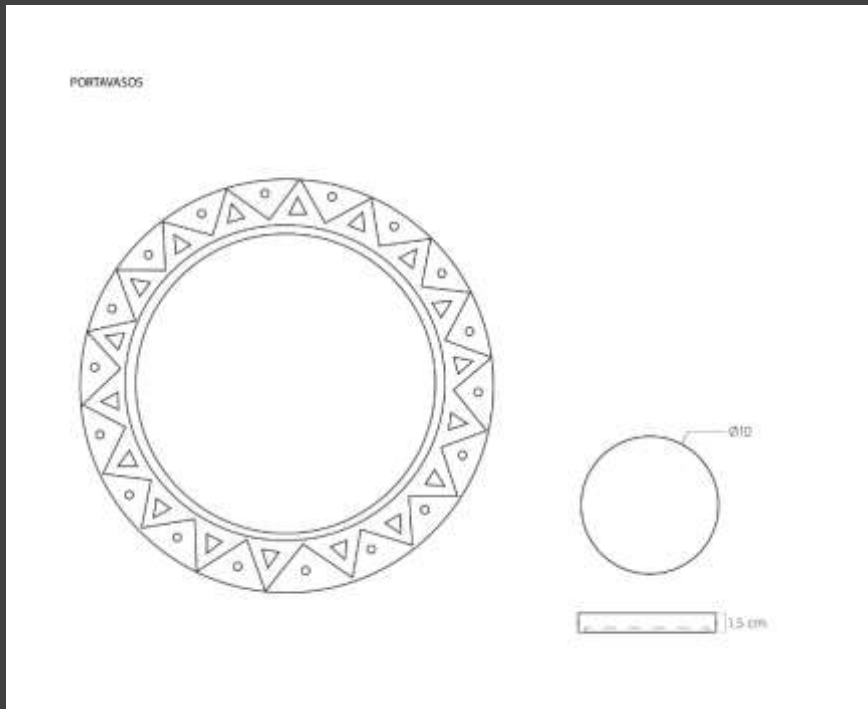

REFERENTE ARTESANO



SANTA MARTA



Oficio: Trabajo en Piedra de Jabón

Técnica: Talla

Materia prima: Piedra

Artesano: Grupo piedra de Jabón Santa Marta- Alejandro Pertuz – Edinson

Nombre del producto: Portavasos

Diseñador Local: Luzángela Brito

Diseñador Líder: Natalia Quiñones

MATERIA PRIMA



PALETA DE COLOR



El progreso
es de todos

Gobierno
de Colombia
Mincomercio



BOCETO O IDEA

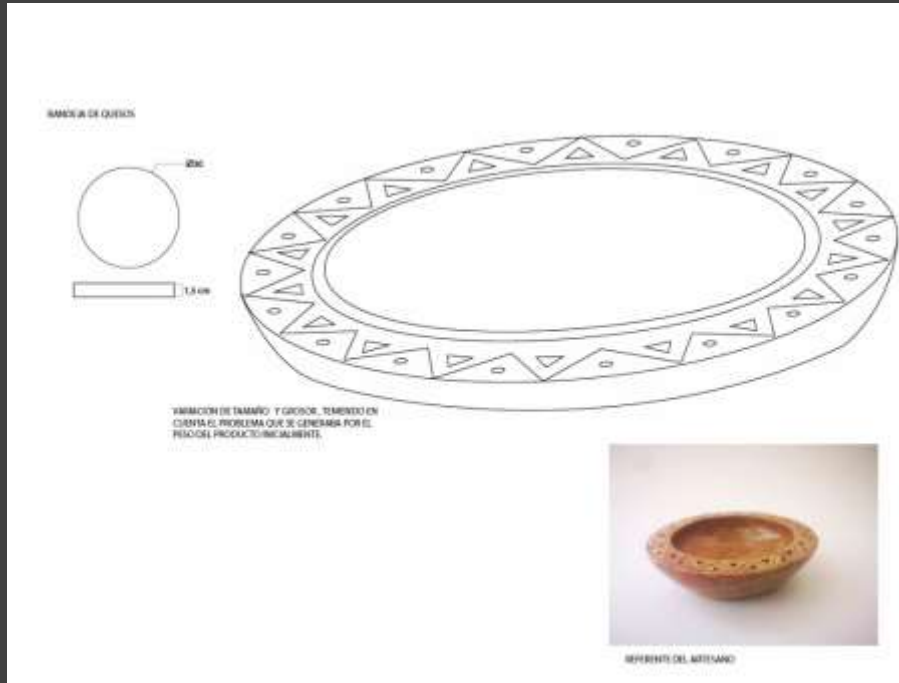

REFERENTE ARTESANO



SANTA MARTA



Oficio: Trabajo en Piedra de Jabón

Técnica: Talla

Materia prima: Piedra

Artesano: Grupo piedra de Jabón Santa Marta- Alejandro Pertuz, Edinson.

Nombre del producto: Plato

Diseñador Local: Luzángela Brito

Diseñador Líder: Natalia Quiñones

MATERIA PRIMA



PALETA DE COLOR



El progreso es de todos

Gobierno de Colombia
Mincomercio



BOCETO O IDEA

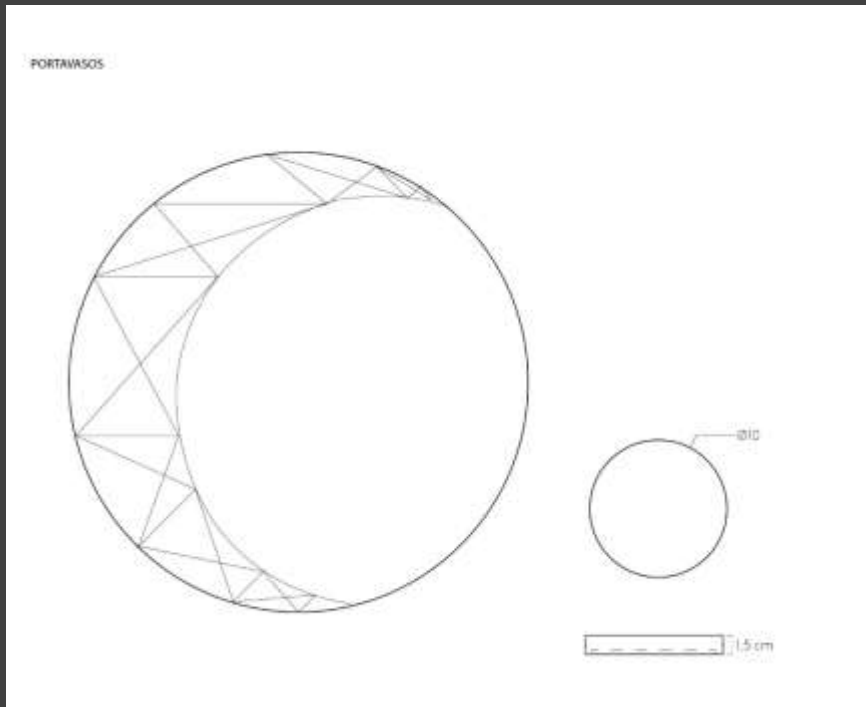

REFERENTE ARTESANO



SANTA MARTA



Oficio: Trabajo en Piedra de Jabón

Técnica: Talla

Materia prima: Piedra

Artesano: Grupo piedra de Jabón Santa Marta- Alejandro Pertuz – Edinson

Nombre del producto: Portavasos

Diseñador Local: Luzángela Brito

Diseñador Líder: Natalia Quiñones

MATERIA PRIMA



PALETA DE COLOR



El progreso
es de todos

Gobierno
de Colombia
Mincomercio



BOCETO O IDEA

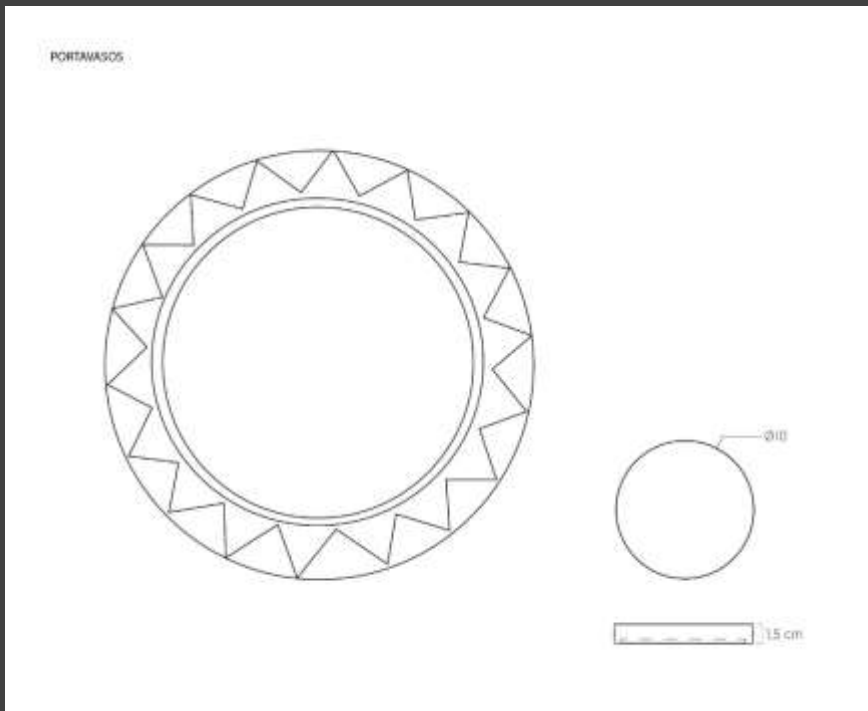

REFERENTE ARTESANO



SANTA MARTA



Oficio: Trabajo en Piedra de Jabón

Técnica: Talla

Materia prima: Piedra

Artesano: Grupo piedra de Jabón Santa Marta- Alejandro Pertuz – Edinson

Nombre del producto: Portavasos

Diseñador Local: Luzángela Brito

Diseñador Líder: Natalia Quiñones

MATERIA PRIMA



PALETA DE COLOR



El progreso
es de todos

Gobierno
de Colombia
Mincomercio



BOCETO O IDEA

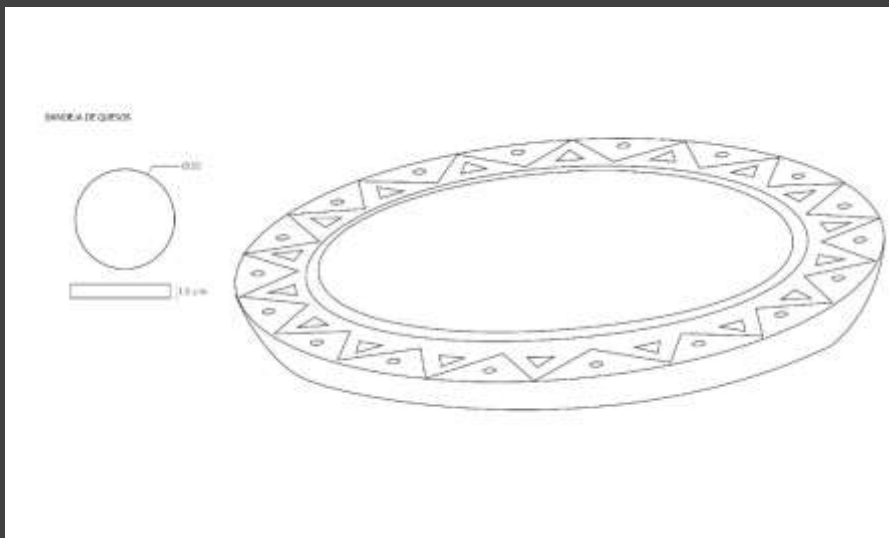

REFERENTE ARTESANO



SANTA MARTA



Oficio: Trabajo en Piedra de Jabón

Técnica: Talla

Materia prima: Piedra

Artesano: Grupo piedra de Jabón Santa Marta- Alejandro Pertuz – Edinson

Nombre del producto: Plato plano

Diseñador Local: Luzángela Brito

Diseñador Líder: Natalia Quiñones

MATERIA PRIMA



PALETA DE COLOR



El progreso
es de todos

Gobierno
de Colombia
Mincomercio



BOCETO O IDEA



REFERENTE ARTESANO



Máscaras de pared

SANTA MARTA



Oficio: Trabajo en Piedra de Jabón

Técnica: Talla

Materia prima: Piedra

Artesano: Grupo piedra de Jabón Santa
Marta- Alejandro Pertuz – Edinson

Nombre del producto: Máscaras
Diseñador Local: Luzángela Brito

Diseñador Líder: Natalia Quiñones

MATERIA PRIMA



PALETA DE COLOR



El progreso
es de todos

Gobierno
de Colombia
Mincomercio



BOCETO O IDEA

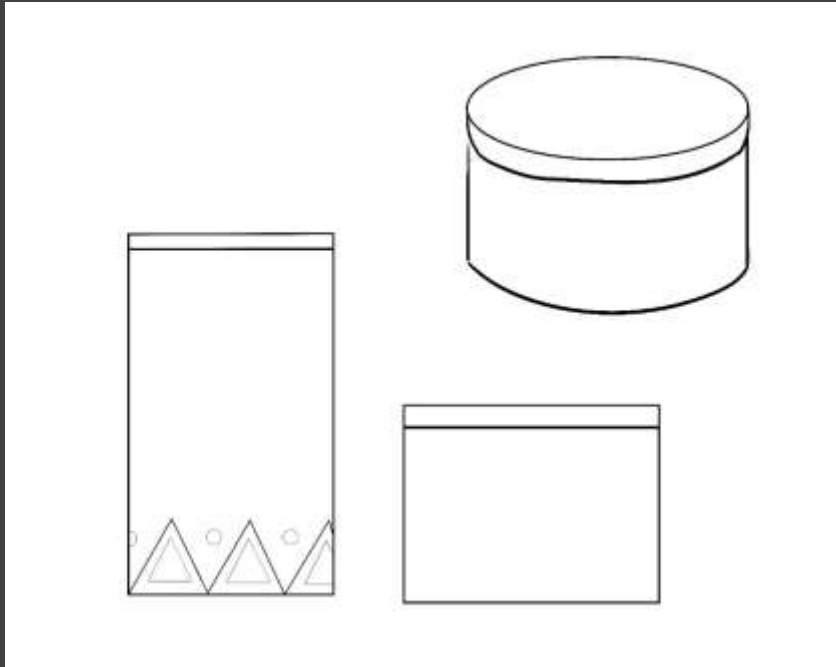

REFERENTE ARTESANO



SANTA MARTA



Oficio: Trabajo en Piedra de Jabón

Técnica: Talla

Materia prima: Piedra

Artesano: Grupo piedra de Jabón Santa
Marta- Alejandro Pertuz – Edinson

Nombre del producto: Recipientes
Diseñador Local: Luzángela Brito

Diseñador Líder: Natalia Quiñones

MATERIA PRIMA



PALETA DE COLOR



El progreso
es de todos

Gobierno
de Colombia
Mincomercio



BOCETO O IDEA

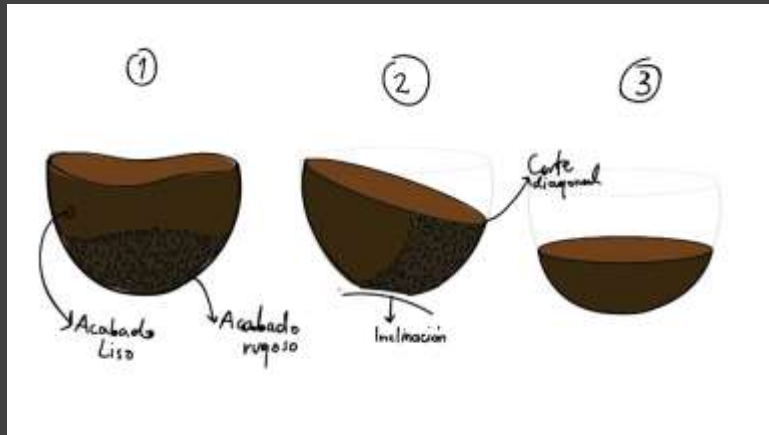

MATERIA PRIMA



REFERENTE ARTESANO



SANTA MARTA



Oficio: Trabajo en coco

Técnica: Talla, calado

Materia prima: coco

Artesano: Grupo Coco Santa Marta,
Líder Juan Pelaez (Maestro Artesano)

Nombre del producto: Recipientes

Diseñador Local: Luzángela Brito

Diseñador Líder: Natalia Quiñones

PALETA DE COLOR



El progreso
es de todos

Gobierno
de Colombia
Mincomercio



BOCETO O IDEA

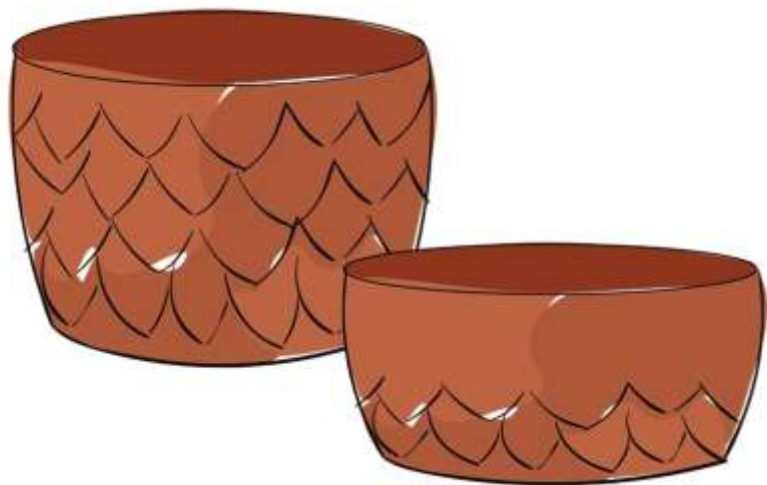

REFERENTE ARTESANO

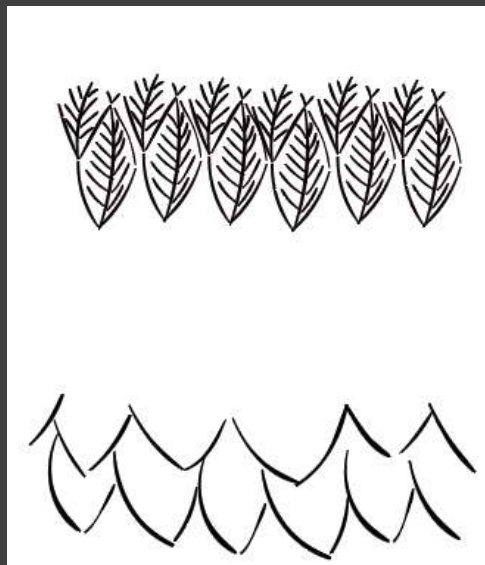

SANTA MARTA



Oficio: Trabajo con arcilla

Técnica: Alfarería

Materia prima: arcilla

Artesano: Olga Garcia

Nombre del producto: Recipientes

Diseñador Local: Luzángela Brito

MATERIA PRIMA



PALETA DE COLOR



El progreso
es de todos

Gobierno
de Colombia
Mincomercio



artesanías de colombia

BOCETO O IDEA



REFERENTE ARTESANO

CONCEPTOS APLICADOS COLOR- DIVERSIFICACIÓN

SAN SEBASTIÁN
DE BUENAVISTA



Oficio: Trabajo en fibras

Técnica: Tejeduría

Materia prima: Taruya

Artesano: ciro Rojas

Nombre del producto: Canastos

Costo aprox:

Medidas 50x 35, 40x25, 35x25 cm

Diseñador Regional: Luzángela Brito

Diseñador Líder: Natalia Quiñones

MATERIA PRIMA



PALETA DE COLOR



El progreso
es de todos

Gobierno
de Colombia
Mincomercio





TOTAL PRODUCTOS DISEÑADOS

RESULTADOS	MAGDALENA
EDICIÓN CASOS DE ÉXITO	0
PRODUCTOS NUEVOS DISEÑADOS	32
PRODUCTOS APROBADOS COMITÉ NACIONAL	0
PRODUCTOS PRODUCIDOS	0



El progreso
es de todos

Gobierno
de Colombia
Mincomercio



artesanías de colombia

“PIENSA BONITO,
HABLA BONITO,
TEJE BONITO...”

Hugo Jamioy, etnia Kamëntsá

