

artesanías  
de colombia



EXPEDICIÓN ORINOCO  
RECORRIENDO IDENTIDADES ANCESTRALES

# Resultados diseño, producción y comercial - 2020



EXPEDICIÓN ORINOCO  
RECORRIENDO IDENTIDADES ANCESTRALES



El progreso  
es de todos

Gobierno  
de Colombia  
Mincomercio



## REGIÓN ORINOQUÍA

Arauca, Caquetá, Casanare, Guainía, Meta, Vaupés

Se relacionan resultados significativos a nivel de producción y diseño y comercial.



### Total:

- **6** departamentos
  - **8** municipios
- **12** talleres o unidades productivas con resultados a nivel de producto y/o comercial
  - **5** oficios

Marroquinería- alfarería – tejeduría – cestería – trabajo en madera

- **80** propuestas de productos
- **65** propuestas de productos aprobadas para colección nacional.
  - **7** escenarios de oportunidades comerciales. Incluye 3 ferias nacionales virtuales .
- **\$ 27.129.000** oportunidades comerciales



Arauca

1 G



Solano Milán

2 G



Hato Corozal

1 G



Inírida

2 G



Cabuyaro  
Puerto Gaitán

3 G



Mitú

3 G



- Alfarería
- Cestería
- Marroquinería
- Tejeduría
- Trabajo en madera

**80** propuestas de producto  
**60** aprobados para Colección  
 Nacional



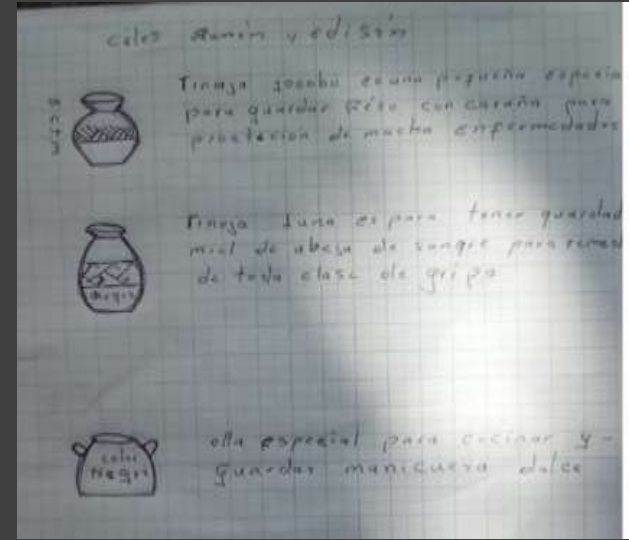

## Producción:

- Identificación de necesidades de materias primas
  - Talleres de acuerdos de calidad
    - Mejoramiento técnico
  - Taller transferencia de saberes

## Diseño:

- Identidad y referentes
- Talleres de diversificación
  - Talleres de texturas
- Elaboración de prototipos
  - Línea y colección
  - Tendencias

Comercial:

Ferias

Otras oportunidades

Órdenes de compra



[www.expoartesano.com.co/](http://www.expoartesano.com.co/)

- *Compras de apoyo*
- *Folk Art*
- *Arte Vivo*
- *20 comunidades*

- *8 Grupos con órdenes de compra*



*Marketplace*

8 Escenarios de oportunidad comercial  
**\$ 27.129.000** aprobados para Colección Nacional

REGIÓN  
ORINOCO

**META**



El progreso  
es de todos

Gobierno  
de Colombia  
Mincomercio





Referente



# COOPERATIVA ARFIPLAT

**Municipio:** Vereda El Viso de Upía, Cabuyaro  
**Etnia:** N.A. Mujeres campesinas, madres cabeza de familia.

**Materia prima:** Fibra de plátano, iraca, madera, cuero.

**Oficio:** Tejeduría.

**Técnica:** Tejido en rollo, telar

**Número de artesanos:** 25

NIVEL 1



El progreso  
es de todos

Gobierno  
de Colombia  
Mincomercio





**Referente**

**Tejeduría en Fibra de Plátano  
Cabuyaro, Meta  
Cooperativa Arfiplat  
Tejido en rollo – tejido de punto  
Alma de iraca  
Diferentes tonalidades tierra (tintes naturales)  
Mezcla con fique de color.**



**Referente**







## REFERENT E

Oficio: Tejeduría

Técnica: Tejido en rollo, tejido de punto, crochet

Materia prima: Fibra de plátano, iraca

Artesano: Ana Isabel Jagua

Nombre del producto: Canasto redondo grande, canasto redondo mediano, canasto redondo pequeño.



El progreso  
es de todos

Gobierno  
de Colombia  
Mincomercio



artesanías de colombia

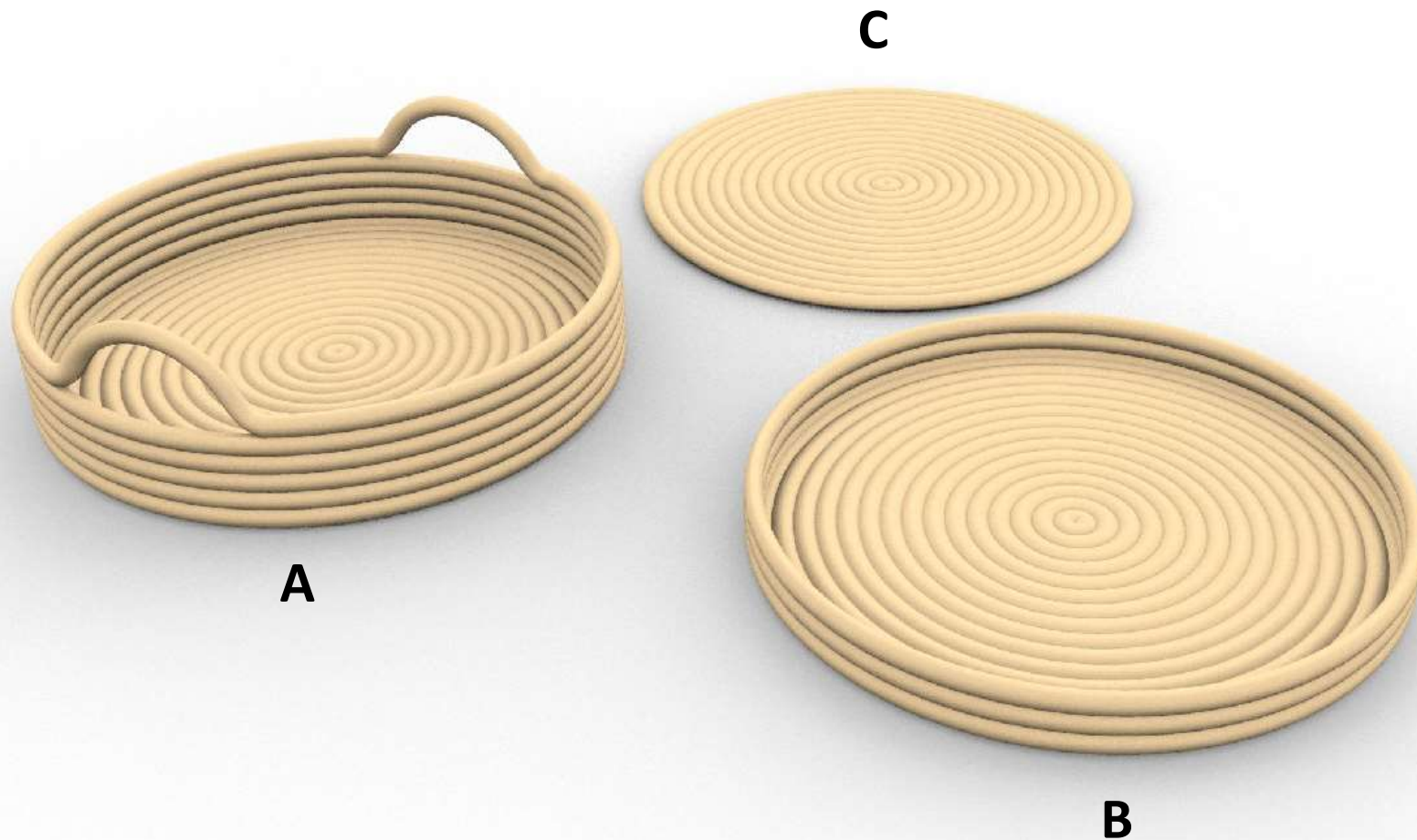

**REFERENT**  
**E**

Oficio: Tejeduría

Técnica: Tejido en rollo, tejido de punto, crochet

Materia prima: Fibra de plátano, iraca

Artesano: Ana Isabel Jagua

Nombre del producto: A. Contenedor con asas, B. Contenedor redondo, C. Centro de mesa.



El progreso  
es de todos

Gobierno  
de Colombia  
Mincomercio



artesanías de colombia



## REFERENT E

Oficio: Tejeduría

Técnica: Tejido en rollo, tejido de punto, crochet

Materia prima: Fibra de plátano, iraca

Artesano: Ana Isabel Jagua

Nombre del producto: Mesa auxiliar grande,  
mesa auxiliar pequeña.



El progreso  
es de todos

Gobierno  
de Colombia  
Mincomercio



artesanías de colombia



## ASOCIACION JONOBUTOWA– RESGUARDO INDIGENA WACOYO, COMUNIDAD SIKUANI.

**Municipio:** Puerto Gaitán

**Etnia:** Sikuani

**Materia prima:** Cumare

**Oficio:** Tejeduría

**Técnica:** Tejido en rollo, tejido cruzado

**Número de artesanos:** 20

**NIVEL 1**



El progreso  
es de todos

Gobierno  
de Colombia  
Mincomercio





**Referente**

**Tejeduría en Cumare  
Puerto Gaitán, Meta  
Jonobutowa  
Mujeres del resguardo indígena Wacoyo  
Tejido en rollo – tejido de punto  
Alma de iraca  
Diferentes tonalidades tierra (tintes naturales).**



**Referente**



## REFERENT

E

Oficio: Tejeduría

Técnica: Tejido en rollo. Materia prima: Cumare

Artesano: Nelsy Cortés

Nombre del producto: Contenedor flor grande, contenedor flor mediano, contenedor flor pequeño.



El progreso  
es de todos

Gobierno  
de Colombia  
Mincomercio



artesanías de colombia



#### REFERENT

E

Oficio: Tejeduría

Técnica: Tejido en rollo. Materia prima: Cumare

Artesano: Nelsy Cortés

Nombre del producto: Contenedor flor grande, contenedor flor mediano, contenedor flor pequeño.



El progreso  
es de todos

Gobierno  
de Colombia  
Mincomercio



artesanías de colombia

REGIÓN  
ORINOCO

**ARAUCA**



El progreso  
es de todos

Gobierno  
de Colombia  
Mincomercio







### Referente



## ASOCIACIÓN RED DE TURISMO COMUNITARIA DE ARAUCA - TUREDCO.

**Municipio:** Arauca.

**Etnia:** N.A. Mestizos, Indígenas, Afro.

**Materia prima:** Madera, cacho, cuero, bejuco, materiales reciclables, fibras.

**Oficio:** Madera, cacho, bisutería indígena, marroquinería, bejuco, trabajos en fibras vegetales.

**Técnica:** Mixtas.

**Número de artesanos:** 80

**NIVEL 1**



El progreso  
es de todos

Gobierno  
de Colombia  
Mincomercio



## Tipos de Puntadas a mano sobre cuero



Marroquinería  
Arauca, Arauca

Grupo: Asociación TUREDCO

Técnicas: Preformado, repujado, calado, moldeado  
Cueros (bovino o vacuno)

Tipos de cuero: piel con pelo, cuero flor natural,  
nobuk, pieles vueltas (carnaza).

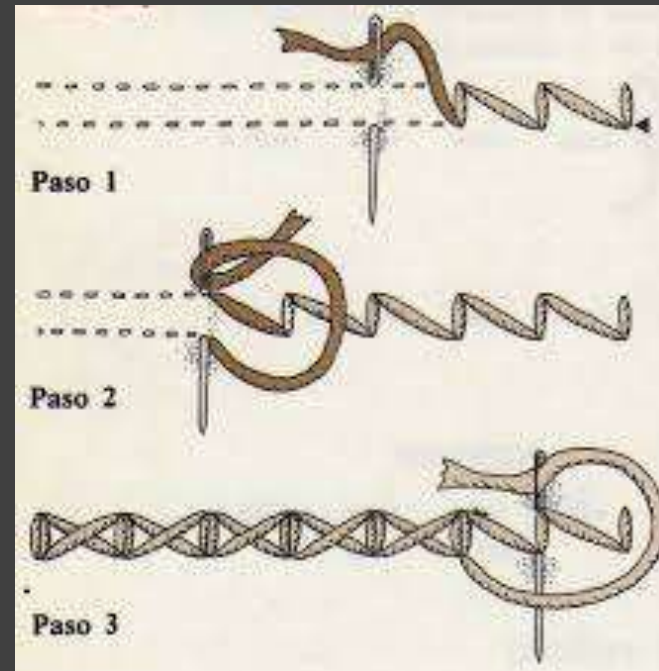
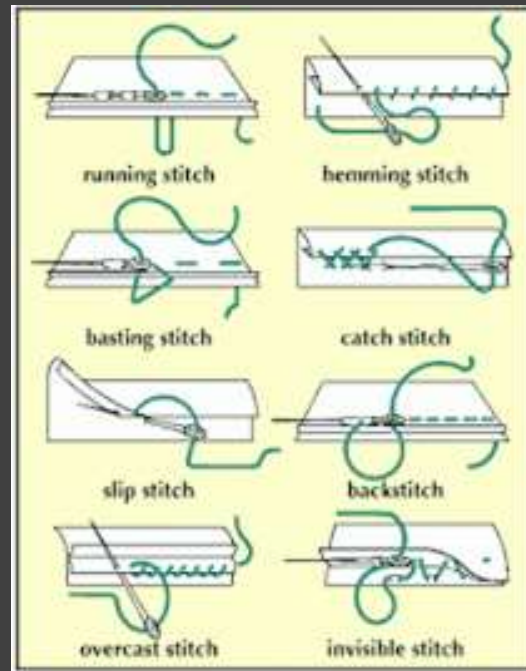

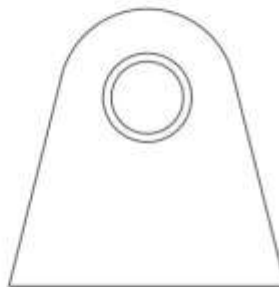
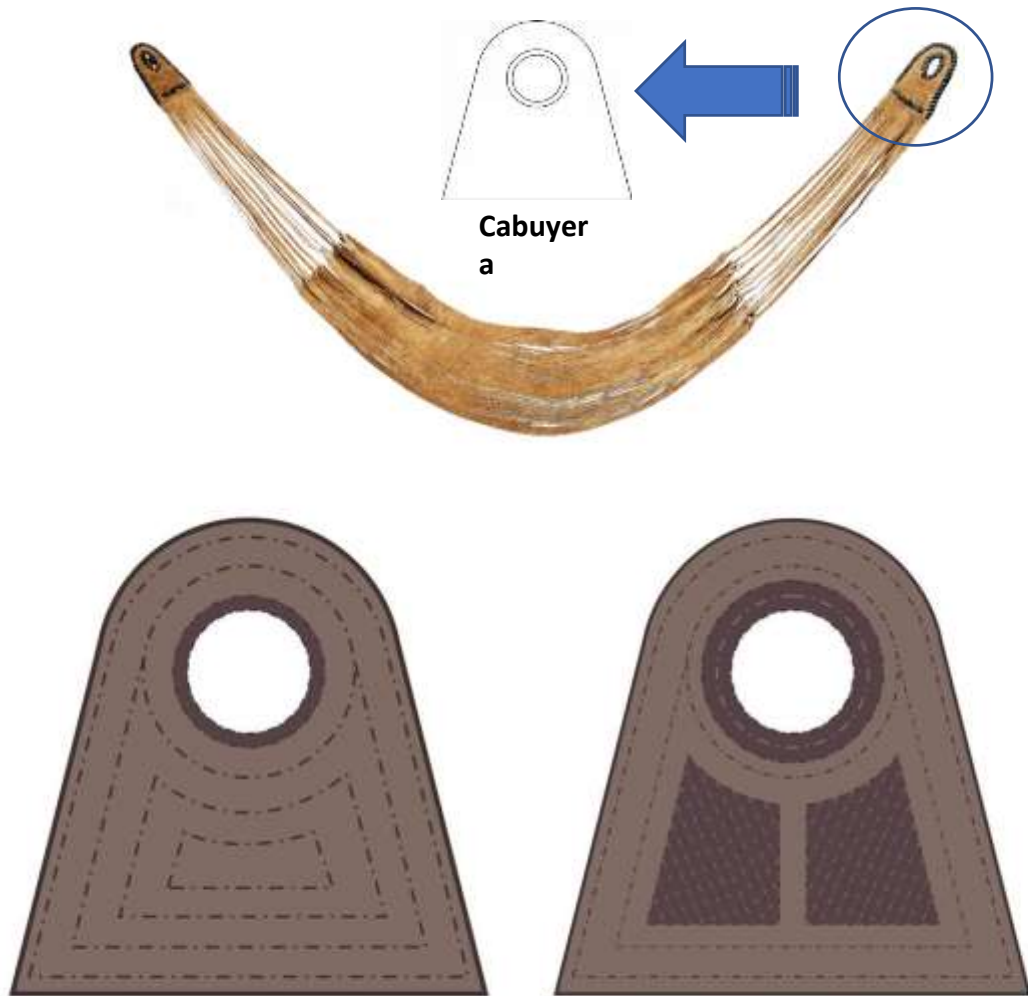

**REFERENT  
E**

Oficio: Marroquinería

Técnica: Cosido, calado, repujado

Materia prima: Cuero

Artesano: Santos Concho – Taller Aquará.

Nombre del producto: Campechana



El progreso  
es de todos

Gobierno  
de Colombia  
Mincomercio



REGIÓN  
ORINOCO

**CASANARE**



El progreso  
es de todos

Gobierno  
de Colombia  
Mincomercio





# GRUPO ARTESANAL MORICHITO

**Municipio:** Hato Corozal

**Etnia:** Saliba.

**Materia prima:** Madera, arcilla.

**Oficio:** Trabajo en madera, alfarería.

**Técnica:** Moldeado, mixtas.

**Número de artesanos:** 40 artesanos.



**NIVEL 1**



El progreso  
es de todos

Gobierno  
de Colombia  
Mincomercio





Referente

Alfarería  
Hato Corozal - Casanare  
Grupo: Morichito  
Resguardo indígena Sálivas  
Moldeado, torneado  
Pintura a mano.  
Diferentes tonalidades tierra (tintes naturales).



Referente

Referente





**REFERENT  
E**

Oficio: Alfarería

Técnica: Moldeado

Materia prima: Arcilla

Artesano: Jose Herrera

Nombre del producto: Maceteros cilindro curvas grandes, maceteros cilindro curvas pequeños.



El progreso  
es de todos

Gobierno  
de Colombia  
Mincomercio





**REFERENT  
E**

Oficio: Alfarería

Técnica: Moldeado

Materia prima: Arcilla

Artesano: Jose Herrera

Nombre del producto: Maceteros esfera grandes,  
maceteros esfera pequeños.



El progreso  
es de todos

Gobierno  
de Colombia  
Mincomercio







**REFERENT  
E**

Oficio: Alfarería

Técnica: Moldeado

Materia prima: Arcilla

Artesano: Jose Herrera

Nombre del producto: Materos Rostros



El progreso  
es de todos

Gobierno  
de Colombia  
Mincomercio



artesanías de colombia



Cucharas en  
madera x 3



REFERENT  
E

Oficio: Alfarería

Técnica: Moldeado

Materia prima: Arcilla

Artesano: Jose Herrera

Nombre del producto: Especieros Set x 3



El progreso  
es de todos

Gobierno  
de Colombia  
Mincomercio



REGIÓN  
ORINOCO

CAQUETÁ



El progreso  
es de todos

Gobierno  
de Colombia  
Mincomercio



EXPEDICIÓN ORINOCO  
RECORRIENDO IDENTIDADES ANCESTRALES



## TALLER CANASTO DE LA ABUNDANCIA MONILLA QUIRIGAI – NIGA

**Municipio:** Solano – Resguardo Indígena Ismuina

**Etnia:** Muina murui /Uitoto

**Materia prima:** Yaré, guarumo, cumare

**Oficio:** Certería

**Técnica :**

**Número de artesanos:** 13

Comunicaciones: B

Nivel del grupo: 2

Atención: *Diseño, desarrollo humano, comercial*



El progreso  
es de todos

Gobierno  
de Colombia  
Mincomercio



EXPEDICIÓN ORINOCO  
RECORRIENDO IDENTIDADES ANCESTRALES



## CANASTOS NARE – GESTACIÓN

Municipio: Solano

Etnia: Murui muina

Materia prima: Cumare, yaré, guaruma

Técnica: Sarga

Artesano: Tatiana O

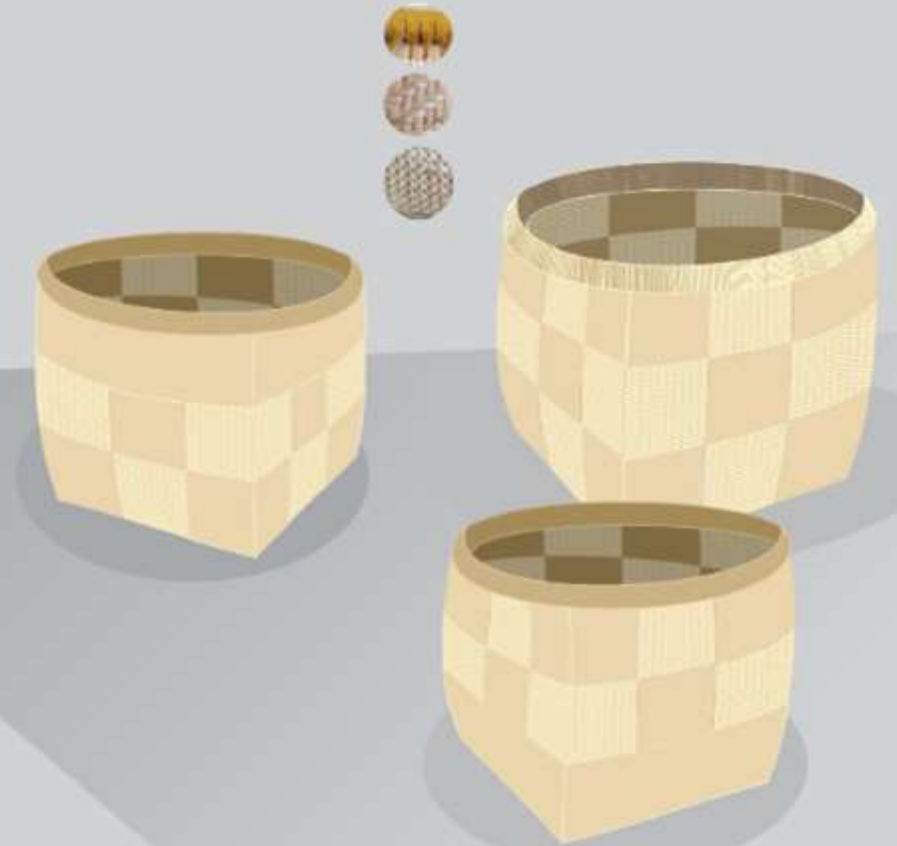
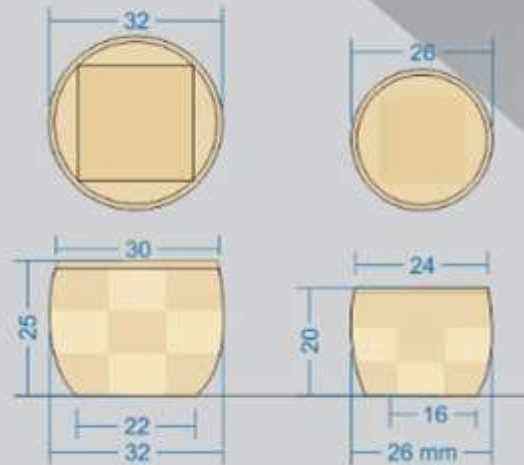



## ARTESANÍAS COREGUAJE PAIREPA

**Municipio:** Milán – Corregimiento San Antonio Jetucha.

**Etnia:** Koreguaje

**Materia prima:** Cumare, semillas

**Oficio:** Tejeduría, cestería, bisutería

**Técnica :** Tejido de punto, crochet, ensartado

**Número de artesanos:** 16

Comunicaciones: B

Nivel del grupo: *Pendiente*

*Atención: Pendiente*



El progreso  
es de todos

Gobierno  
de Colombia  
Mincomercio



EXPEDICIÓN ORINOCO  
RECORRIENDO IDENTIDADES ANCESTRALES



## MORRAL – MUNDOS K

Municipio: Milán

Etnia: Koreguaje

Materia prima: Cumare

Técnica:

Artesano: Leonidas G

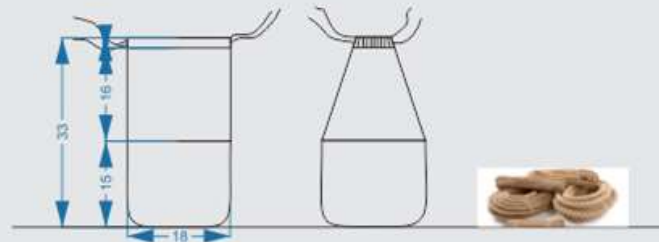



## CONTENEDORES – CUSMA

### Set – closet, tocador

Municipio: Milán

Etnia: Koreguaje

Materia prima: Cumare

Técnica:

Artesano: Leonidas G

Diseñador: Aida Perugache R

Concepto en comité:

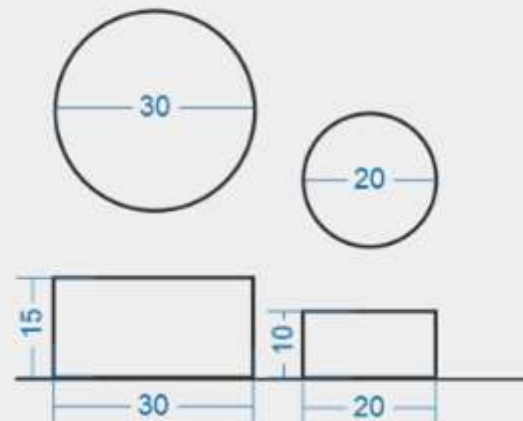



REGIÓN  
ORINOCO

GUAINÍA



El progreso  
es de todos

Gobierno  
de Colombia  
Mincomercio



EXPEDICIÓN ORINOCO  
RECORRIENDO IDENTIDADES ANCESTRALES



## MUJERES BARRIO PORVENIR

**Municipio:** Inírida

**Etnia:** Curripaco, cubeo.

**Materia prima:** Chiqui chiqui – yaré

**Oficio:** Cestería

**Técnica :** Rollo

**Número de artesanos:** 20

Comunicaciones: B

Nivel del grupo: 1

*Atención: Diseño, desarrollo humano*



El progreso  
es de todos

Gobierno  
de Colombia  
Mincomercio



EXPEDICIÓN ORINOCO  
RECORRIENDO IDENTIDADES ANCESTRALES



### Línea mesa - Esencia Kurripaca

Municipio: Inírida  
Etnia: Cubeo - Kurripaco  
Materia prima: Chiqui chiqui  
Técnica: Rollo  
Artesana: Grupo

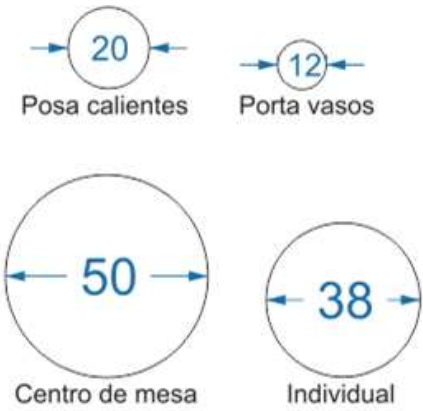

Avance de la muestra - fotografía enviada por las artesanas



### Línea mesa - Esencia Intercultural

Municipio: Inírida  
Etnia: Cubeo - Kurripaco  
Materia prima: yaré - Chiqui chiqui  
Técnica: Rollo  
Artesana: Grupo



Remate individual y centro de mesa

Foto de avance enviada por las artesanas.



### Línea mesa - Contenedor

Municipio: Inírida  
Etnia: Cubeo - Kurripaco  
Materia prima: yaré - Chiqui chiqui  
Técnica: Rollo  
Artesana: Grupo



Rescate - Integración de materias primas y técnicas cubeo y Kurripaco

Foto de muestra enviada por las artesanas.

REGIÓN  
AMAZONAS

VAUPÉS



El progreso  
es de todos

Gobierno  
de Colombia  
Mincomercio



EXPEDICIÓN ORINOCO  
RECORRIENDO IDENTIDADES ANCESTRALES



## GRUPO CERÁMICAS ÉTNICAS CUBAY

**Municipio:** Mitú

**Etnia:** Cubeo

**Materia prima:** Arcilla, madera

**Oficio:** Alfarería, talla en madera

**Técnica :** Armado en rollo , talla

**Número de artesanos:** 7

Comunicaciones: B

Nivel del grupo: 2

Atención: *Diseño, desarrollo humano*



El progreso  
es de todos

Gobierno  
de Colombia  
Mincomercio



EXPEDICIÓN ORINOCO  
RECORRIENDO IDENTIDADES ANCESTRALES



## Set materas – Constelaciones de Piracemo (X2)

Municipio: Mitú

Etnia: Cubeo

Materia prima: Arcilla - guarumá

Técnica: Rollo

Artesano: Lucía Ch. – Rodrigo L







## Contenedores - Universo

Municipio: Mitú

Etnia: Cubeo

Materia prima: Arcilla

Técnica: Rollo

Artesano: Lucía Ch. – Rodrigo L

Diseñador: Aida Perugache R

Concepto en comité:

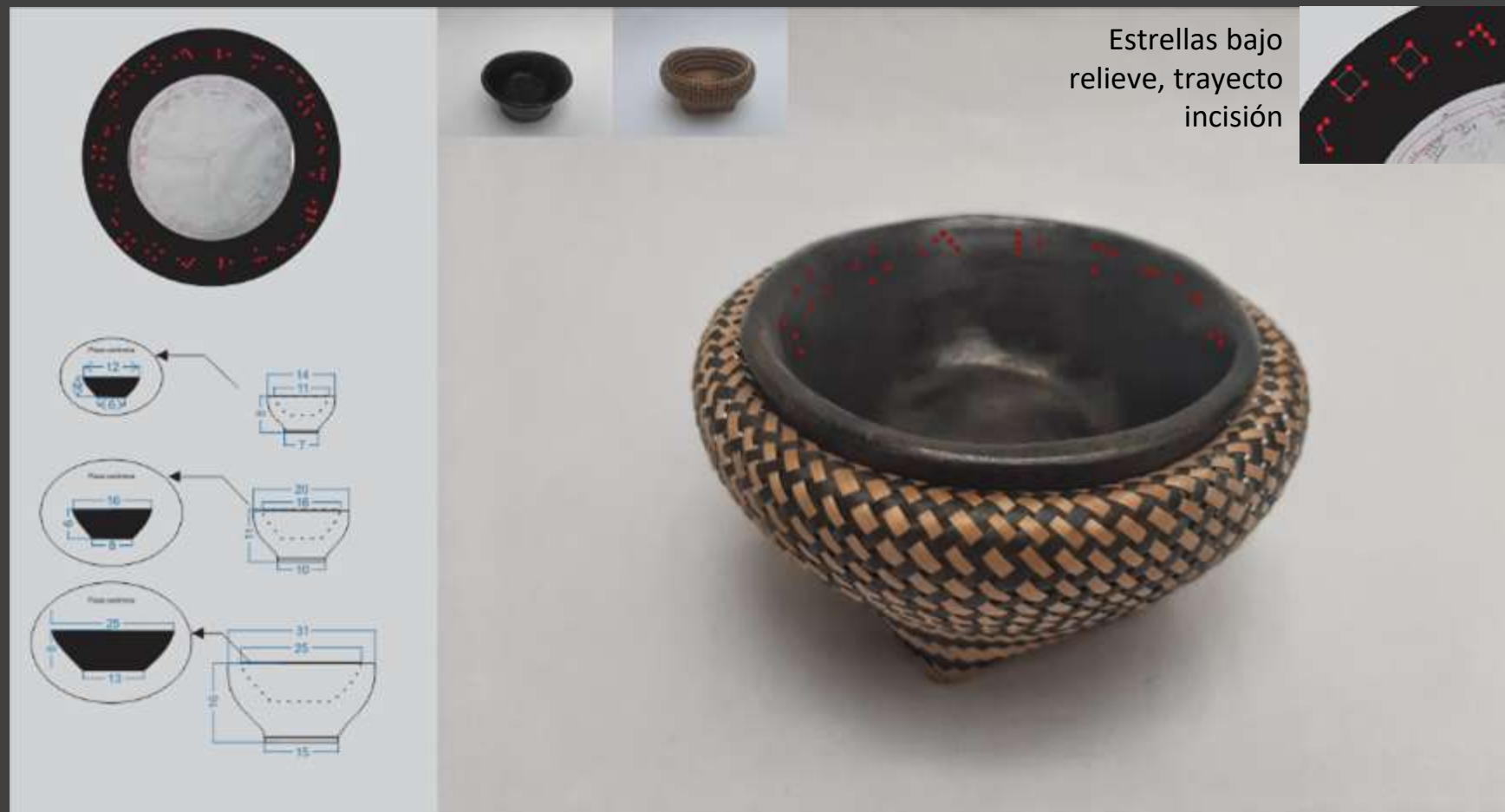



## CERÁMICAS CUBAY JEJENAVA

**Municipio:** Mitú

**Etnia:** Cubeo

**Materia prima:** Arcilla-barro azul

**Oficio:** Alfarería

**Técnica :** Armado en rollo –

**Número de artesanos:** 9

Comunicaciones: B

Nivel del grupo: 2

*Atención: Diseño, desarrollo humano*



El progreso  
es de todos

Gobierno  
de Colombia  
Mincomercio



EXPEDICIÓN ORINOCO  
RECORRIENDO IDENTIDADES ANCESTRALES



## Set especieros – Pareja de Dancistas 1

Municipio: Mitú

Etnia: Cubeo

Materia prima: Arcilla

Técnica: Rollo

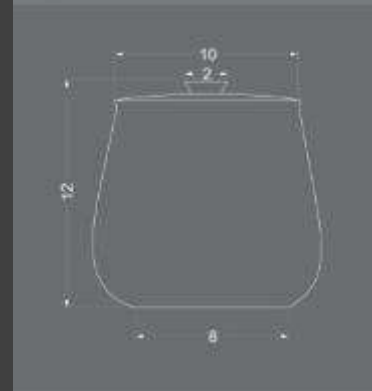



## Set de Ollas: Molinillo

Municipio: Mitú

Etnia: Cubeo

Materia prima: Arcilla

Técnica: Rollo

Diseñador: Aida Perugache R

Concepto en comité:

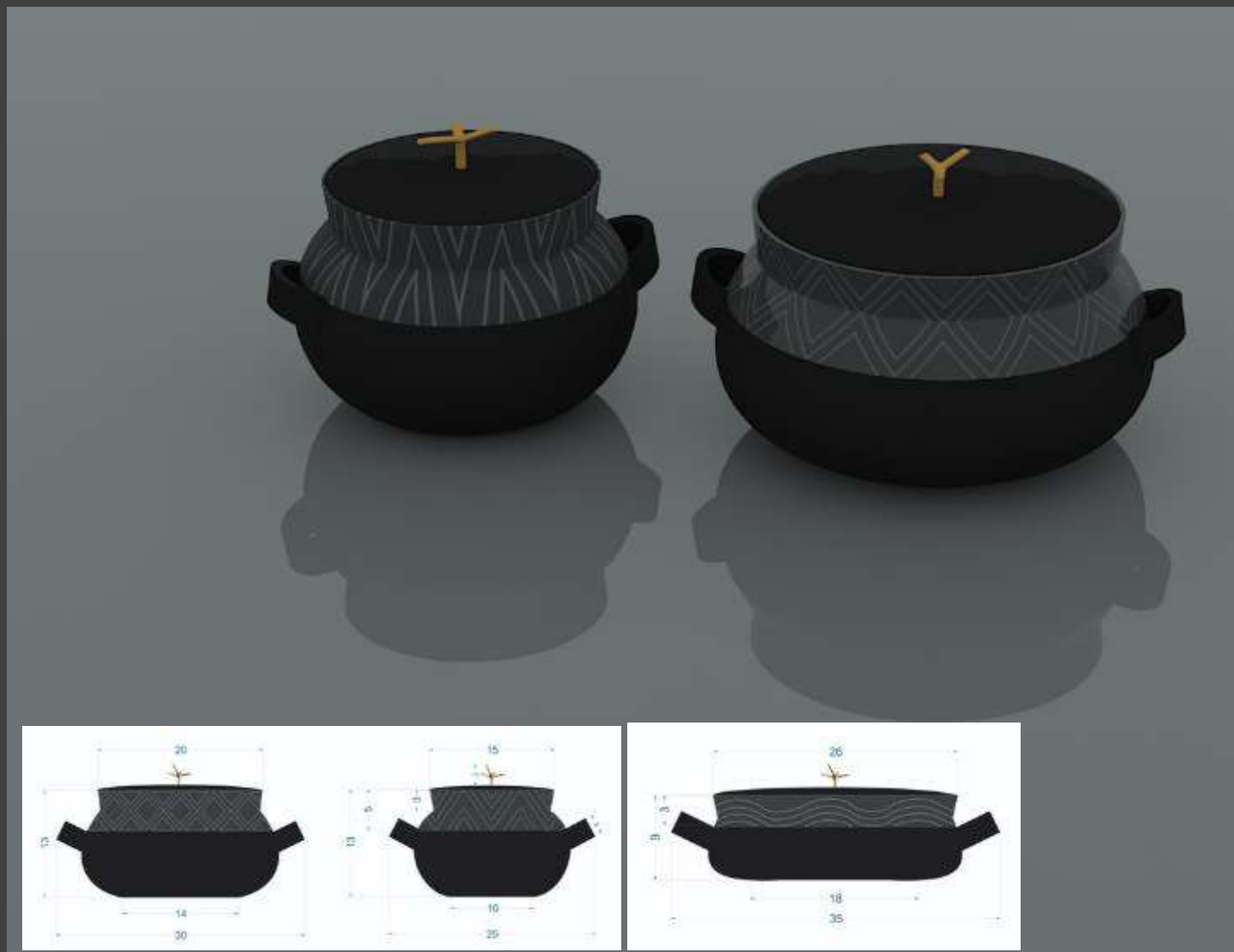



## Tinaja Yagé

Municipio: Mitú

Etnia: Cubeo

Materia prima: Arcilla

Técnica: Rollo





## GRUPO ARTESANOS DE PUERTO TOLIMA QUERARÍ

**Municipio:** Mitú

**Etnia:** Cubeo

**Materia prima:** Guaruma - yaré

**Oficio:** Cestería

**Técnica :**

**Número de artesanos:** 3 (Mitú) 22 comunidad

Comunicaciones: B (3)

Nivel del grupo: 2

*Atención: Diseño, desarrollo humano*



El progreso  
es de todos

Gobierno  
de Colombia  
Mincomercio



EXPEDICIÓN ORINOCO  
RECORRIENDO IDENTIDADES ANCESTRALES



## Canastos Chagra

Municipio: Mitú

Etnia: Cubeo

Materia prima: Yaré

Técnica: sarga

*"Cada pedacito representa la chagra de cada una de las mujeres"*





## Porta chips Casabe

Municipio: Mitú

Etnia: Cubeo

Materia prima: Guaruma

Técnica: Sarga

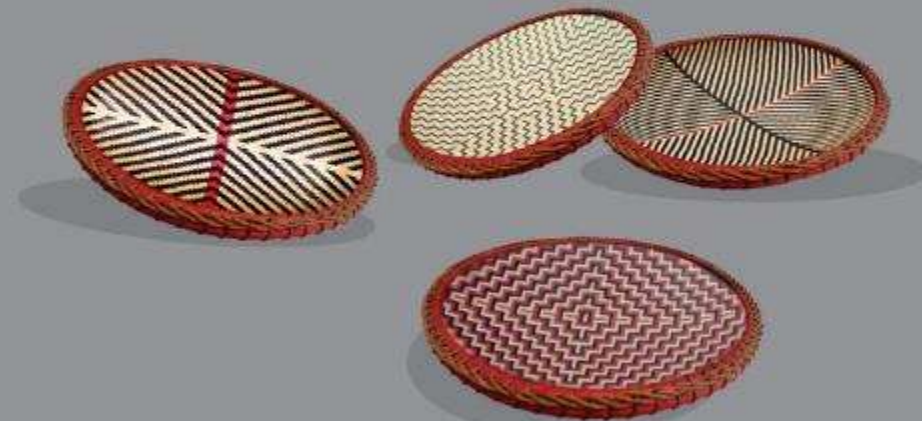



---

“PIENSA BONITO,  
HABLA BONITO,  
TEJE BONITO...”

---

Hugo Jamioy, etnia Kamëntsá

¡GRACIAS!



El progreso  
es de todos

Gobierno  
de Colombia  
Mincomercio



EXPEDICIÓN ORINOCO  
RECORRIENDO IDENTIDADES ANCESTRALES