

artesanías
de colombia



EXPEDICIÓN ORINOCO

RECORRIENDO IDENTIDADES ANCESTRALES

PROPUESTAS DE DISEÑO DEPARTAMENTO DEL CAQUETÁ

2020



EXPEDICIÓN ORINOCO
RECORRIENDO IDENTIDADES ANCESTRALES



El progreso
es de todos

Gobierno
de Colombia
Mincomercio



REGIÓN
ORINOQUÍA

CAQUETÁ

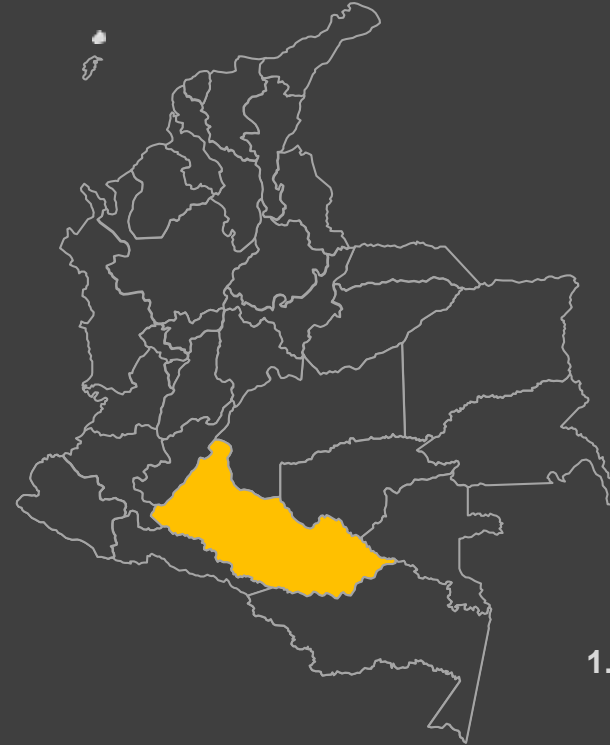

1. CANASTO DE LA ABUNDANCIA
PAIPAREPA – NIGA
2. TALLER ARTESANAL
COREGUAJE PAIREPA



El progreso
es de todos

Gobierno
de Colombia
Mincomercio





“COSMOVISIÓN
KOREGUAJE”

TALLER ARTESANAL
KOREGUAJE
PAIREPA

MILÁN

PROPUESTAS DE DISEÑO

Fotografía: Tomada del catálogo de los artesanos
2017



MORRAL – MUNDOS K

Municipio: Milán

Etnia: Koreguaje

Materia prima: Cumare

Técnica:

Artesano: Leonidas G

Diseñador: Aida Perugache R

Concepto en comité:

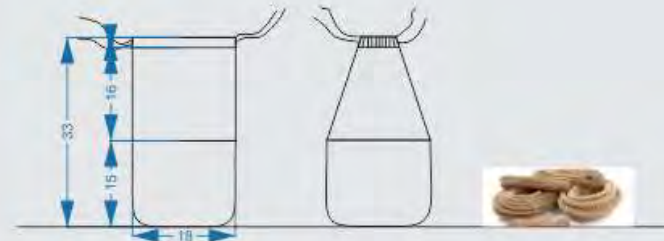



MORRAL – MUNDOS K

Municipio: Milán

Etnia: Koreguaje

Materia prima: Cumare

Técnica:

Artesano: Leonidas G

Diseñador: Aida Perugache R

Concepto en comité:





MOCHILA MANO – CHIACHIA

Municipio: Milán

Etnia: Koreguaje

Materia prima: Cumare

Técnica:

Artesano: Leonidas G

Diseñador: Aida Perugache R

Concepto en comité:

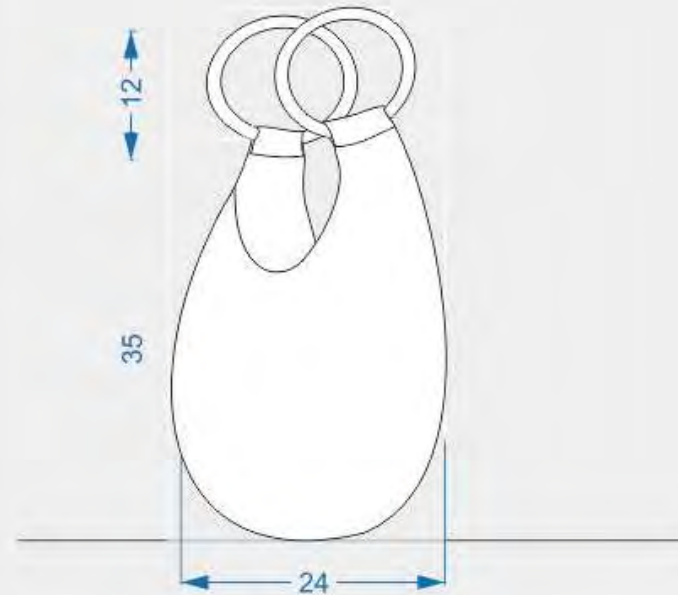



MOCHILA MANO – CHIACHIA

Municipio: Milán

Etnia: Koreguaje

Materia prima: Cumare

Técnica:

Artesano: Leonidas G

Diseñador: Aida Perugache R

Concepto en comité:





CONTENEDORES – CUSMA

Set – closet, tocador

Municipio: Milán

Etnia: Koreguaje

Materia prima: Cumare

Técnica:

Artesano: Leonidas G

Diseñador: Aida Perugache R

Concepto en comité:

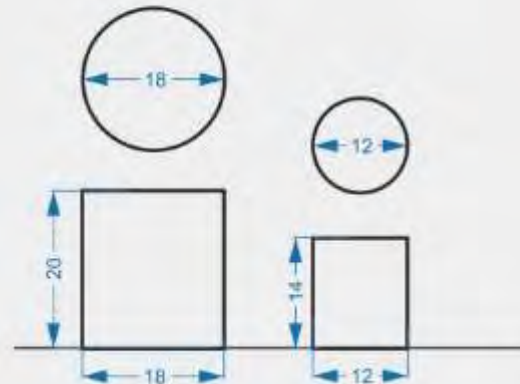



CONTENEDORES – CUSMA

Set – closet, tocador

Municipio: Milán

Etnia: Koreguaje

Materia prima: Cumare

Técnica:

Artesano: Leonidas G

Diseñador: Aida Perugache R

Concepto en comité:

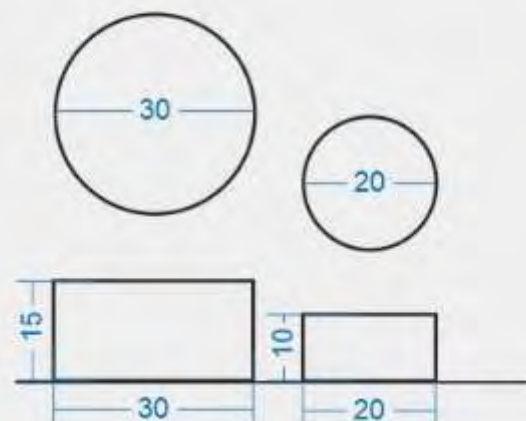



CONTENEDORES – CUSMA Set – closet, tocador

Municipio: Milán

Etnia: Koreguaje

Materia prima: Cumare

Técnica:

Artesano: Leonidas G

Diseñador: Aida Perugache R

Concepto en comité:

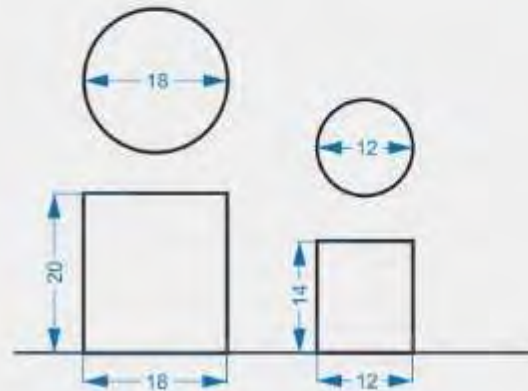



“SABIDURÍA
MÚRUI”

CANASTO DE LA
ABUNDANCIA
NIGA

SOLANO

Fotografía: Tomada del catálogo de los artesanos
2017



CANASTOS NARE – GESTACIÓN

Municipio: Solano

Etnia: Murui muina

Materia prima: Cumare, yaré, guaruma

Técnica: Sarga

Artesano: Tatiana O

Diseñador: Aida Perugache R

Concepto en comité:

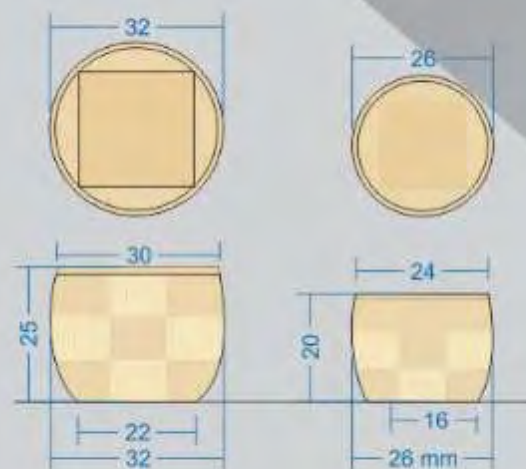



CANASTOS NARE – GESTACIÓN

Municipio: Solano

Etnia: Murui muina

Materia prima: Cumare, yaré, guaruma

Técnica: Sarga

Artesano: Tatiana O

Diseñador: Aida Perugache R

Concepto en comité:

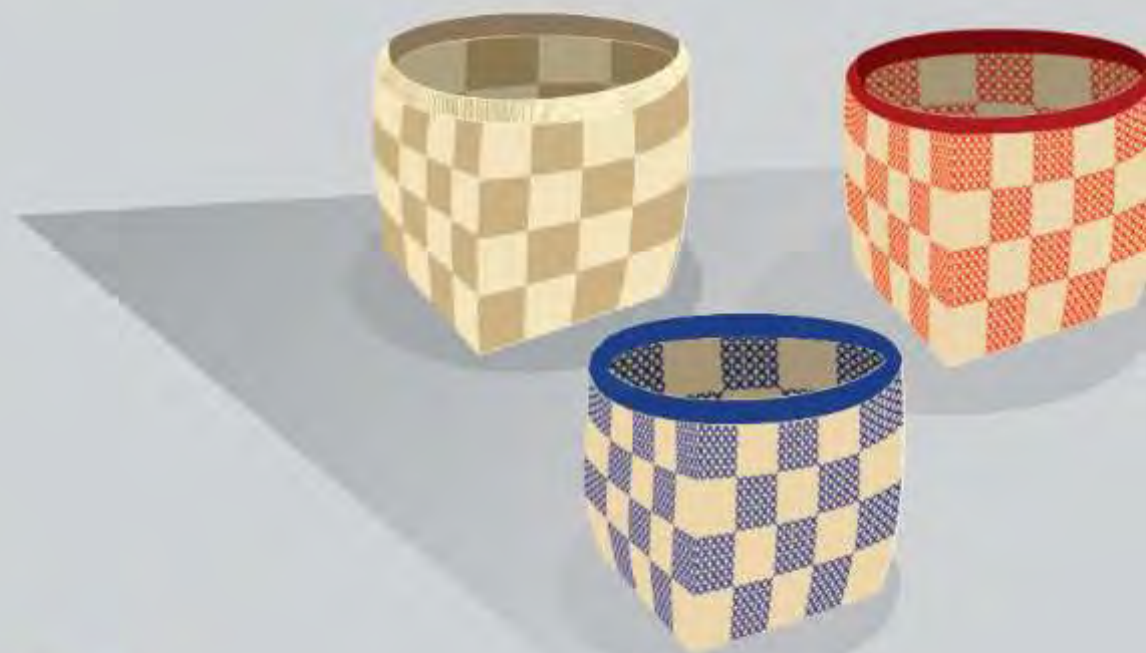



CANASTOS MESA – INICIACIÓN

Municipio: Solano

Etnia: Murui muiname

Materia prima: Cumare, yaré, guaruma

Técnica:

Artesano: Tatiana O

Diseñador: Aida Perugache R

Concepto en comité:

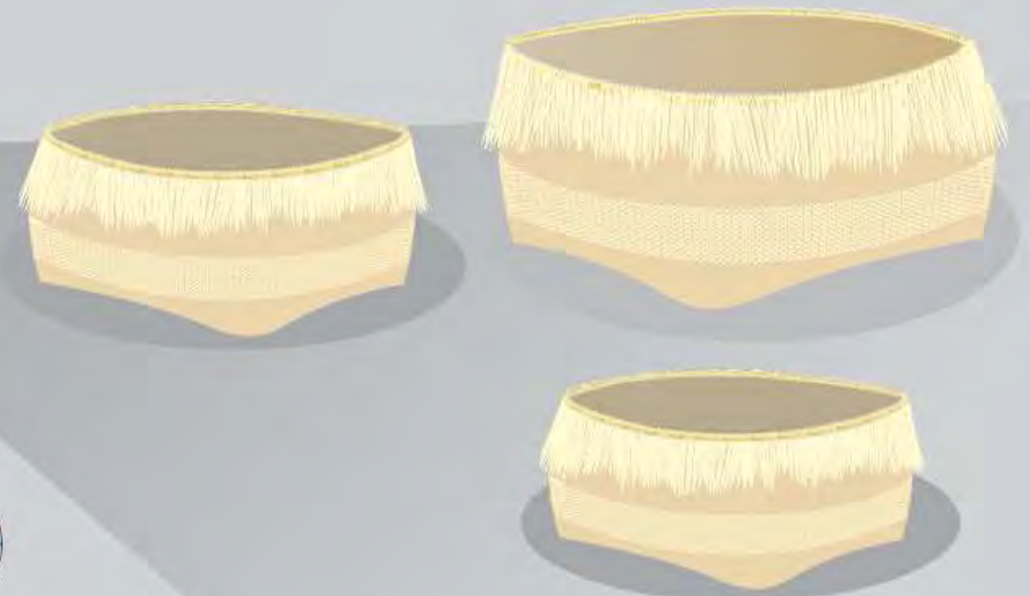
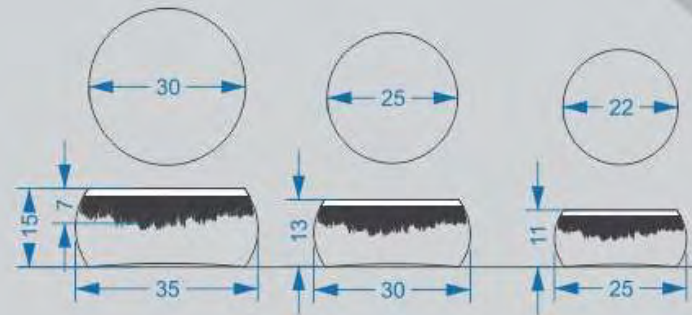



CANASTOS MESA – INICIACIÓN 2

Municipio: Solano

Etnia: Murui muiname

Materia prima: Cumare, yaré, guaruma

Técnica:

Artesano: Tatiana O

Diseñador: Aida Perugache R

Concepto en comité:

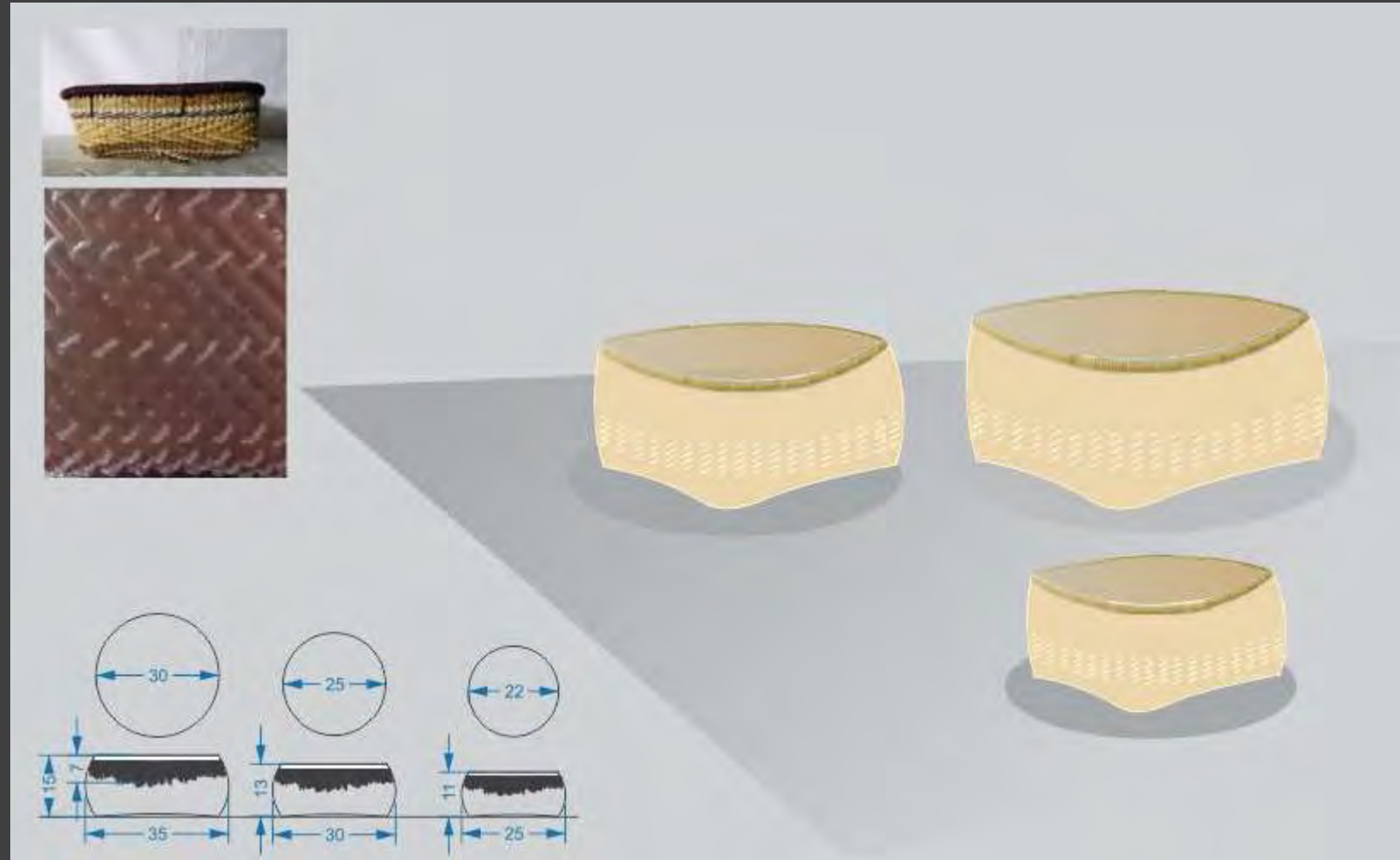



CANASTOS MALOCA

Municipio: Solano

Etnia: Murui muiname

Materia prima: Cumare, yaré, guaruma

Técnica:

Artesano: Tatiana O

Diseñador: Aida Perugache R

Concepto en comité:





CANASTOS MALOCA

Municipio: Solano

Etnia: Murui muiname

Materia prima: Cumare, yaré, guaruma

Técnica:

Artesano: Tatiana O

Diseñador: Aida Perugache R

Concepto en comité:

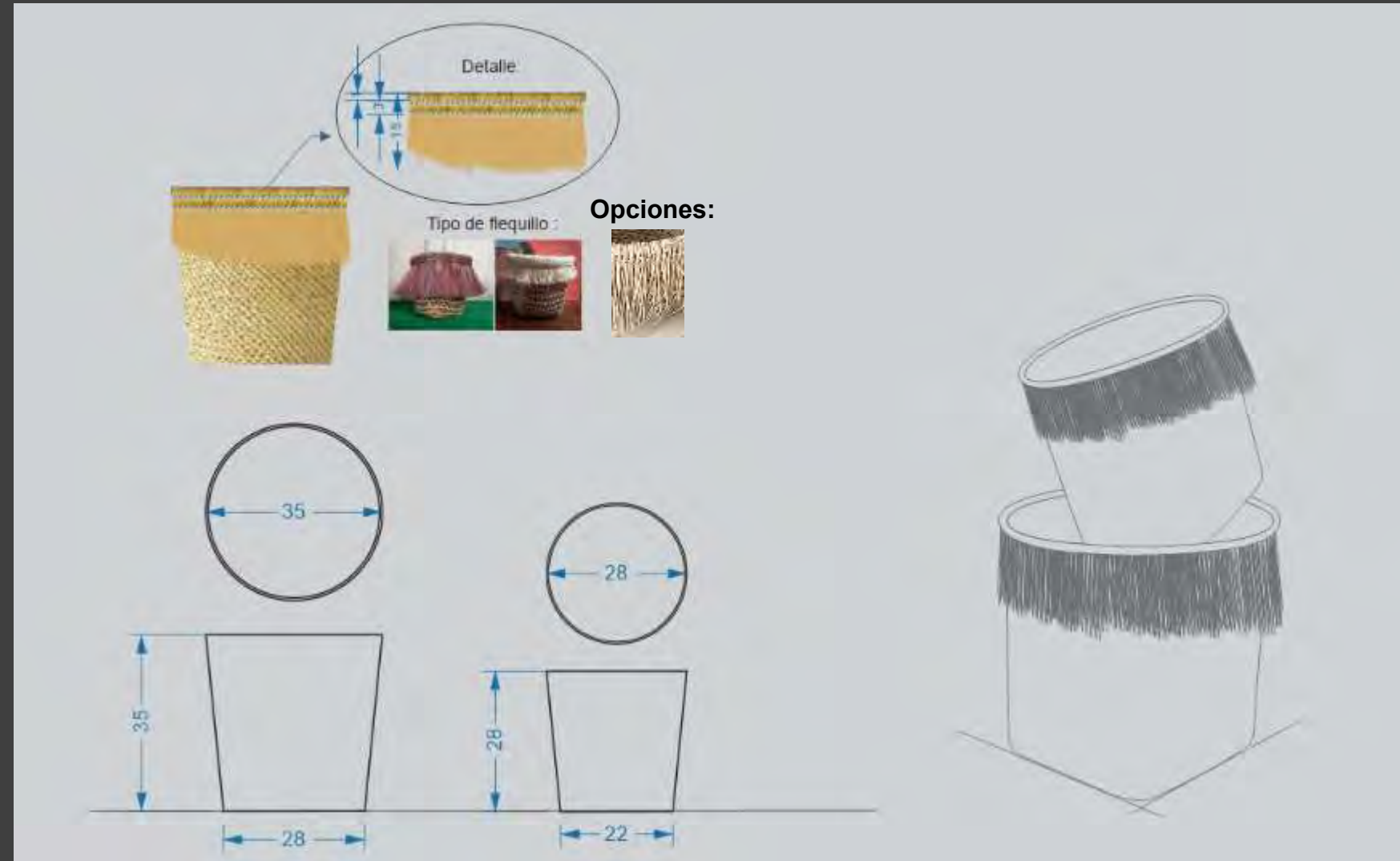

“PIENSA BONITO,
HABLA BONITO,
TEJE BONITO...”

Hugo Jamioy, etnia Kamëntsá

