

MUESTRAS PROBETA

SUBGERENCIA DE DESARROLLO



PROYECTO SECRETARIA DE LA MUJER Y EQUIDAD
DE GENERO CUNDINAMARCA 2018

MUESTRAS DE TEJIDOS EN DOS AGUJAS



GOBIERNO
DE COLOMBIA



MINCIT



artesanías de colombia



SEC MUJER
Y EQUIDAD DE GÉNERO
GOBERNACIÓN DE CUNDINAMARCA



CUNDINAMARCA
unidos podemos más



CUNDINAMARCA
"EL DORADO"
"LA LEYENDA VIVE!"

INICIO DE TEJIDO



Sostener en la mano izquierda la aguja con los puntos (p.) montados y el hilo suelto que sigue unido a la madeja hacia atrás del trabajo. Insertar la aguja de la mano derecha desde la izquierda a la derecha por el frente del primer punto (p.) en la aguja de la mano izquierda



GOBIERNO
DE COLOMBIA



MINCIT



artesanías de Colombia



SEC MUJER
Y EQUIDAD DE GÉNERO
GOBERNACIÓN DE CUNDINAMARCA



CUNDINAMARCA
unidos podemos más



CUNDINAMARCA
"EL DORADO"
"LA LEYENDA VIVE"

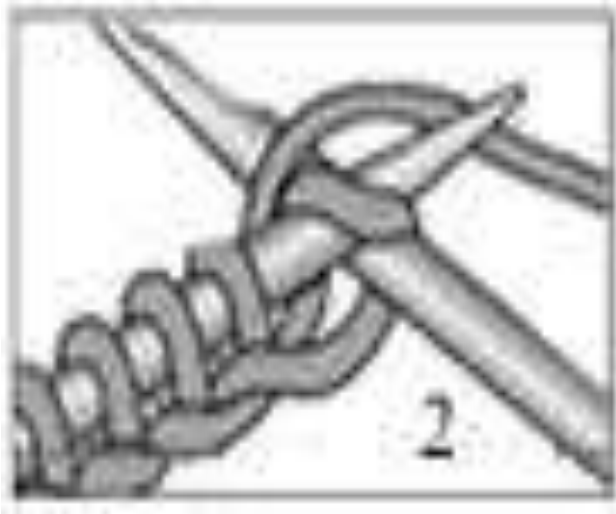

Pasar el hilo desde la izquierda a la derecha hasta la punta de la aguja de la mano derecha.



GOBIERNO
DE COLOMBIA



MINCIT



artesanías de Colombia



SEC MUJER
Y EQUIDAD DE GÉNERO
GOBERNACIÓN DE CUNDINAMARCA



CUNDINAMARCA
unidos podemos más



CUNDINAMARCA
"EL DORADO"
"LA LEYENDA VIVE"

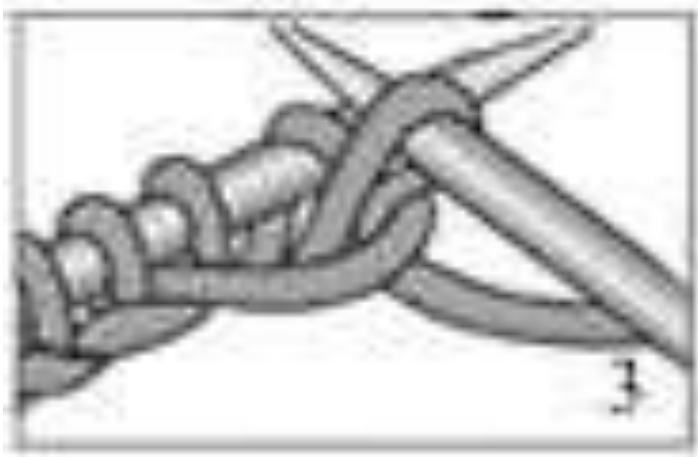

Llevar el hilo a través de este punto (p.) original que forma un nuevo punto (p.) en la aguja de la mano derecha.



GOBIERNO DE COLOMBIA



MINCIT



artesanías de Colombia



SEC MUJER Y EQUIDAD DE GÉNERO
GOBERNACIÓN DE CUNDINAMARCA



CUNDINAMARCA
unidos podemos más



CUNDINAMARCA
"EL DORADO"
"LA LEYENDA VIVE"



Deslizar el punto (p.) original fuera de la aguja de la mano izquierda, manteniendo el nuevo punto (p.) en la aguja de la mano derecha.



GOBIERNO
DE COLOMBIA



MINCIT



artesanías de Colombia



SEC MUJER
Y EQUIDAD DE GÉNERO
GOBERNACIÓN DE CUNDINAMARCA



CUNDINAMARCA
unidos podemos más



CUNDINAMARCA
"EL DORADO"
"LA LEGENDA VIVE"

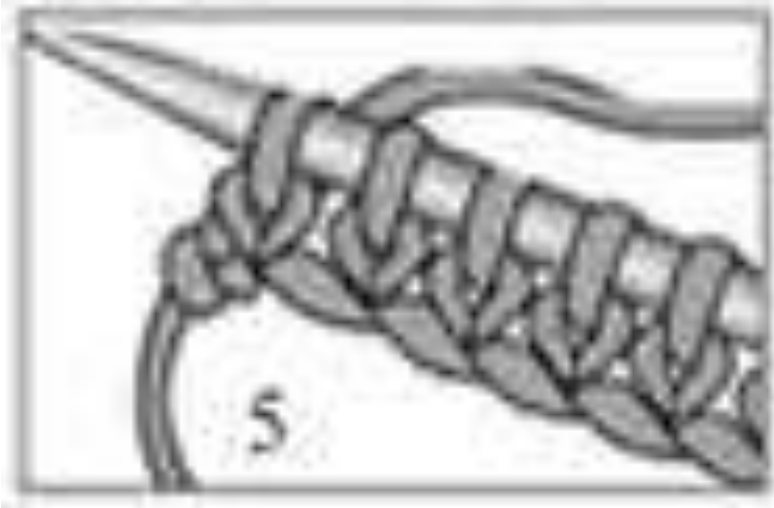

Para tejer una vuelta en derecho, repetir los pasos 1 a 4 hasta haber pasado todos los puntos (p.) desde la aguja de la mano izquierda a la de la mano derecha. Voltear el trabajo colocando la aguja con los puntos (p.) en la mano izquierda para tejer la próxima vuelta en derecho.



GOBIERNO
DE COLOMBIA



MINCIT



artesanías de colombia



SEC MUJER
Y EQUIDAD DE GÉNERO
GOBERNACIÓN DE CUNDINAMARCA



CUNDINAMARCA
unidos podemos más



CUNDINAMARCA
"EL DORADO"
"LA LEYENDA VIVE"

Punto Revés

El punto revés se forma con una argolla queda en el frente de la tela formando una textura. Se realiza de la siguiente manera:



Con el hilo al frente del trabajo, insertar la aguja de la mano derecha desde la derecha hacia la izquierda a través del frente del primer punto (p.) en la aguja de la mano izquierda



Pasar el hilo alrededor de la aguja de la mano derecha. Jalar el hilo a través del punto (p.).



Deslizar el punto (p.) original fuera de la aguja. Repetir (Rep.) estos pasos hasta haber transferido todos los puntos (p.) desde la aguja de la mano izquierda hasta la aguja de la mano derecha para completar una vuelta en revés.



GOBIERNO
DE COLOMBIA



MINCIT



artesanías de colombia



SEC MUJER
Y EQUIDAD DE GÉNERO
GOBERNACIÓN DE CUNDINAMARCA



CUNDINAMARCA
unidos podemos más



CUNDINAMARCA
"EL DORADO"
"LA LEYENDA VIVE"

DIFERENTES PUNTADAS

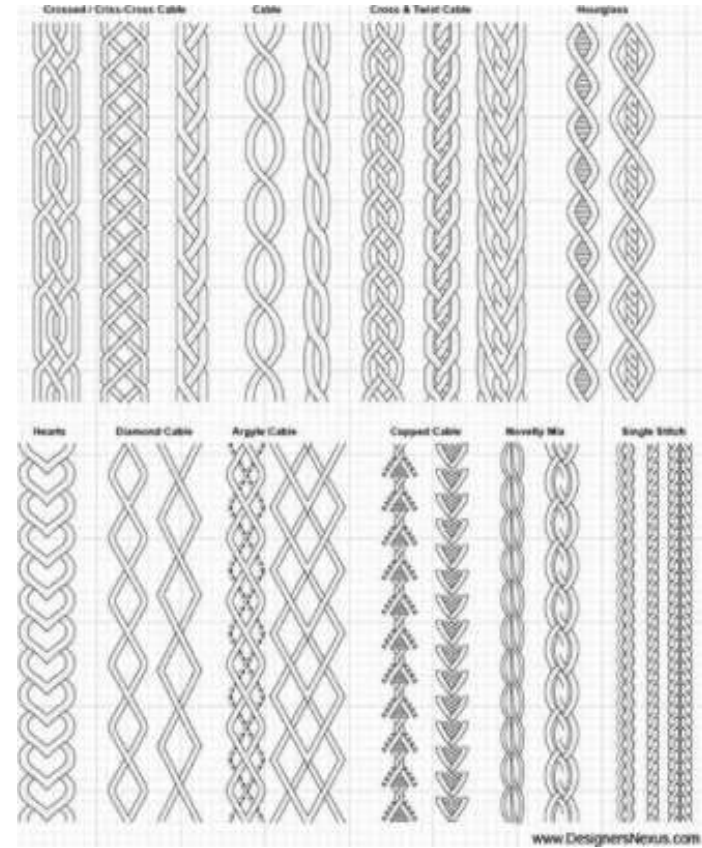
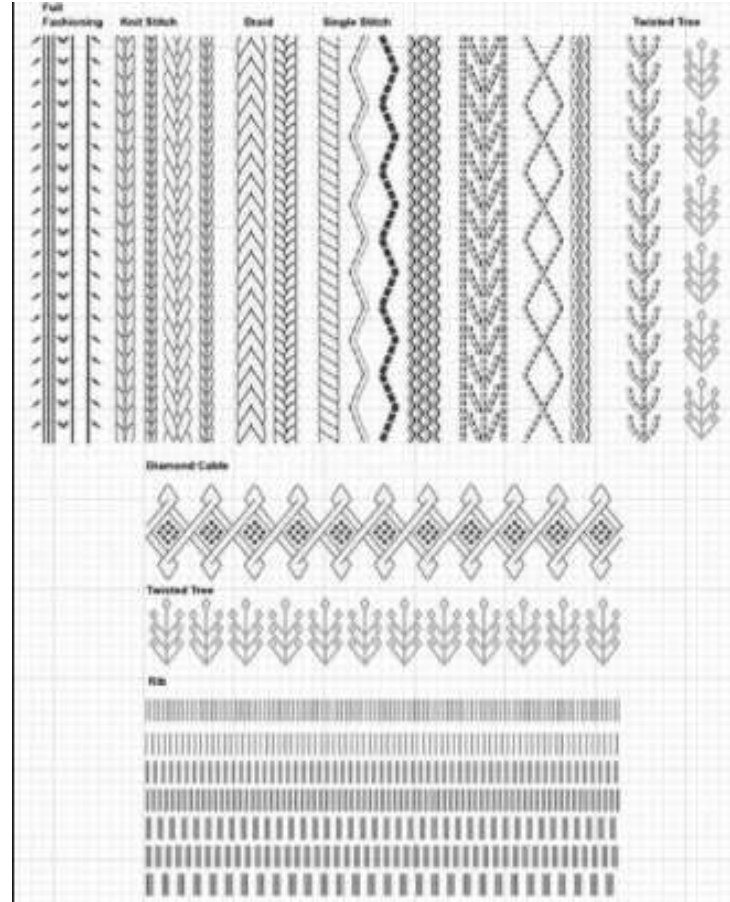



Muestra de Tejido
Material: En Dos Agujas
Tejido:



GOBIERNO
DE COLOMBIA



MINCIT



artesanías de colombia



SEC MUJER
Y EQUIDAD DE GÉNERO
GOBERNACIÓN DE CUNDINAMARCA



CUNDINAMARCA
unidos podemos más



CUNDINAMARCA
"EL DORADO"
"LA LEGENDA VIVE!"



Muestra de Tejido
Material: En Dos Agujas
Tejido: Rombos y Ensortijadas



GOBIERNO
DE COLOMBIA



MINCIT



artesanías de colombia



SEC MUJER
Y EQUIDAD DE GÉNERO
GOBERNACIÓN DE CUNDINAMARCA



CUNDINAMARCA
unidos podemos más



CUNDINAMARCA
"EL DORADO"
"LA LEYENDA VIVE!"

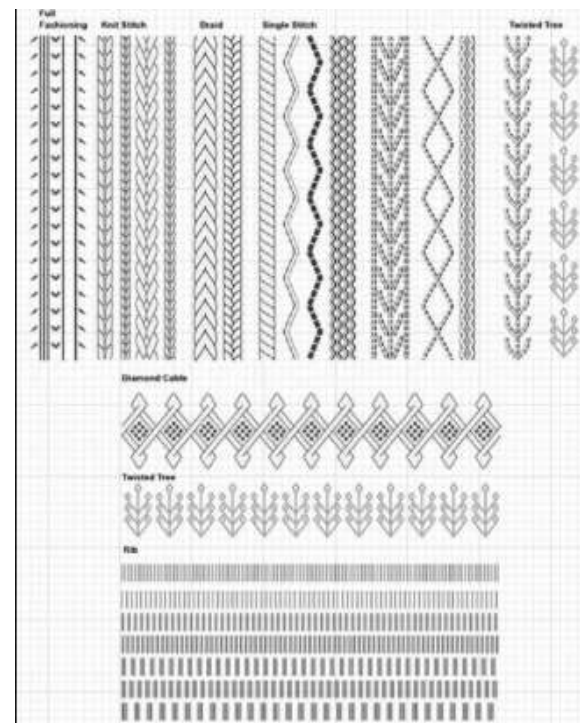

Muestra de Tejido
Material: En Dos Agujas
Tejido: Trenzas



Muestra de Tejido
Material: En Dos Agujas
Tejido: Canastillas



GOBIERNO
DE COLOMBIA



MINCIT



artesanías de colombia



SEC MUJER
Y EQUIDAD DE GÉNERO
GOBERNACIÓN DE CUNDINAMARCA



CUNDINAMARCA
unidos podemos más



CUNDINAMARCA
"EL DORADO"
"LA LEYENDA VIVE"



Muestra de Tejido
Material: En Dos Agujas
Tejido: Trenzas

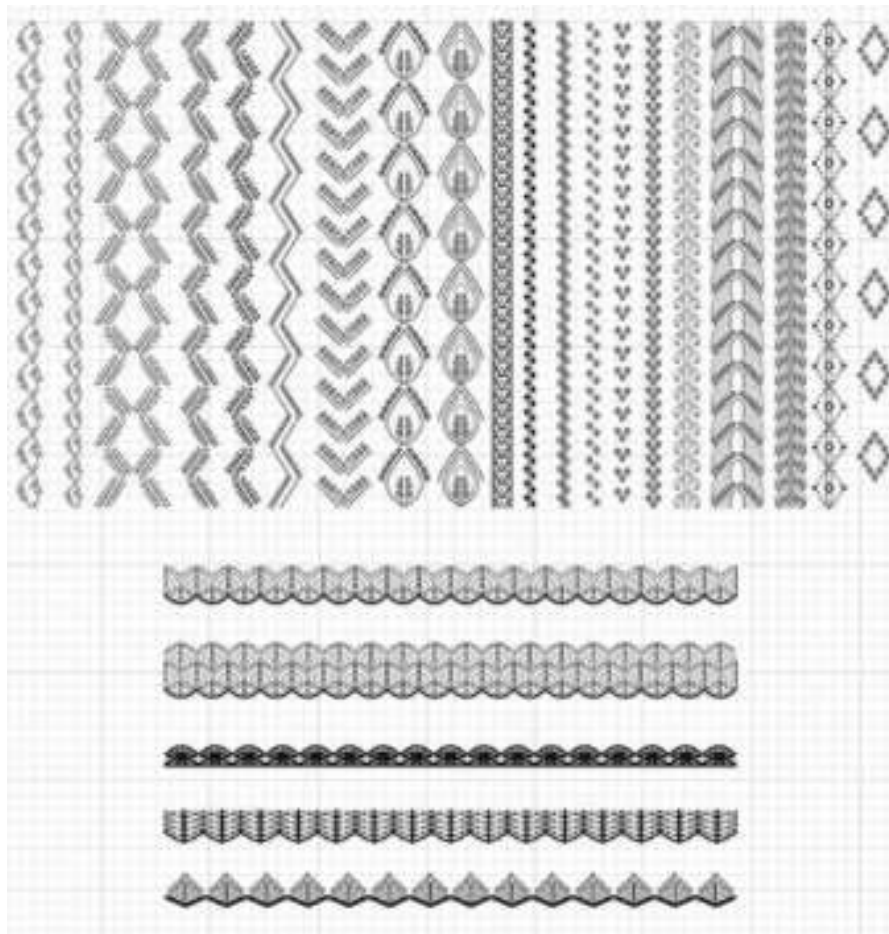

Muestra de Tejido
Material: En Dos Agujas
Tejido: Rombos



GOBIERNO
DE COLOMBIA



MINCIT



artesanías de colombia



SEC MUJER
Y EQUIDAD DE GÉNERO
GOBERNACIÓN DE CUNDINAMARCA



CUNDINAMARCA
unidos podemos más



CUNDINAMARCA
"EL DORADO"
"LA LEGENDA VIVE"

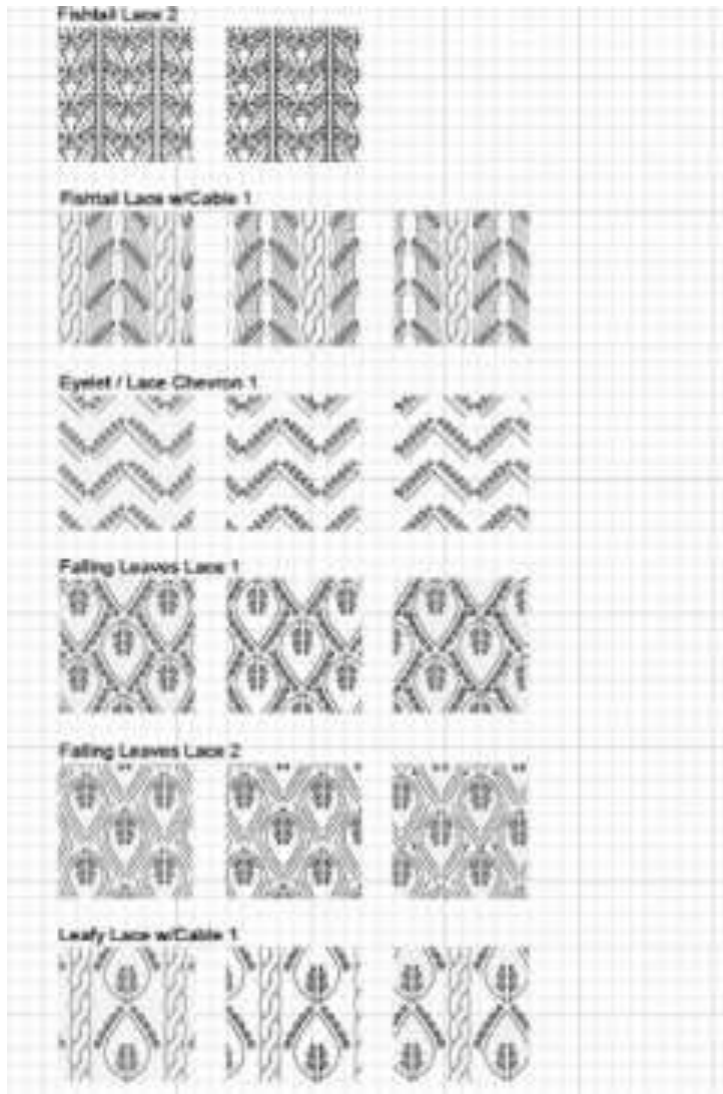

Muestra de Tejido
Material: En Dos Agujas
Tejido: Rombos Tramados



GOBIERNO
DE COLOMBIA



MINCIT



artesanías de colombia



SEC MUJER
Y EQUIDAD DE GÉNERO
GOBERNACIÓN DE CUNDINAMARCA



CUNDINAMARCA
unidos podemos más



CUNDINAMARCA
"EL DORADO"
"LA LEYENDA VIVE"



Muestra de Tejido
Material: En Dos Agujas
Tejido: Jacquard



GOBIERNO
DE COLOMBIA



MINCIT



artesanías de colombia



SEC MUJER
Y EQUIDAD DE GÉNERO
GOBERNACIÓN DE CUNDINAMARCA



CUNDINAMARCA
unidos podemos más



CUNDINAMARCA
"EL DORADO"
"LA LEYENDA VIVE!"



Muestra de Tejido
Material: En Dos Agujas
Tejido: Jacquard

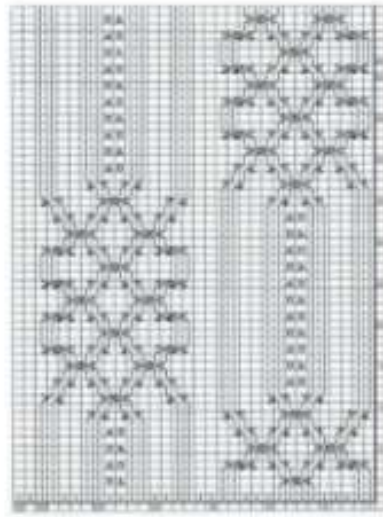

Muestra de Tejido
Material: En Dos Agujas
Tejido: Rombos y Trenzas

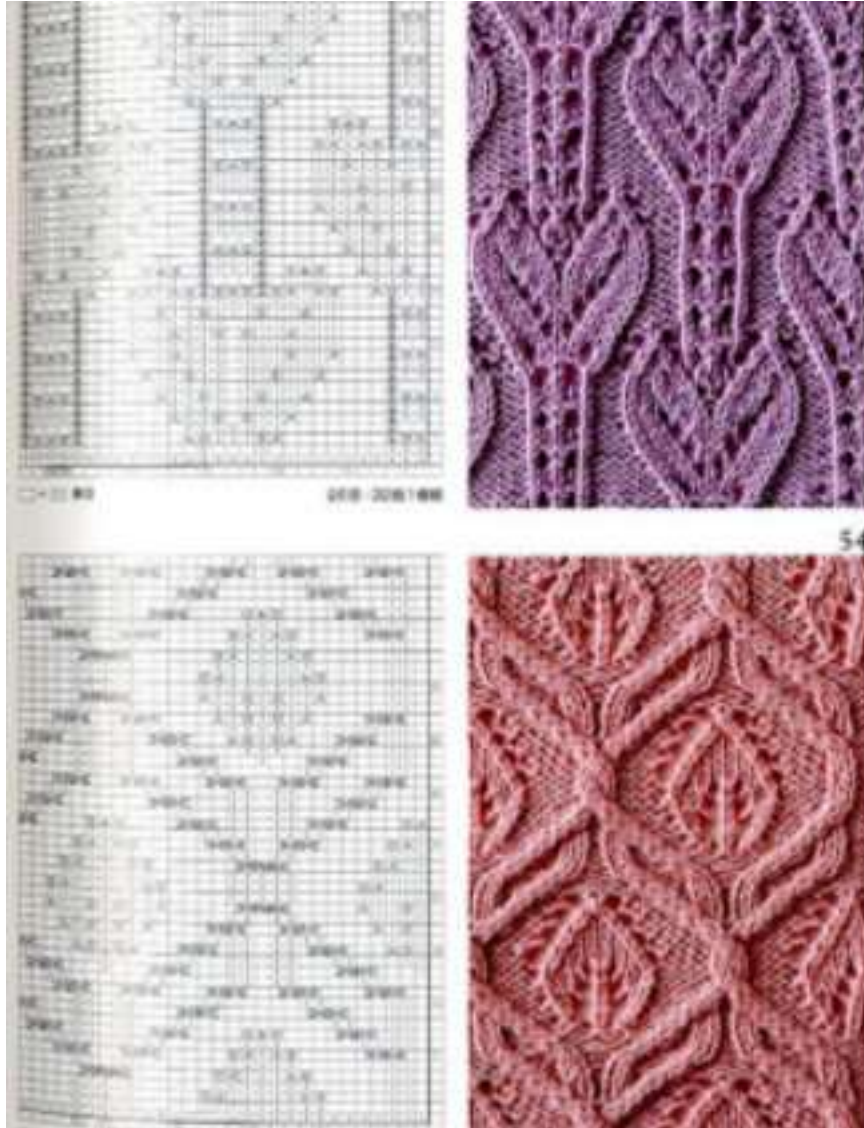

Muestra de Tejido
Material: En Dos Agujas
Tejido: Hojitas

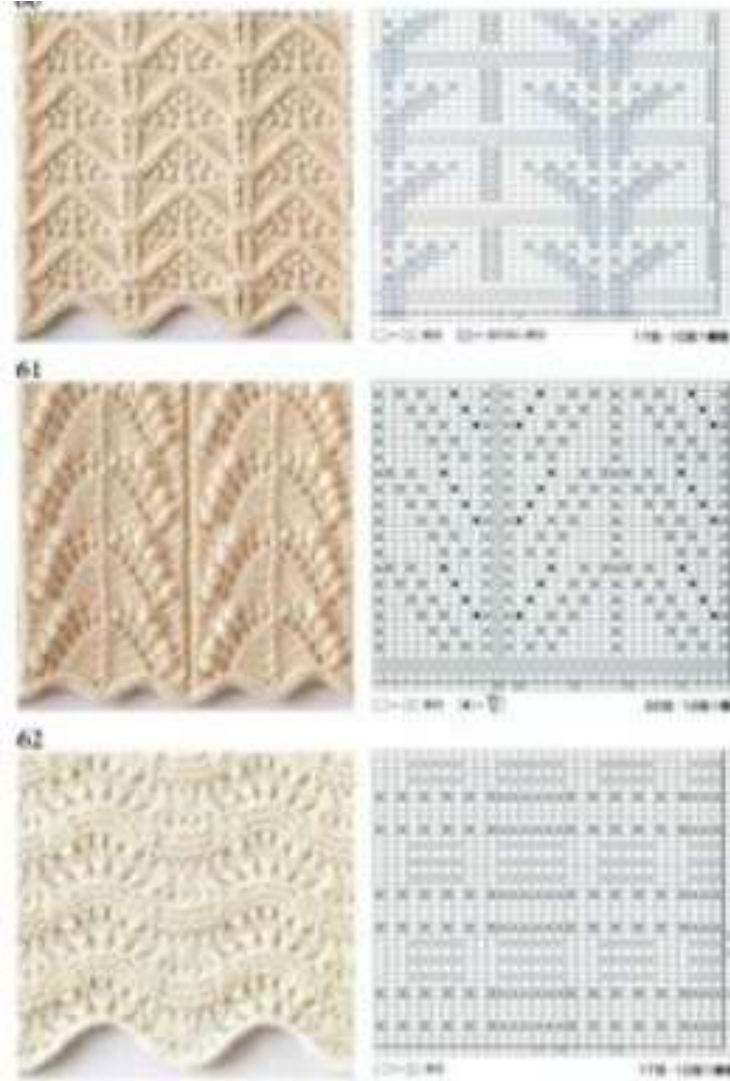

Muestra de Tejido
 Material: En Dos Agujas
 Tejido: Espina y Fantasias

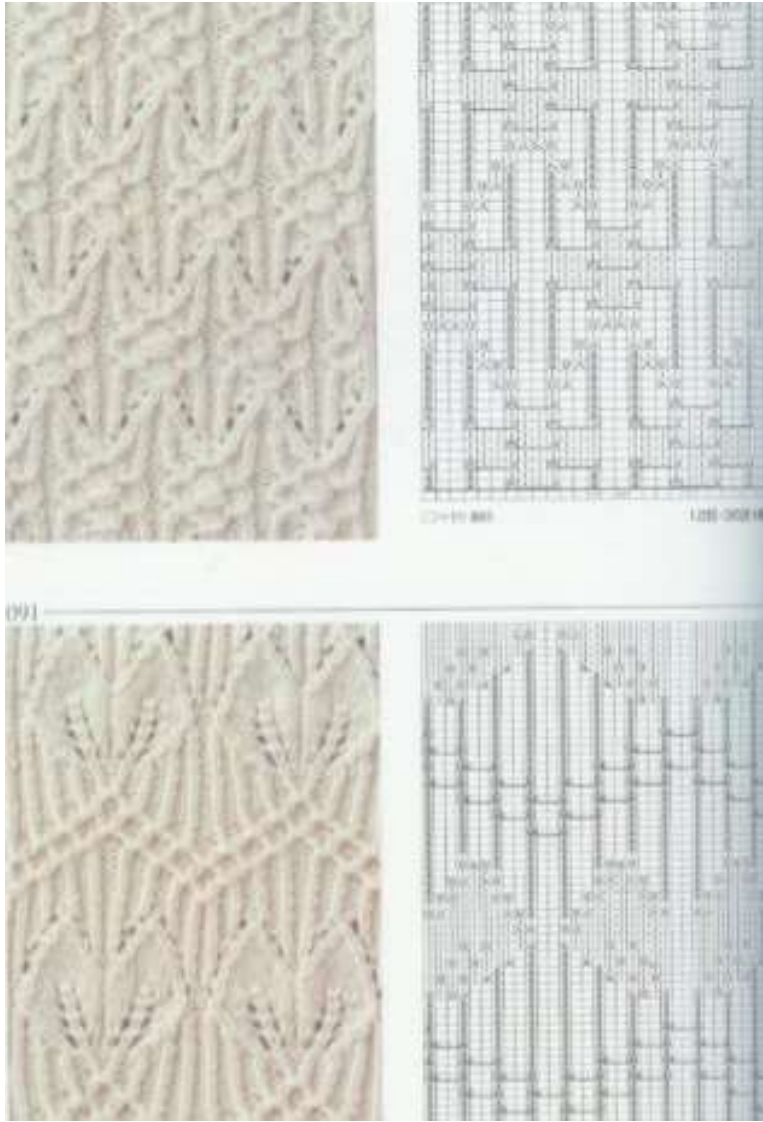

Muestra de Tejido
Material: En Dos Agujas
Tejido: Hojas Y Entrelazados



Muestra de Tejido
Material: En Dos Agujas
Tejido: Canastilla



GOBIERNO
DE COLOMBIA



MINCIT



artesanías de colombia



SEC MUJER
Y EQUIDAD DE GÉNERO
GOBERNACIÓN DE CUNDINAMARCA



CUNDINAMARCA
unidos podemos más



CUNDINAMARCA
"EL DORADO"
"LA LEYENDA VIVE"



Muestra de Tejido
Material: En Dos Agujas
Tejido: Trenzas

TEJIDO TERMINADO



TEJIDO TERMINADO



MUESTRAS PROBETAS

Municipio: Fúquene

Oficio: Tejeduría

Técnicas: Cestería y Tejido de estera

Material: Junco y Enea



Tejido Tafetán sencillo



Tejido Tafetán doble



Tejido Sarga



Muestras trenzados y anudados

MUESTRAS PROBETAS

Municipio: Fúquene

Oficio: Tejeduría

Técnicas: Telar horizontal

Material: Junco y Enea



Tejido plano Tafetán con hilos algodón



Muestras tonos en degradé

MUESTRAS PROBETAS

Municipio: La Calera

Oficio: Tejeduría

Técnicas: Telar horizontal

Materiales: Lana – Hilos de bordar



Tejido en crochet



Bordado a mano



Bordado a mano



Tintes naturales y texturas
en telar horizontal

MUESTRAS PROBETAS

Municipio: La Calera

Oficio: Tejeduría

Técnicas: Telar horizontal

Material: Hilos mezcla lana y acrílicos



Tejido plano



Tejido plano



Muestras tonos en degradé



MUESTRAS PROBETAS

Municipio: Zipaquirá

Oficio: Lítico en sal

Técnicas: Talla en sal de roca

Material: Sal



Material en bruto



Prueba laja en sal



Prueba producto portavasos

MUESTRAS PROBETAS

Municipio: Zipaquirá

Oficio: Tejeduría / trabajos en cuero

Técnicas: Tejido entrecruzados

Material: Jean/ media lana/ cuero



Muestras trabajo en retal de tela de jean



Muestras hilos media lana



Muestras tejido en cintas de cuero

MUESTRAS PROBETAS

Municipio: Zipaquirá

Oficio: Tejeduría

Técnicas: Tejido Crochet / dos agujas

Material: Lana



Muestra Tejido en crochet



Muestra tejido en dos agujas



Muestra tejido dos agujas

MUESTRAS PROBETAS

Municipio: Chía

Oficio: Tejeduría

Técnicas: crochet

Material: Lana/trapillo/ hilo acrilico



Muestra Texturas varios materiales



Muestras tejidos texturas varios materiales y técnicas

MUESTRAS PROBETAS
Municipio: Utica – Palma de Iraca

**PALMA DE
IRACA**



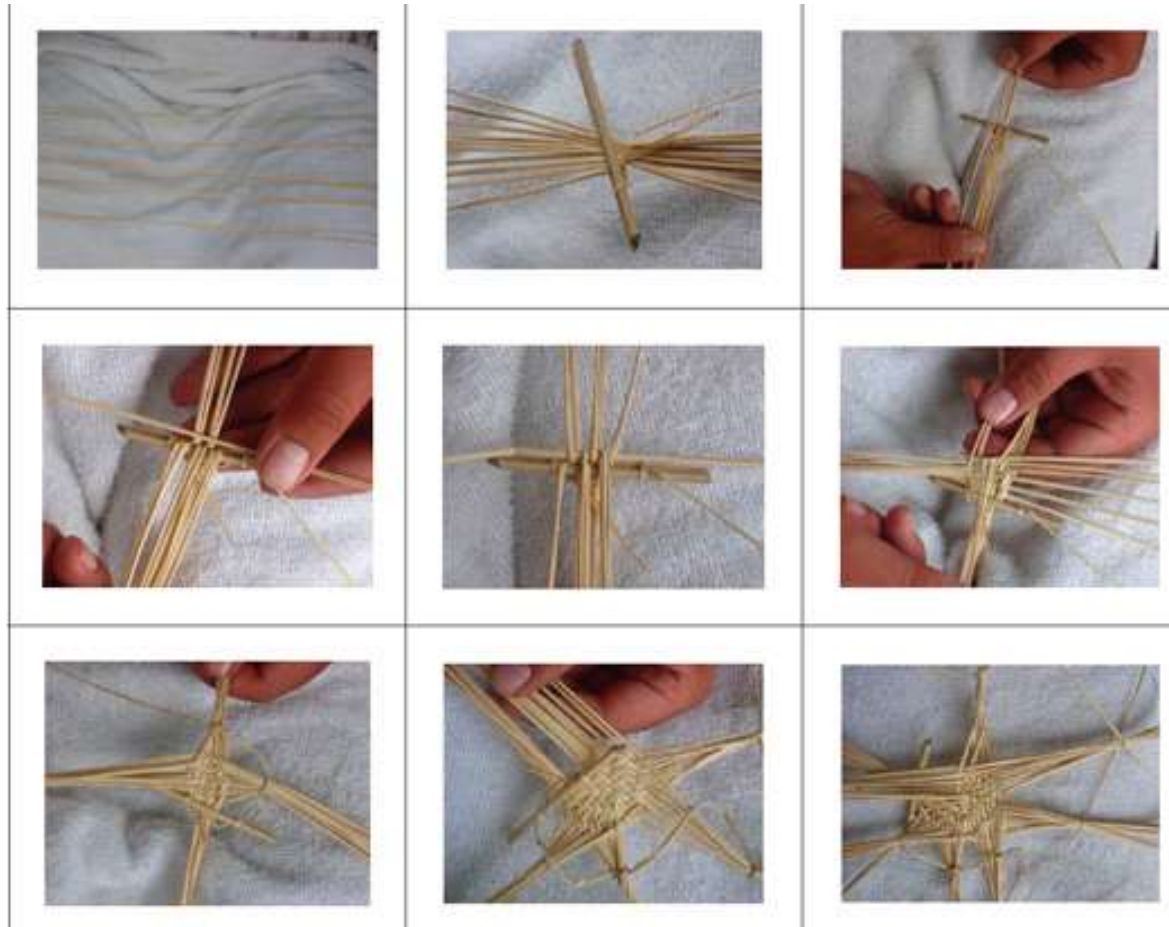

Inicio de Tejido



Inicio de Tejido



GOBIERNO
DE COLOMBIA



MINCIT



artesanías de colombia



SEC MUJER
Y EQUIDAD DE GÉNERO
GOBERNACIÓN DE CUNDINAMARCA



CUNDINAMARCA
unidos podemos más



CUNDINAMARCA
"EL DORADO"
"LA LEYENDA VIVE"



Inicio de Tejido

CLASES DE TEJIDOS

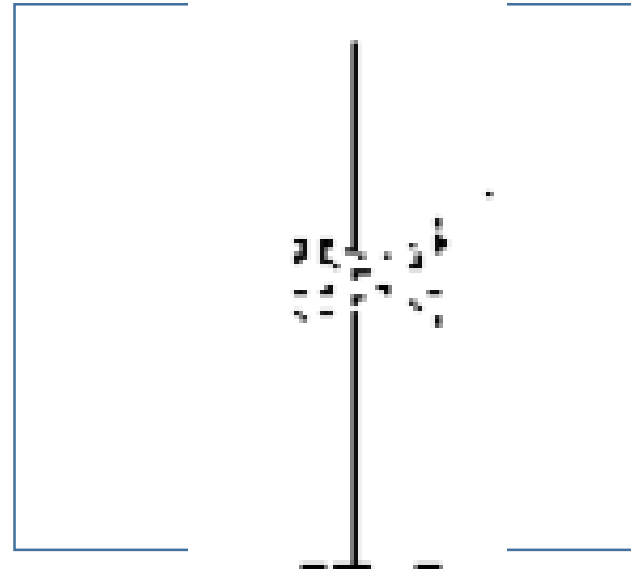

Tejido: TRENZA

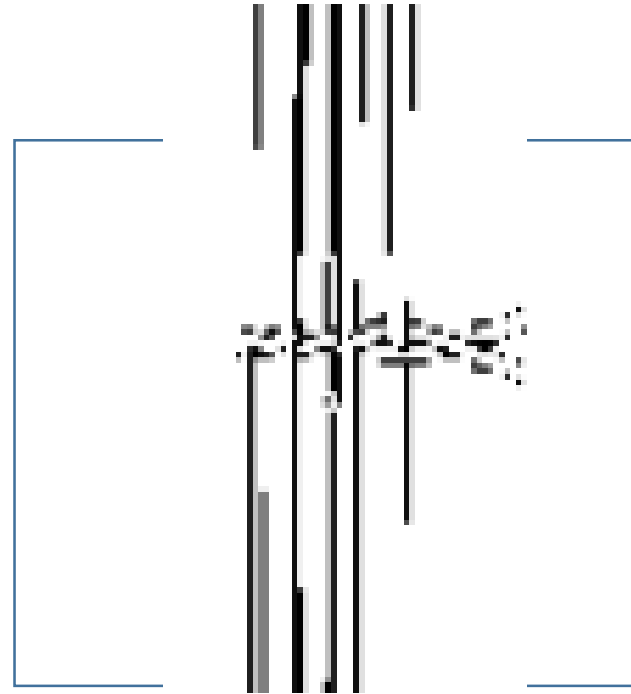

Tejido: TRENZA

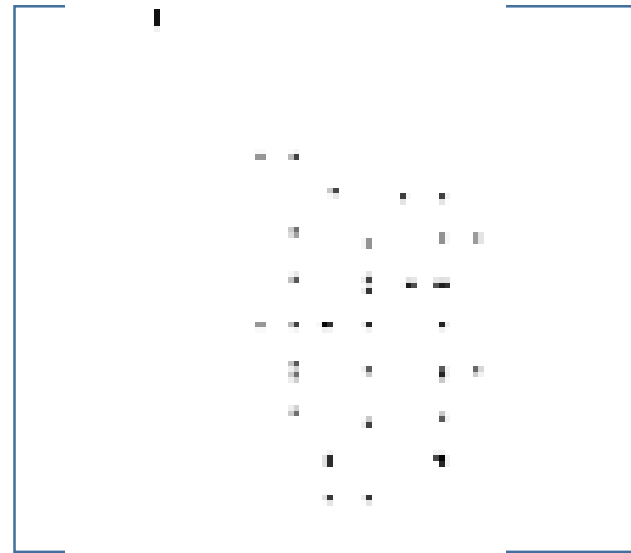

Tejido: RINON

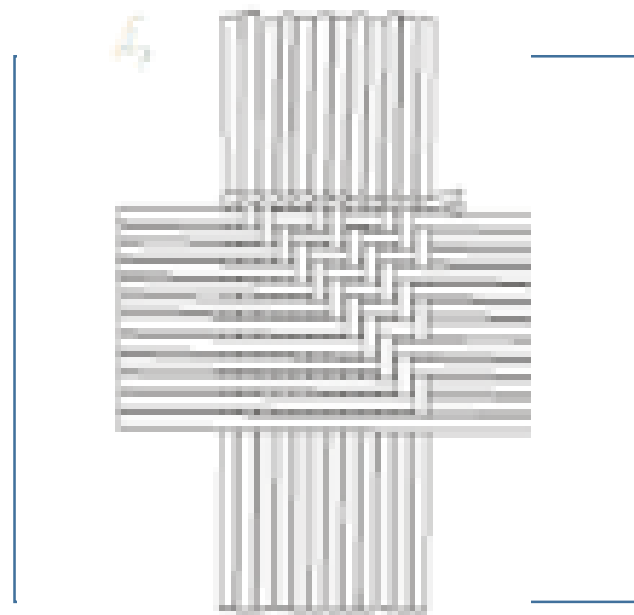

Tejido: ESTERILLA



GOBIERNO DE COLOMBIA



MINCIT



artesanías de colombia



SEC MUJER Y EQUIDAD DE GÉNERO
GOBERNACIÓN DE CUNDINAMARCA



CUNDINAMARCA
unidos podemos más



CUNDINAMARCA
"EL DORADO"
"LA LEYENDA VIVE"

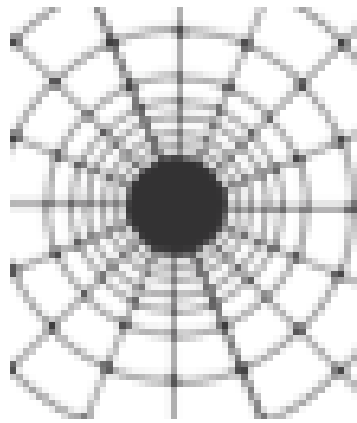

Muestra de Tejido
Material: Palma de Iraca

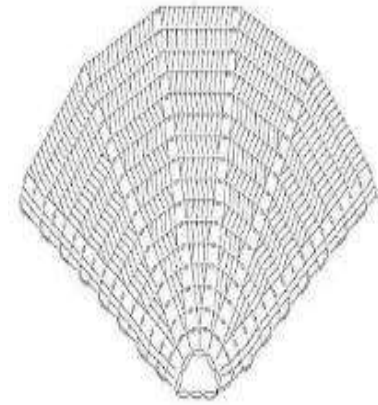

Muestra de Tejido
Material: Palma de Iraca

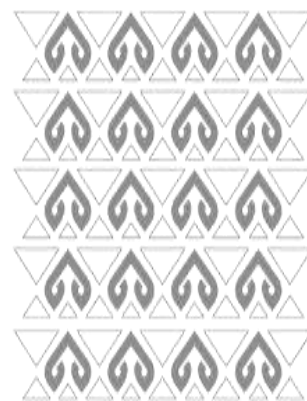

Muestra de Tejido
Material: Palma de Iraca

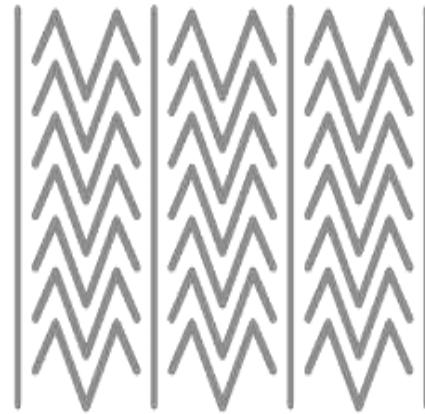

Muestra de Tejido
Material: Palma de Iraca



GOBIERNO
DE COLOMBIA



MINCIT



artesanías de colombia



SEC MUJER
Y EQUIDAD DE GÉNERO
GOBERNACIÓN DE CUNDINAMARCA



CUNDINAMARCA
unidos podemos más



CUNDINAMARCA
"EL DORADO"
"LA LEYENDA VIVE"



Muestra de Tejido
Material: Palma de Iraca



GOBIERNO
DE COLOMBIA



MINCIT



artesanías de colombia



SEC MUJER
Y EQUIDAD DE GÉNERO
GOBERNACIÓN DE CUNDINAMARCA



CUNDINAMARCA
unidos podemos más



CUNDINAMARCA
"EL DORADO"
"LA LEYENDA VIVE"



Muestra de Tejido
Material: Palma de Iraca
Tejido:



GOBIERNO
DE COLOMBIA



MINCIT



artesanías de colombia



SEC MUJER
Y EQUIDAD DE GÉNERO
GOBERNACIÓN DE CUNDINAMARCA



CUNDINAMARCA
unidos podemos más



CUNDINAMARCA
"EL DORADO"
"LA LEYENDA VIVE"



Muestra de Tejido
Material: Palma de Iraca



Muestra de Tejido
Material: Palma de Iraca



GOBIERNO
DE COLOMBIA



MINCIT



artesanías de colombia



SEC MUJER
Y EQUIDAD DE GÉNERO
GOBERNACIÓN DE CUNDINAMARCA



CUNDINAMARCA
unidos podemos más



CUNDINAMARCA
"EL DORADO"
"LA LEYENDA VIVE!"



Muestra de Tejido
Material: Palma de Iraca



GOBIERNO
DE COLOMBIA



MINCIT



artesanías de colombia



SEC MUJER
Y EQUIDAD DE GÉNERO
GOBERNACIÓN DE CUNDINAMARCA



CUNDINAMARCA
unidos podemos más



CUNDINAMARCA
"EL DORADO"
"LA LEYENDA VIVE!"



Muestra de Tejido
Material: Palma de Iraca

TEJIDO TERMINADO



TEJIDO TERMINADO

