

REFERENTES DE DISEÑO PARA LA COMUNIDAD DE SAN FRANCISCO

**“PROGRAMA DE FORTALECIMIENTO PRODUCTIVO Y EMPRESARIAL
PARA PUEBLOS INDÍGENAS DE COLOMBIA”**

Referentes De La Comunidad



Tejeduría Contemporánea



Tejeduría Tradicional

Referentes De La Comunidad



Tejeduría Tradicional

“PROGRAMA DE FORTALECIMIENTO PRODUCTIVO Y EMPRESARIAL PARA PUEBLOS INDÍGENAS DE COLOMBIA”

Referentes De La Comunidad



Tejeduría Contemporánea



Tejeduría Tradicional

“PROGRAMA DE FORTALECIMIENTO PRODUCTIVO Y EMPRESARIAL PARA PUEBLOS INDÍGENAS DE COLOMBIA”

Referentes Gráficos

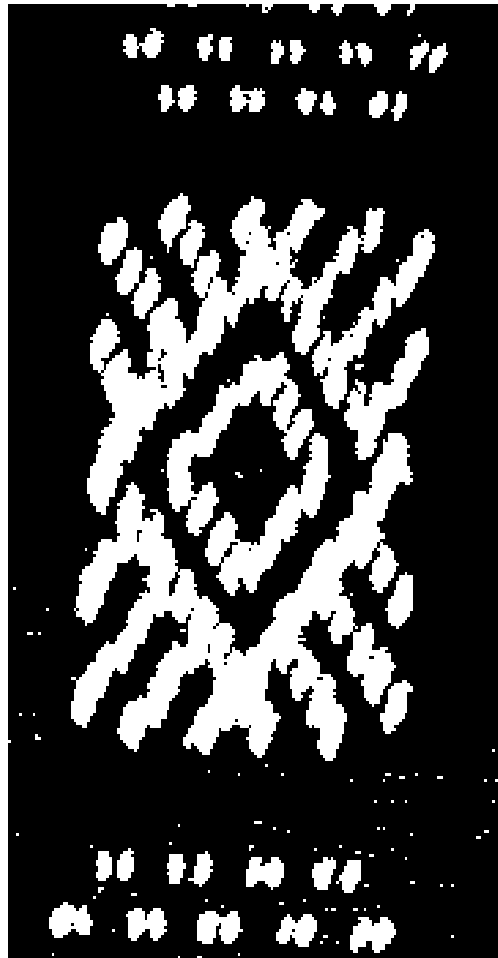

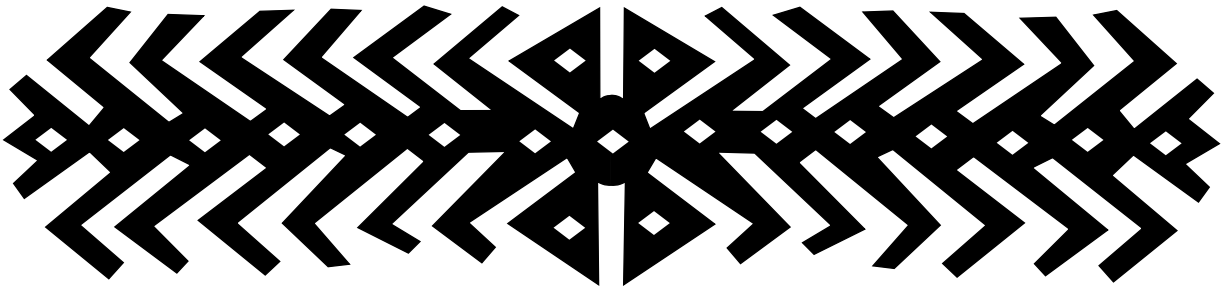

Maíz

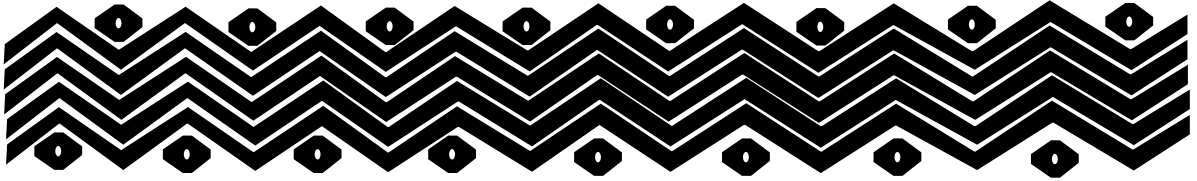

Rio



Camino

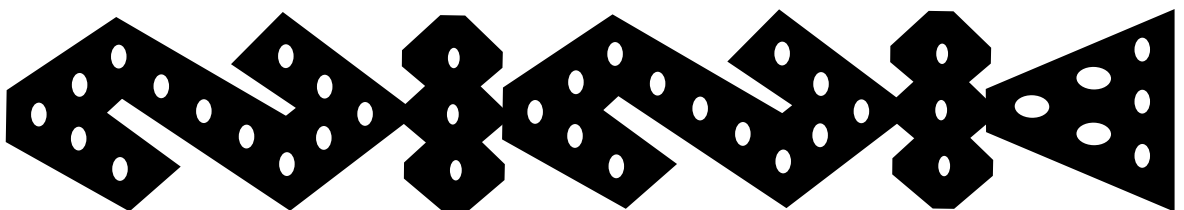
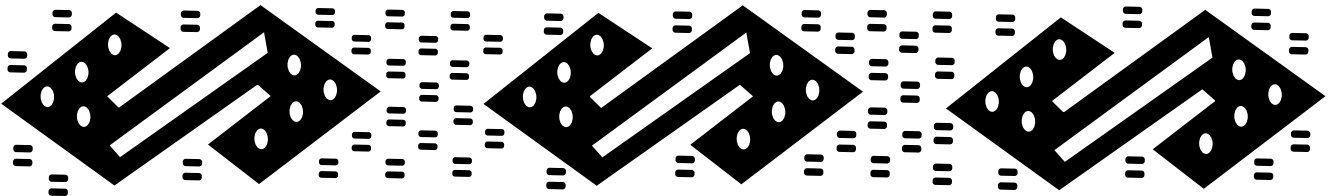
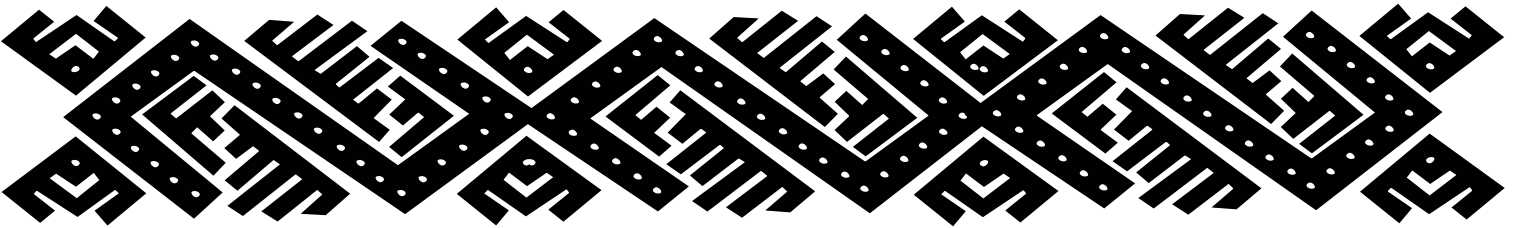

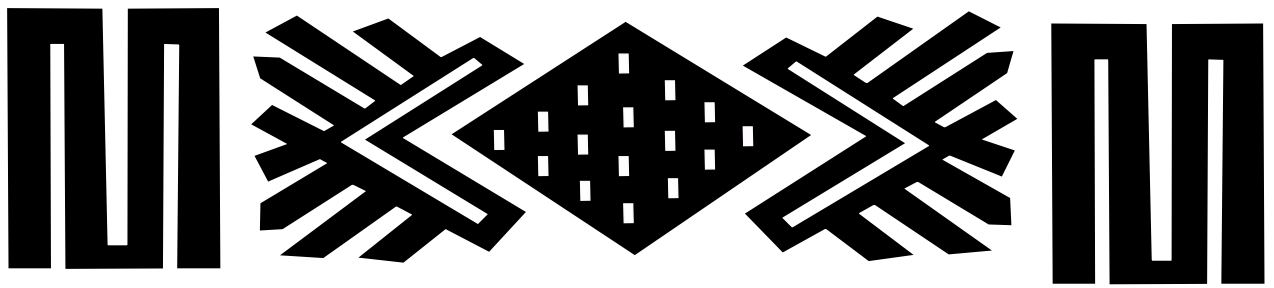

Flor Carnaval

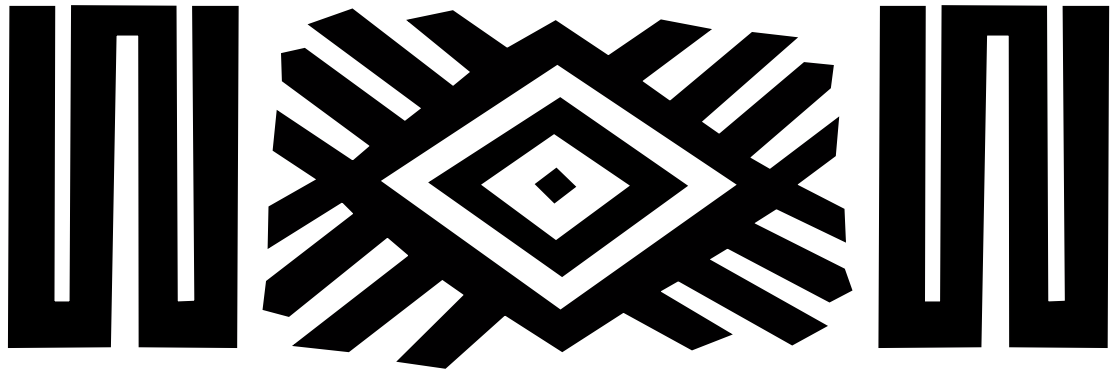

SOL

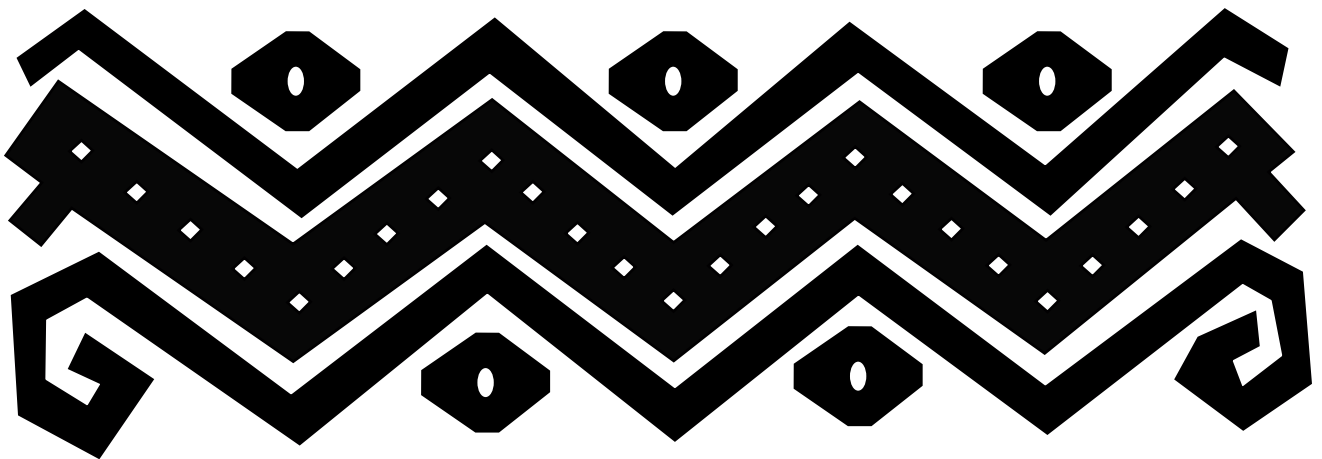

Nido culebra

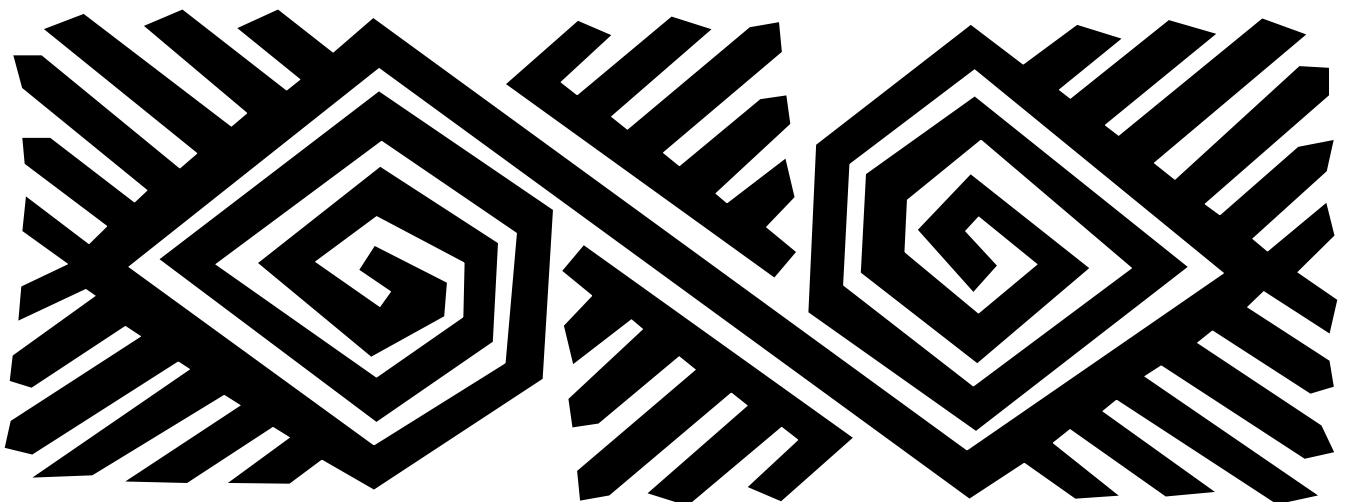

Cabeza del Saraguay - Personaje del carnaval
Representación que recuerda el engaño de los blancos
(espejos).

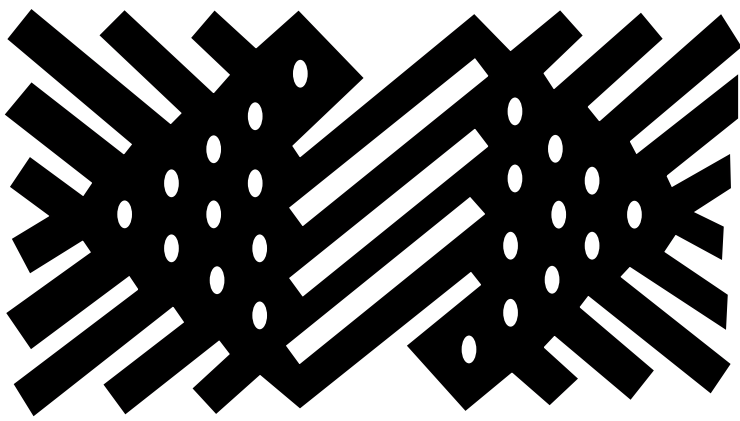

Oso

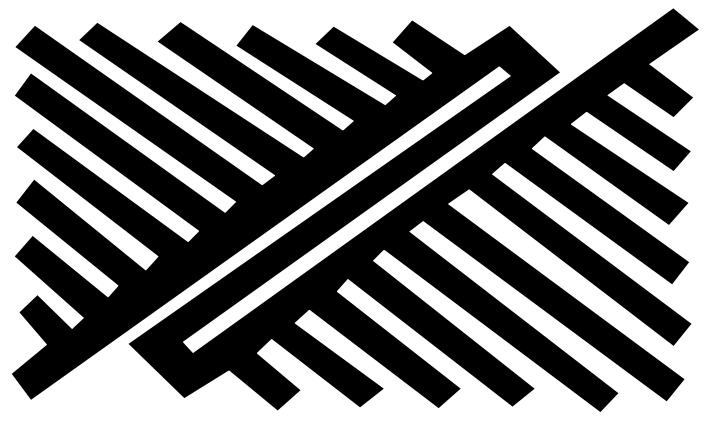

Rondador - Instrumento musical
carnaval - armonía

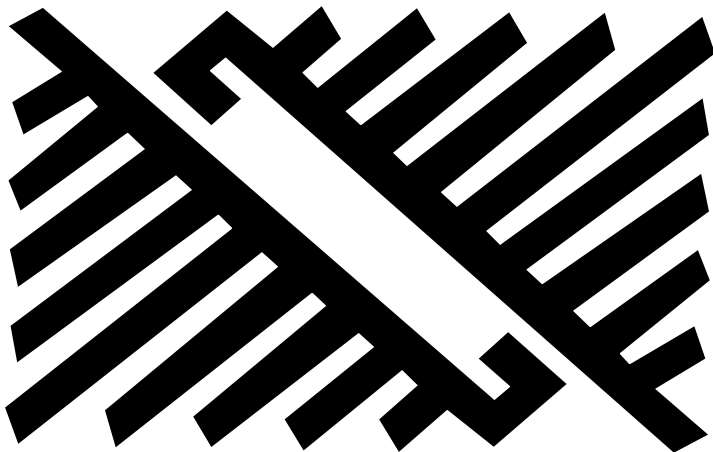

Alas

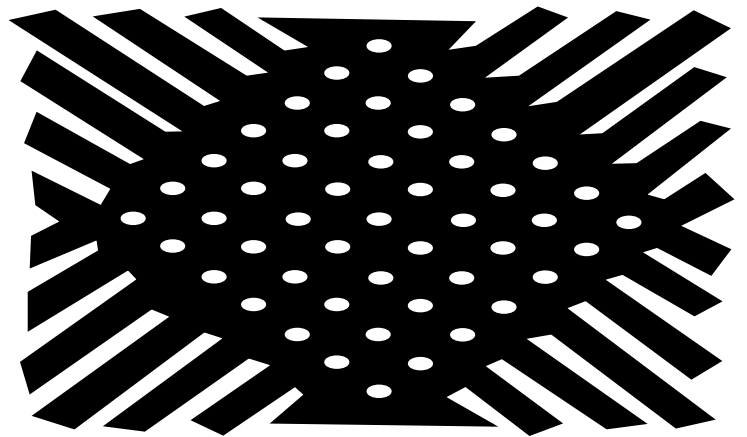

Erizo

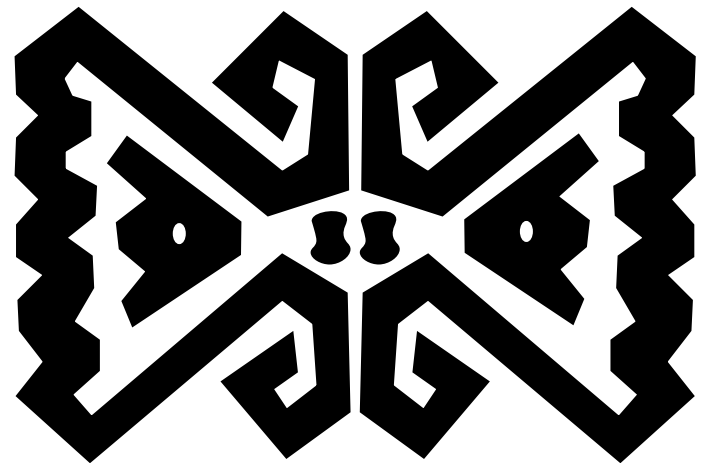
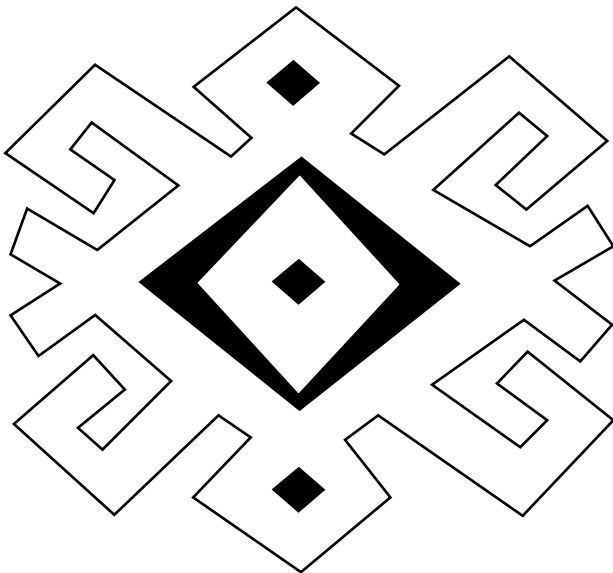

Luna

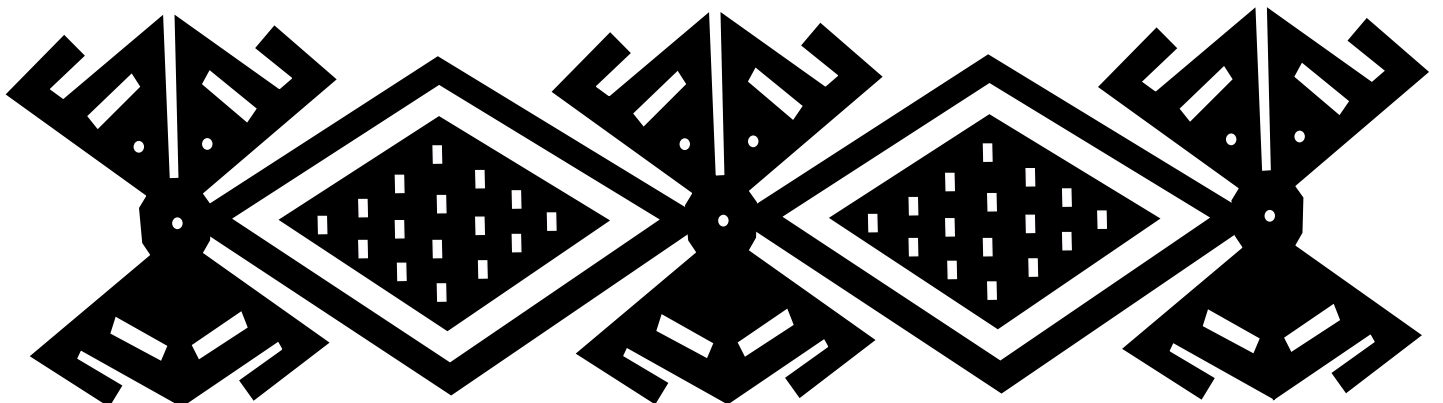

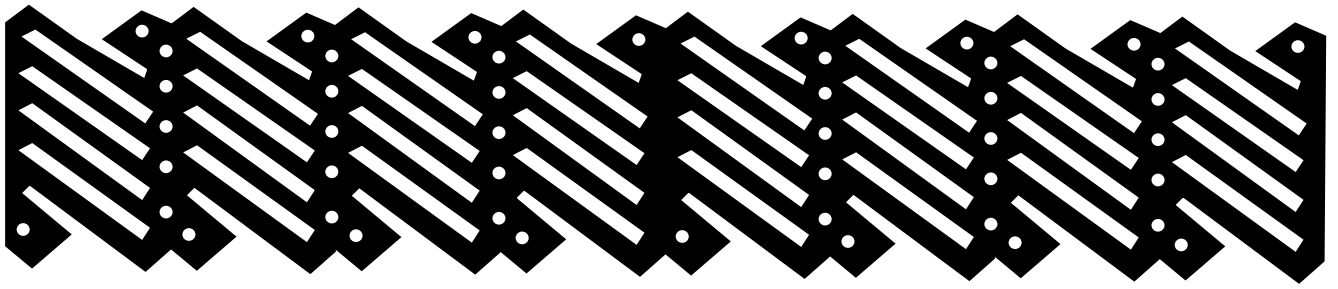

Semilla - Surcos

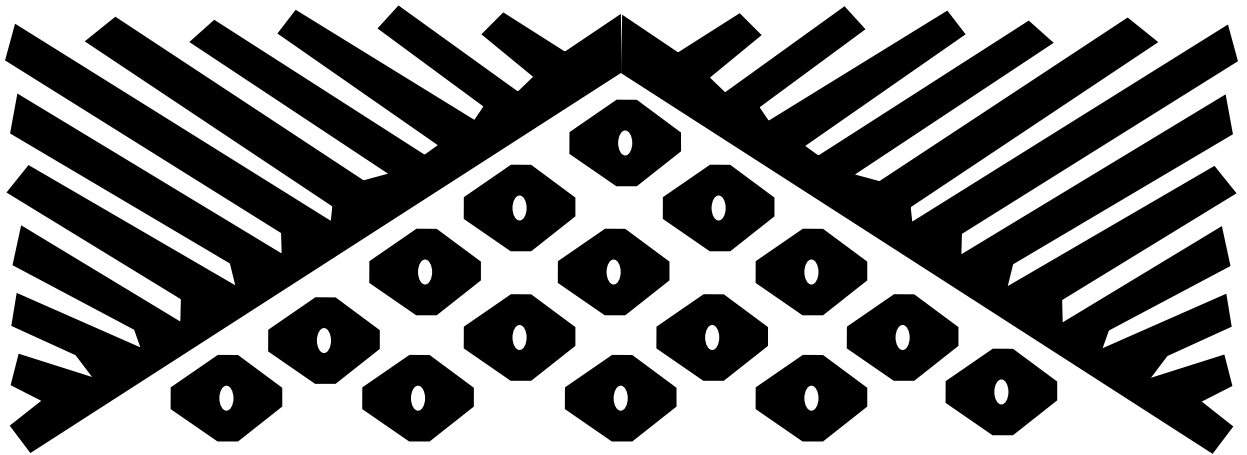
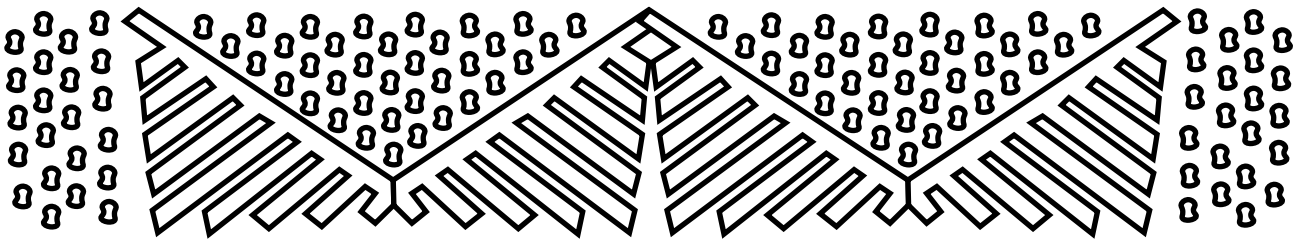

Arco Iris



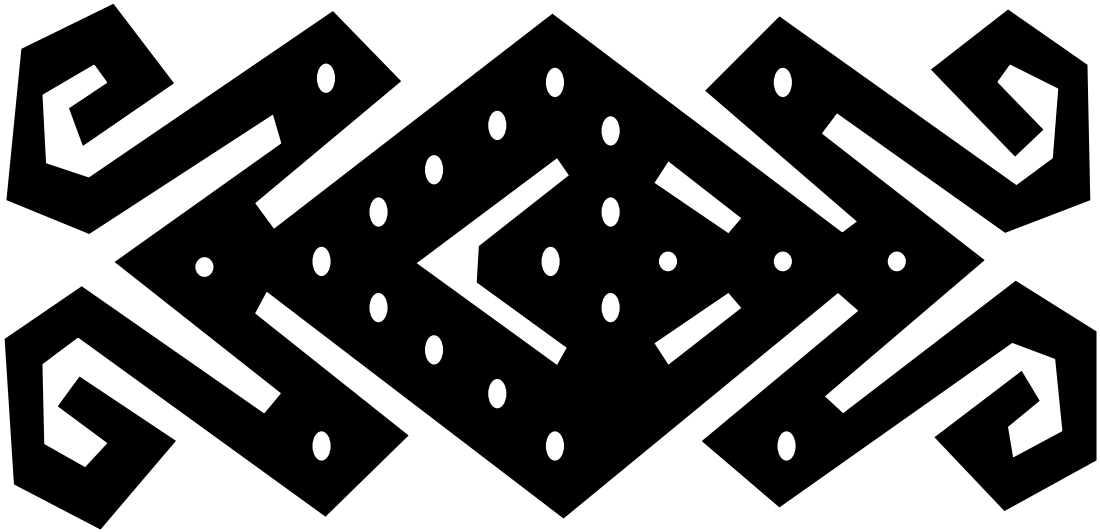

Rana

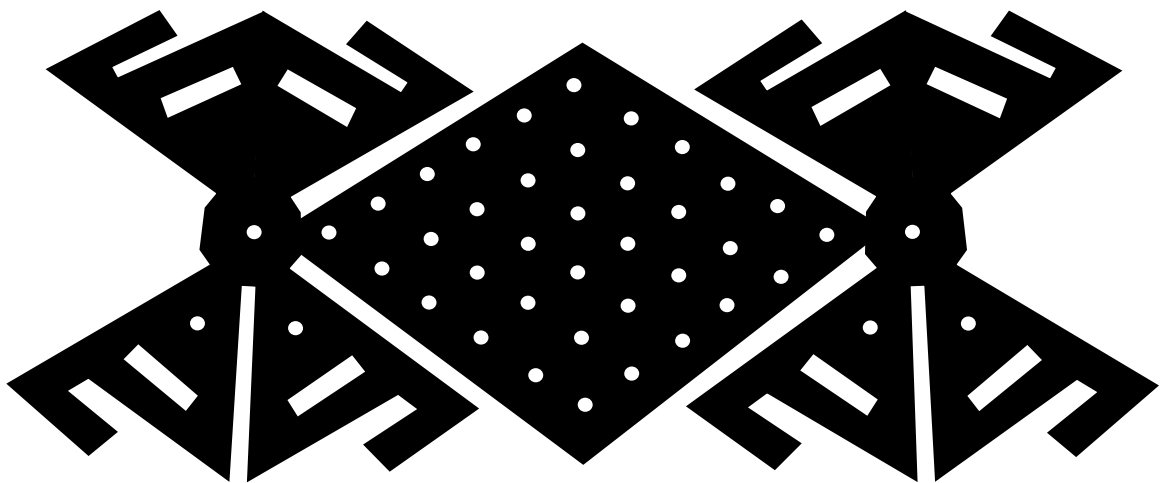
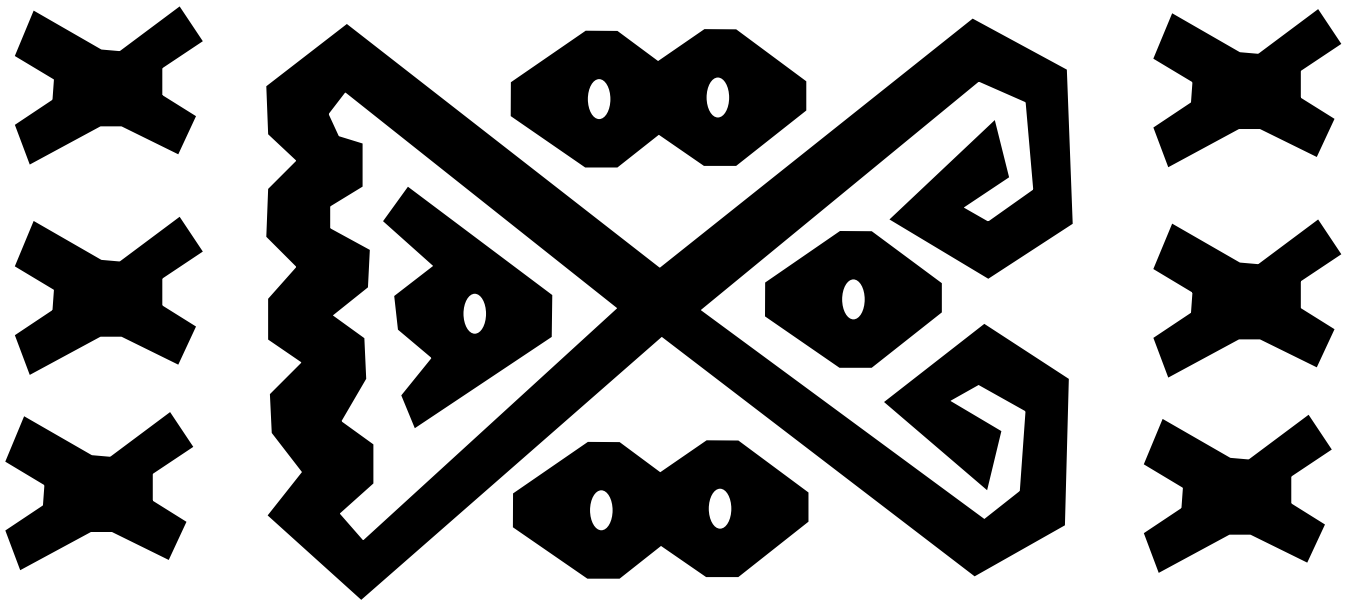

Ventre - Manos

Referentes De Tendencias Textiles



Configuraciones a partir de plantillas



Patrones geométricos

Referentes De Tendencias Moda



Gráficas que hacen el todo del objeto

MATRIZ DE DISEÑO SAN FRANCISCO - PUTUMAYO

Comunidad	Oficio	Concepto general	Línea de producto	Idea de diseño	Pieza/s referente	Referente gráfico	Piezas línea de producto	Referente de Tendencia	Color	Materiales	Función	
San Francisco	Tejeduría	Entre el cambio y la permanencia	Línea 1: Hogar Decoración-Tejeduría Guanga	Innovación de piezas textiles con énfasis en la exaltación técnica y de simbología camentsa en tejeduría en Guanga, enfatizada hacia la decoración.			Cojin de Piso			Hilo Acrílico	Utilitaria	
							Otomano				Utilitaria	
							Caminos de Mesa				Utilitaria	
			Línea 2: Mesa	Rediseño de piezas textiles con énfasis en la exaltación técnica y de simbología camentsa en tejeduría en Guanga, enfatizada hacia la mesa			Caminos de Mesa				Hilos de Fantasía y Acrílicos	Utilitaria-Decorativa
							Individuales				Utilitaria-Decorativa	
											Utilitaria-Decorativa	

BOCETOS LINEAS DE DISEÑO PARA LA COMUNIDAD DE SAN FRANCISCO

**“PROGRAMA DE FORTALECIMIENTO PRODUCTIVO Y EMPRESARIAL
PARA PUEBLOS INDÍGENAS DE COLOMBIA”**

San Francisco – Decoración y hogar

CAMBIO Línea hogar

Referentes



Tendencias



Paleta de color

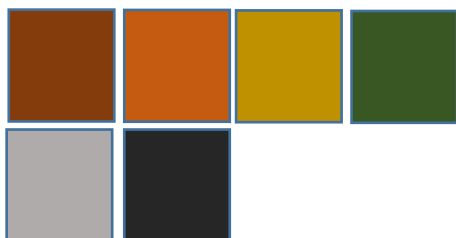

Composición de simbología
gráfica de forma lineal

PROPUESTA EN DISEÑO

Cojín de piso



Otomano



San Francisco – Mesa y cocina

CAMBIO Línea mesa

Referentes



Tendencias



Paleta de color

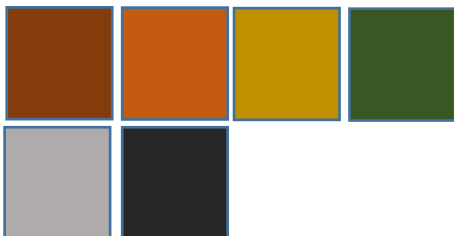

Composición de simbología grafica de forma lineal

PROPUESTA EN DISEÑO

Camino de mesa



Individuales

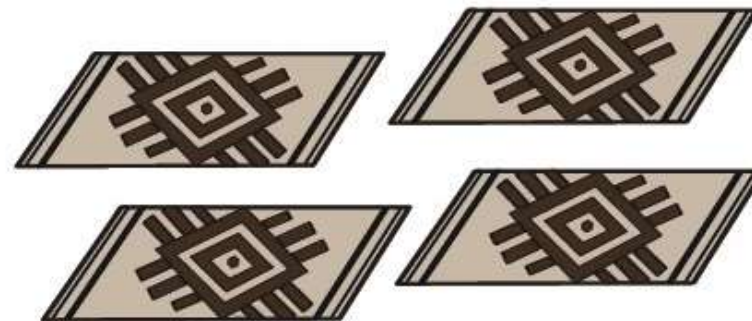

CAMBIO

Juego de mesa baja y butacos

Referentes



Tendencias

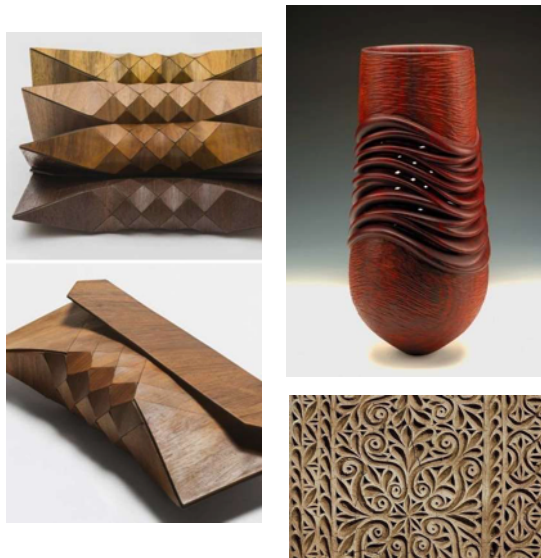

Paleta de color
Natural

Perfección en la
geometría, uso
del color,
generación de
texturas

PROPUESTA EN DISEÑO

Exaltación de tonos de la madera, mejora
de acabados

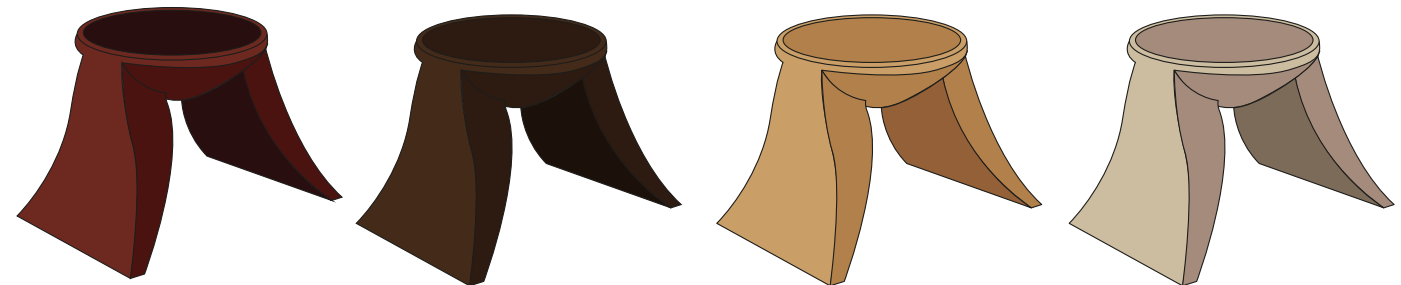

CAMBIO

Juego de mesa baja y butacos

Referentes



Tendencias

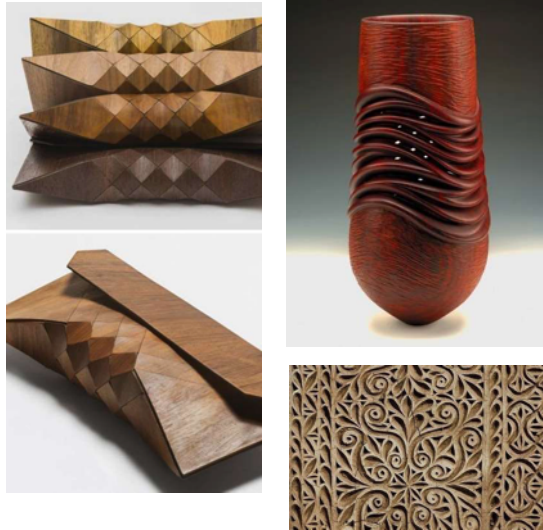

Paleta de color
Natural

Perfección en la
geometría, uso
del color,
generación de
texturas

PROPUESTA EN DISEÑO

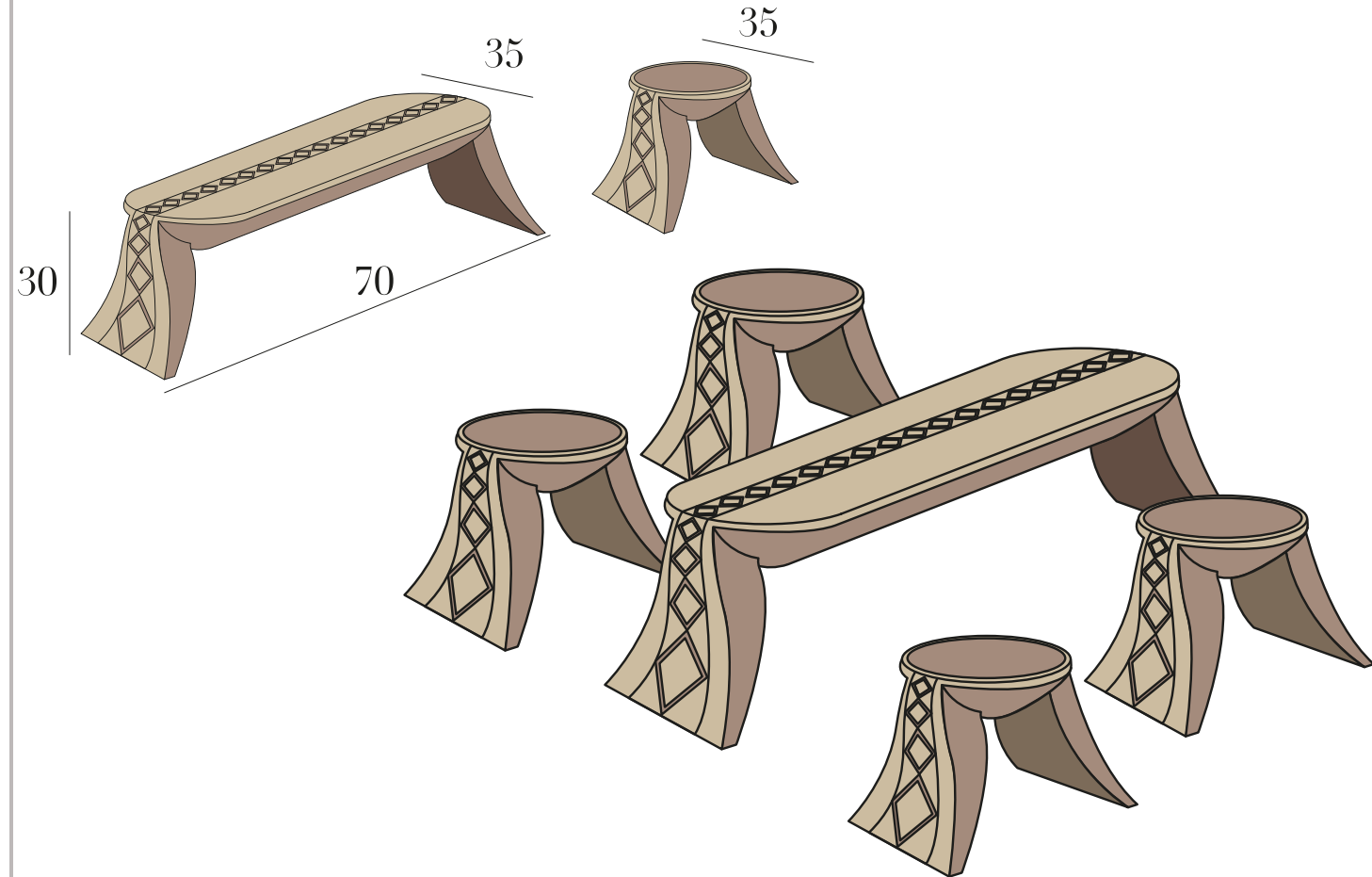

San Francisco– Decoración y hogar



CAMBIO

Juego de mesa baja y butacos

Referentes



Tendencias

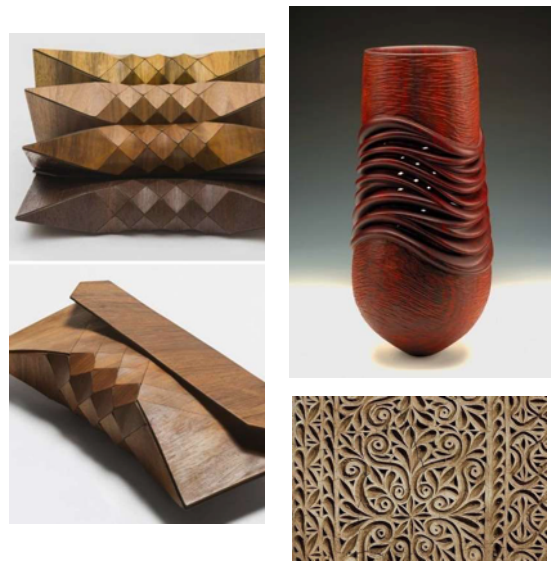

Paleta de color
Natural

Perfección en la
geometría, uso
del color,
generación de
texturas

PROPUESTA EN DISEÑO

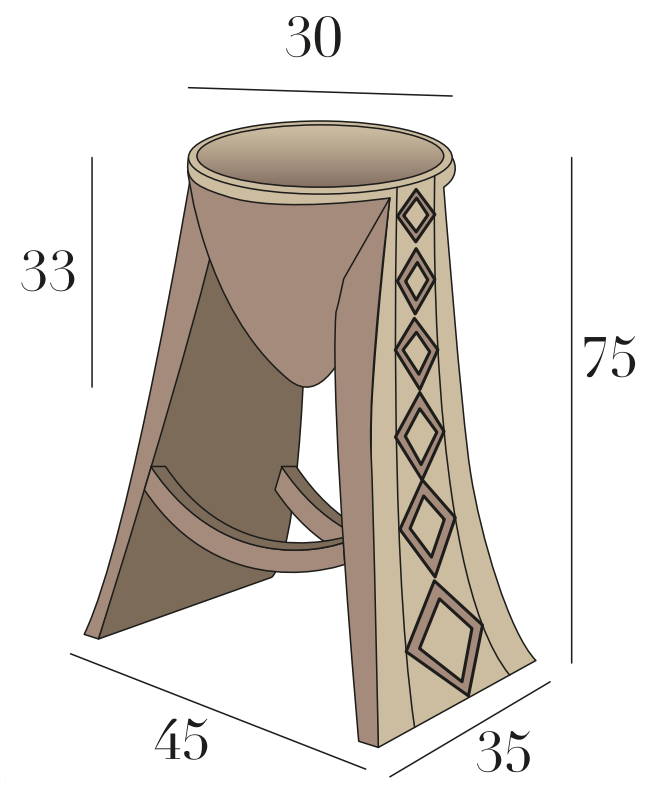
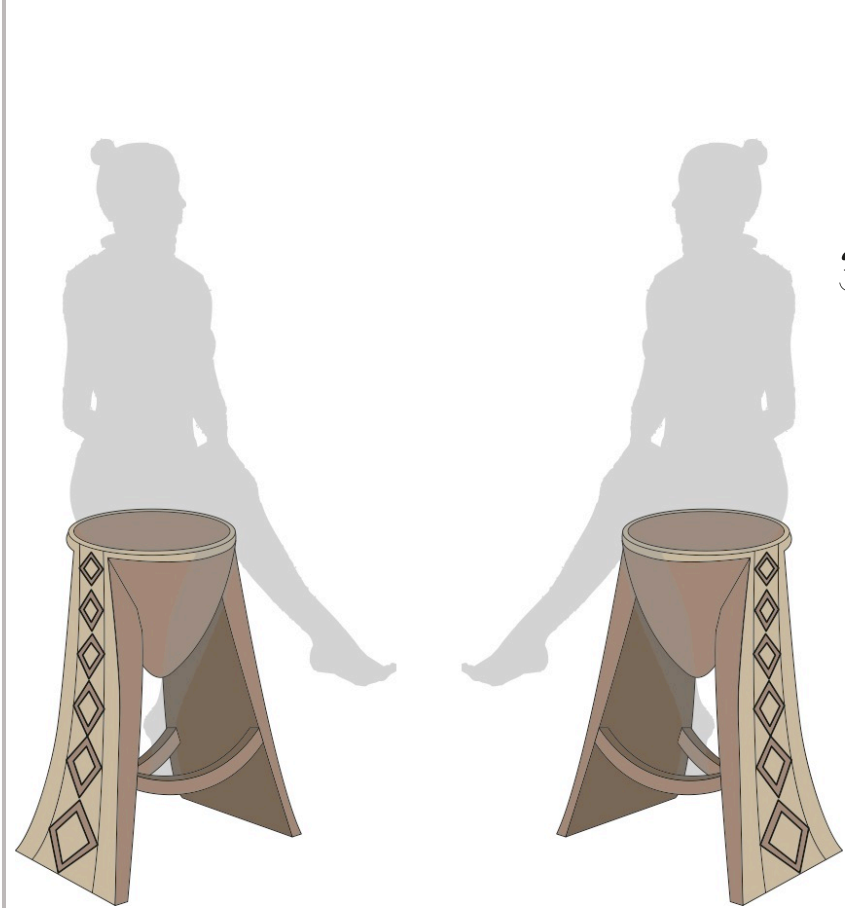

CAMBIO

Linea de bateas talladas

Referentes



Tendencias

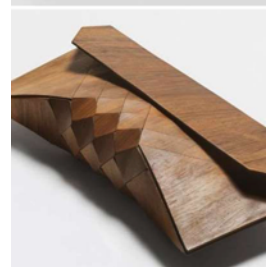

Paleta de color
Natural

Perfección en la
geometría, uso del color,
generación de texturas

“PROGRAMA DE FORTALECIMIENTO PRODUCTIVO Y EMPRESARIAL PARA PUEBLOS INDÍGENAS DE COLOMBIA”

PROPUESTA EN DISEÑO

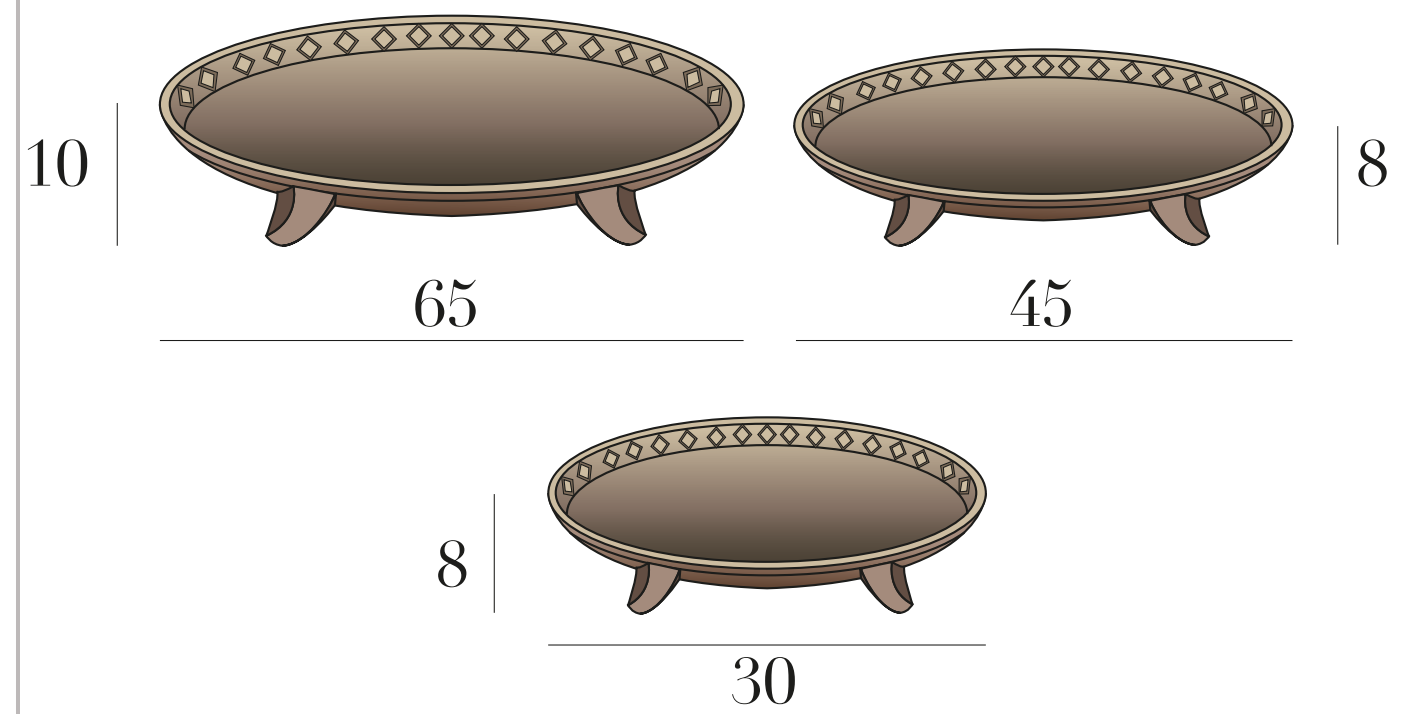

San Francisco– Decoración y hogar



CAMBIO

Linea de canastos contenedores

Referentes



Paleta de color
Natural

PROPUESTA EN DISEÑO

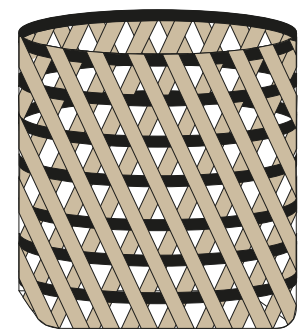

24

25

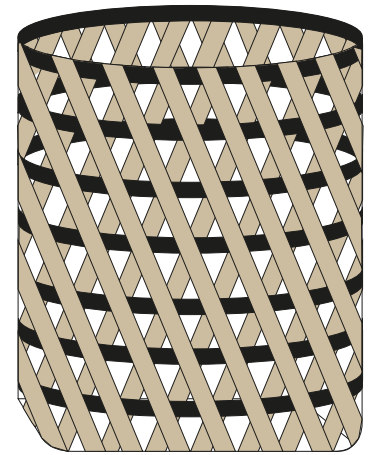

30

35

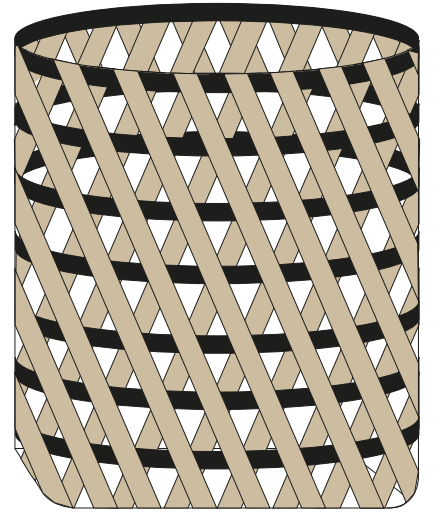

35

45

San Francisco– Decoración y hogar



CAMBIO

Linea de canastos contenedores

Referentes



Paleta de color
Natural

PROPUESTA EN DISEÑO

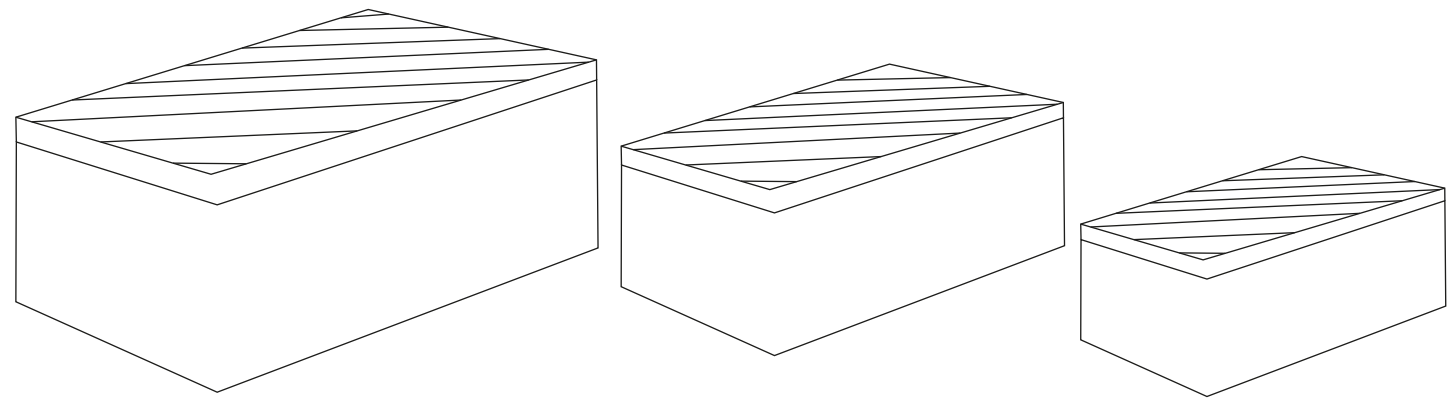

FICHAS DE DISEÑO PARA LA COMUNIDAD DE SAN FRANCISCO

**“PROGRAMA DE FORTALECIMIENTO PRODUCTIVO Y EMPRESARIAL
PARA PUEBLOS INDÍGENAS DE COLOMBIA”**

FORMATO FICHA DE PRODUCTO



En Proceso

Producto Terminado o en proceso de desarrollo

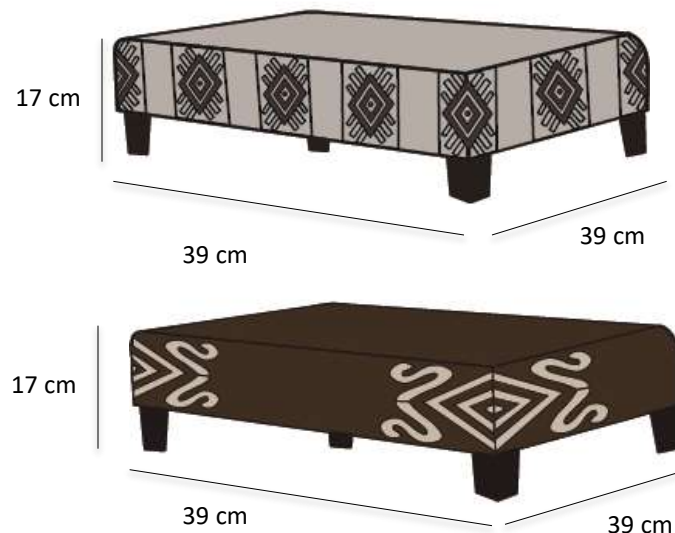

Boceto o plano con dimensiones generales

Nombre de la pieza: Otomano	
Etnia: Camëntsa - Inga	Comunidad: San Francisco
Municipio: San Francisco	Departamento: Putumayo
Artesano: Carmen Agreda	Oficio: Tejeduría
Técnica: Telar guanga	Materia Prima: Orlón – Hilo guajiro
Línea: Hogar	Función: Decoración
Ancho: 39 cm	Alto: 17 cm
Largo: 39 cm	Diámetro N/A
Color: Contraste Negro Blanco	



Pieza referente/Punto de partida

FORMATO FICHA DE PRODUCTO

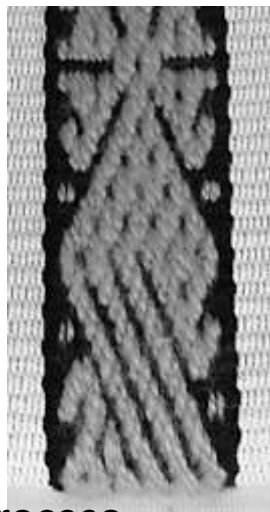

En proceso

Producto Terminado o en proceso de desarrollo



17 cm

50 cm



17 cm

50 cm

Boceto o plano con dimensiones generales

Nombre de la pieza: Cojín de piso	
Etnia: Camëntsa - Inga	Comunidad: San Francisco
Municipio: San Francisco	Departamento: Putumayo
Artesano: Carmen Agreda	Oficio: Tejeduría
Técnica: Telar guanga	Materia Prima: Orlón – Hilo guajiro
Línea: Hogar	Función: Decoración
Ancho: N/A	Alto: 17 cm
Largo: N/A	Diámetro: 50 cm
Color: Colores tierra	



Pieza referente/Punto de partida

FORMATO FICHA DE PRODUCTO



En Proceso

Producto Terminado o en proceso de desarrollo

35 cm



1,60 mts

Boceto o plano con dimensiones generales

Nombre de la pieza: Camino de mesa	
Etnia: Camëntsa - Inga	Comunidad: San Francisco
Municipio: San Francisco	Departamento: Putumayo
Artesano: Carmen Agreda	Oficio: Tejeduría
Técnica: Telar guanga	Materia Prima: Orlón – Hilo guajiro
Línea: Hogar	Función: Decoración
Ancho: 35 cm	Alto: N/A
Largo: 1.60 mts	Diámetro: N/A
Color: Colores Naturales	

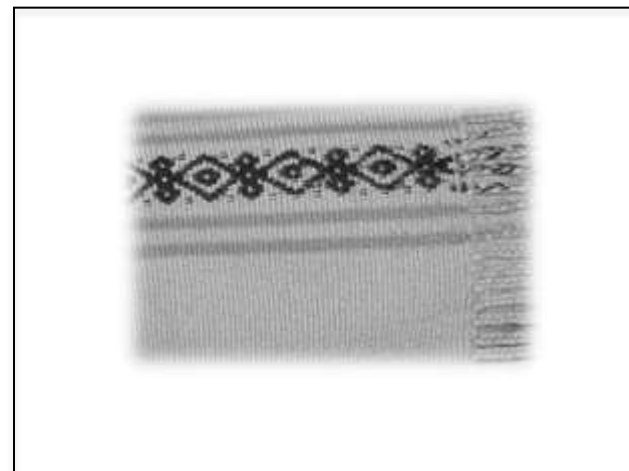

Pieza referente/Punto de partida

FORMATO FICHA DE PRODUCTO



En proceso

Producto Terminado o en proceso de desarrollo

35 cm



1,50 cm

Boceto o plano con dimensiones generales

Nombre de la pieza: Camino de mesa	
Etnia: Camëntsa - Inga	Comunidad: San Francisco
Municipio: San Francisco	Departamento: Putumayo
Artesano: Carmen Agreda	Oficio: Tejeduría
Técnica: Telar guanga	Materia Prima: Orlón – Hilo guajiro
Línea: Hogar	Función: Decoración
Ancho: 35 cm	Alto:
Largo: 1.50 mts	Diámetro
Color: Colores tierra	

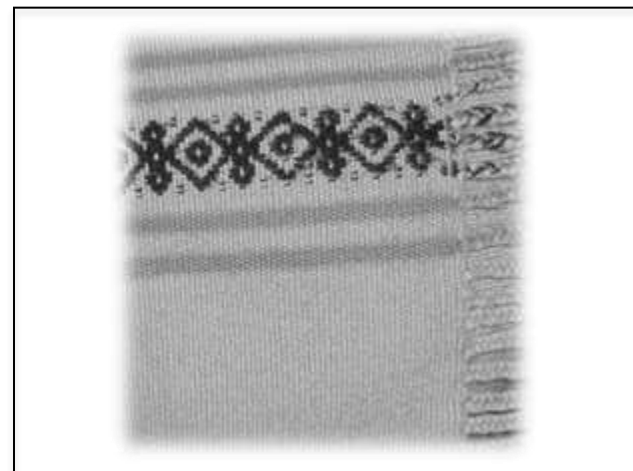

Pieza referente/Punto de partida

FORMATO FICHA DE PRODUCTO



Producto Terminado o en proceso de desarrollo

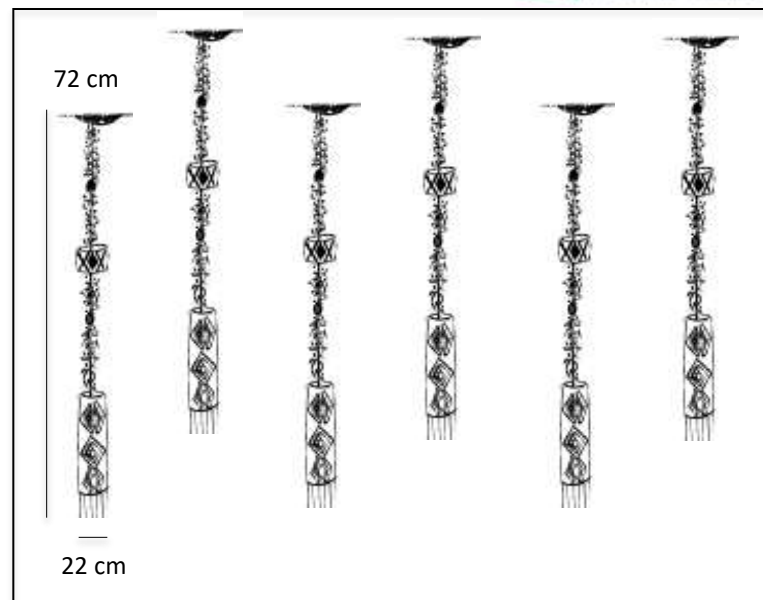

Boceto o plano con dimensiones generales

Nombre de la pieza: Mobiles	
Etnia: Camëntsa - Inga	Comunidad: San Francisco
Municipio: San Francisco	Departamento: Putumayo
Artesano: Carmen Agreda	Oficio: Tejeduría
Técnica: Telar Chaquirá	Materia Prima: Chaquirá Checa
Línea: Hogar	Función: Decoración
Ancho: N/A	Alto: 72 cm
Largo: N/A	Diámetro 22 cm
Color: Colores tradicionales	



Pieza referente/Punto de partida

FORMATO FICHA DE PRODUCTO

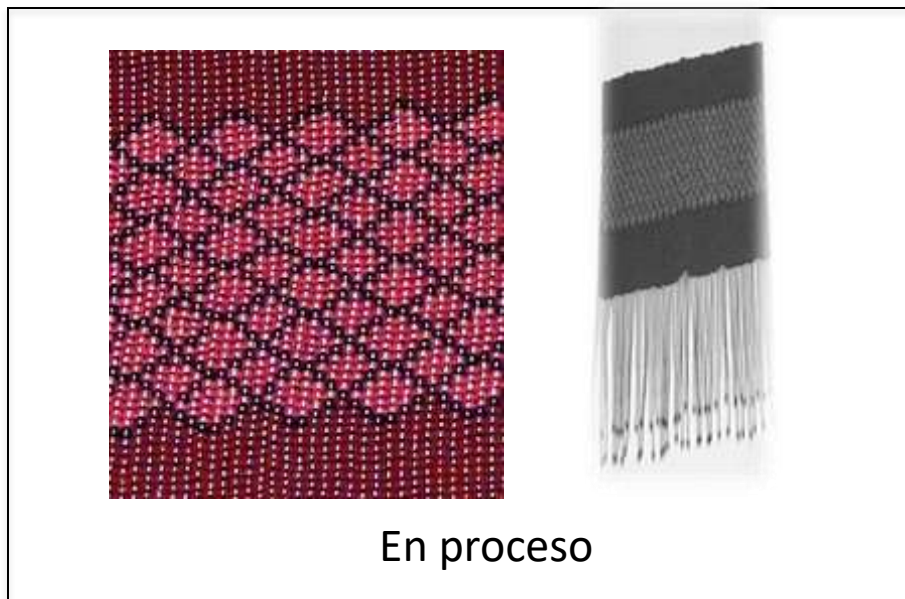

Producto Terminado o en proceso de desarrollo

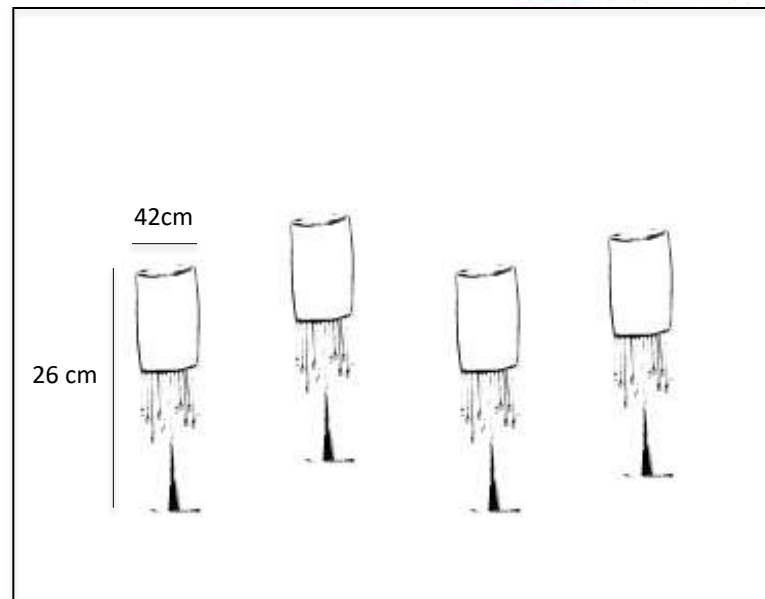

Boceto o plano con dimensiones generales

Nombre de la pieza: lámpara de mesa	
Etnia: Camëntsa - Inga	Comunidad: San Francisco
Municipio: San Francisco	Departamento: Putumayo
Artesano: Carmen Agreda	Oficio: Tejeduría
Técnica: Telar de Chaquira	Materia Prima: Chaquira e Hilo Aptan
Línea: Hogar	Función: Decoración
Ancho: N/A	Alto: 26 cm
Largo: N/A	Diámetro: 42 cm
Color: Colores tradicionales	



Pieza referente/Punto de partida

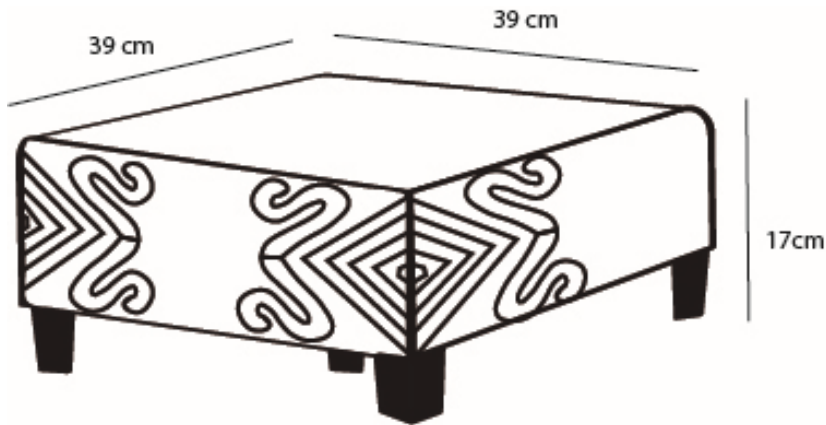

1	Tela lana	lana		300.00
2	Estructura	Mdf		
No.	Pieza	Material	Cant	Porc%
Tabla de Componentes				

Nombre de la pieza Otoman		Referencia: Otoman San Francisco		ESC.	
Oficio: Tejeduría	Tecnica: Tejido plano en telar vertical	Materia Prima:			
Especificaciones Técnicas: Tejeduría en telar Vertical, lana natural					
Color: Negro	Capacidad de Producción / mes: 26-50		Dimensiones Generales		
Peso (gr.): 850	Precio Unitario	Precio por Mayor	Largo: 39	Ancho: 39	Alto: 17
Artesano: AGREDA CERON CARMELA	Telefono:		Diametro:		
Grupo o Taller:	Departamento: Putumayo	Municipio: San Francisco			
Certificado Hecho a mano: <input checked="" type="checkbox"/> Si <input type="checkbox"/> No	Centro Poblado:	<input type="checkbox"/> Resguardo Caserio	<input type="checkbox"/> Localidad Vereda	<input type="checkbox"/> N/A Corrimiento	
Observaciones: Prototipo					Terminado <input type="checkbox"/> En Proceso <input type="checkbox"/>
Responsable: Galindo Angela Maria		Dibujante:			
Aprobado por:		Fecha:	<input type="checkbox"/> Referentes <input type="checkbox"/> Línea		
					Muestra <input checked="" type="checkbox"/> <input type="checkbox"/>

50 cm



32 cm

50 cm



17cm



1	tejido 1,5	lana		550.00
2	cojin interno	spuma	200.00	
No.	Pieza	Material	Cant	Porc%
Tabla de Componentes				

Nombre de la pieza cojin de piso		Referencia: cojin de piso San Francisco		ESC.	
Oficio: Tejeduría	Tecnica: Tejido plano en telar vertical	Materia Prima:			
Especificaciones Técnicas: Tejeduría en telar Vertical, lana natural					
Color: Negro	Capacidad de Producción / mes: 26-50		Dimensiones Generales		
Peso (gr.): 650	Precio Unitario	Precio por Mayor	Largo:	Ancho:	Alto: 17
Artesano: AGREDA CERON CARMELA	Telefono:				Diametro: 50
Grupo o Taller:	Departamento: Putumayo	Municipio: San Francisco			
Certificado Hecho a mano: <input type="checkbox"/> Si <input checked="" type="checkbox"/> No	Centro Poblado:	<input type="checkbox"/> Resguardo Caserio	<input type="checkbox"/> Localidad Vereda	<input type="checkbox"/> N/A Corrimiento	
Observaciones: Prototipo					Terminado <input type="checkbox"/> En Proceso <input type="checkbox"/>
Responsable: Galindo Angela Maria		Dibujante:			
Aprobado por:		Fecha:	<input type="checkbox"/> Referentes <input type="checkbox"/> Línea		
					Muestra <input checked="" type="checkbox"/> <input type="checkbox"/>

13cm

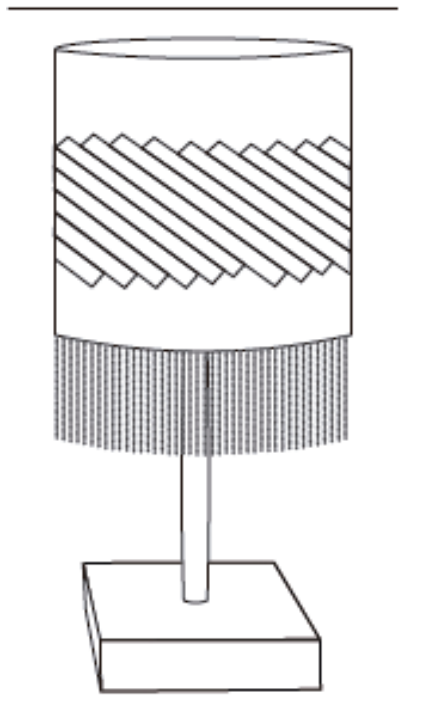

32cm

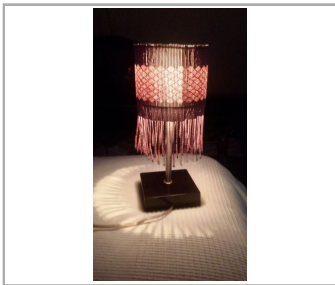

1	Tejido	chaquira	370.00	
2	Estructura	acero	1.00	
No.	Pieza	Material	Cant	Porc%
Tabla de Componentes				

Nombre de la pieza lampara de mesa		Referencia: Otoman San Francisco		ESC.	
Oficio: Tejeduría		Tecnica: Tejido plano en telar vertical		Materia Prima:	
Especificaciones Técnicas: Tejeduría en telar chaquira					
Color: Negro		Capacidad de Producción / mes: 26-50		Dimensiones Generales	
Peso (gr.): 750		Precio Unitario		Precio por Mayor	
Artisano: AGREDA CERON CARMELA		Telefono:		Largo: 32	Ancho: 13
Grupo o Taller:		Departamento: Putumayo		Municipio: San Francisco	
Certificado Hecho a mano: <input type="checkbox"/> Si <input checked="" type="checkbox"/> No		Centro Poblado:		<input type="checkbox"/> Resguardo Caserio	<input type="checkbox"/> Localidad Vereda
Observaciones: Prototipo				<input type="checkbox"/> N/A Corrimiento	
Responsable: Galindo Angela Maria		Dibujante:		Terminado <input checked="" type="checkbox"/> En Proceso <input type="checkbox"/>	
Aprobado por:		Fecha:			
				<input type="checkbox"/> Referentes <input type="checkbox"/> Línea <input checked="" type="checkbox"/> Muestra	

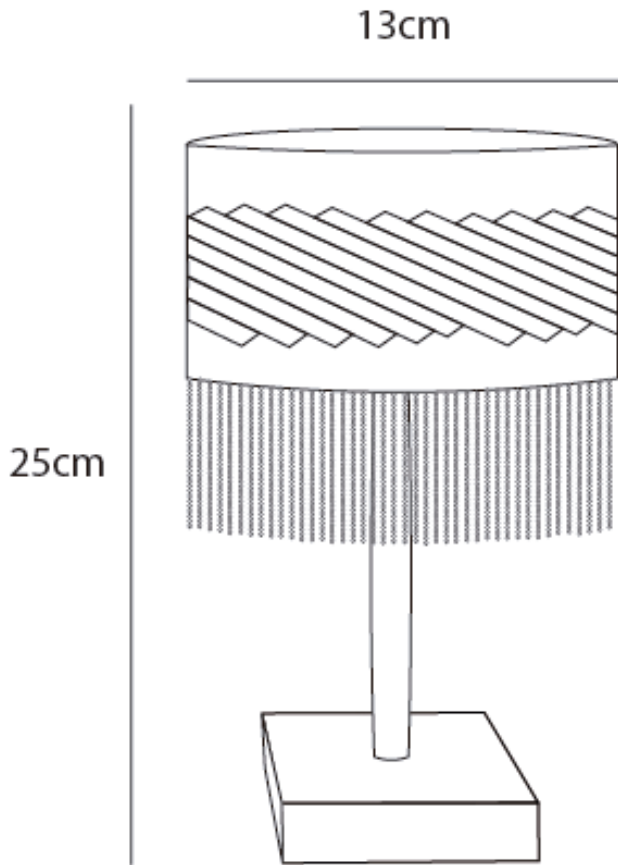

1	Tejido en chaquira	Varias		250.00
2	Estructura	Varias		
Tabla de Componentes				
No.	Pieza	Material	Cant	Porc%

Nombre de la pieza lampara de mesa 1		Referencia: lampara 1		ESC.	
Oficio: Tejeduría		Tecnica: Tejido plano en telar vertical		Materia Prima:	
Especificaciones Técnicas: Tejeduría en telar chaquira					
Color: Negro		Capacidad de Producción / mes: 26-50		Dimensiones Generales	
Peso (gr.): 450		Precio Unitario		Precio por Mayor	
Artisano: AGREDA CERON CARMELA		Telefono:		Largo:	Ancho:
Grupo o Taller:		Departamento: Putumayo		Municipio: San Francisco	
Certificado Hecho a mano: <input type="checkbox"/> Si <input checked="" type="checkbox"/> No		Centro Poblado:		<input type="checkbox"/> Resguardo Caserio	<input type="checkbox"/> Localidad Vereda
Observaciones: Prototipo				<input type="checkbox"/> N/A Corrimiento	
Responsable: Galindo Angela Maria		Dibujante:		Terminado <input checked="" type="checkbox"/> En Proceso <input type="checkbox"/>	
Aprobado por:		Fecha:			

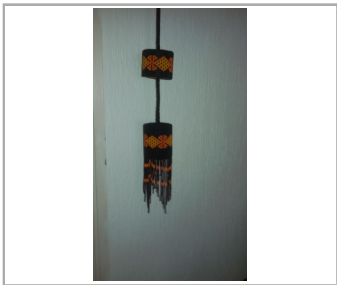
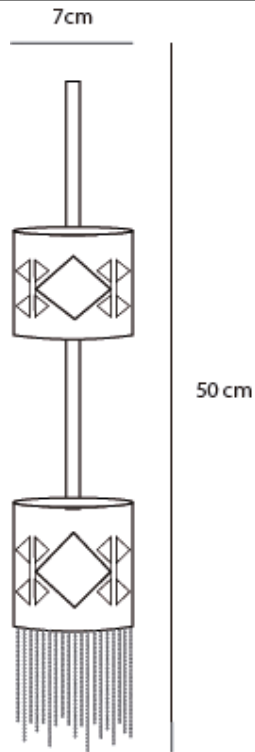

1	Tejido	Piedras sintéticas		370.00
2	tejido	chaquiras		200.00
No.	Pieza	Material	Cant	Porc%
Tabla de Componentes				

Nombre de la pieza mobil		Referencia: cojín de piso San Francisco		ESC.	
Oficio: Tejeduría	Tecnica: Tejido Chaquira	Materia Prima:			
Especificaciones Técnicas: Tejeduría en telar Chaquira					
Color: Negro	Capacidad de Producción / mes: 51-100		Dimensiones Generales		
Peso (gr.): 570	Precio Unitario	Precio por Mayor	Largo: 50	Ancho: 7	Alto:
Artesano: AGREDA CERON CARMELA	Telefono:		Diametro:		
Grupo o Taller:	Departamento: Putumayo	Municipio: San Francisco			
Certificado Hecho a mano: <input checked="" type="checkbox"/> Si <input type="checkbox"/> No	Centro Poblado:	<input type="checkbox"/> Resguardo Caserio	<input type="checkbox"/> Localidad Vereda	<input type="checkbox"/> N/A Corrimiento	
Observaciones: Prototipo					Terminado <input checked="" type="checkbox"/> En Proceso <input type="checkbox"/>
Responsable: Galindo Angela Maria		Dibujante:			
Aprobado por:		Fecha:	<input type="checkbox"/> Referentes <input type="checkbox"/> Línea		
					Muestra <input checked="" type="checkbox"/> <input type="checkbox"/>