

# Camminos

ENTRE EL CAMBIO Y LA  
PERMANENCIA

## MATRIZ DE DISEÑO Y BOCETOS

“PROGRAMA DE FORTALECIMIENTO PRODUCTIVO Y EMPRESARIAL  
PARA PUEBLOS INDÍGENAS DE COLOMBIA”





# Caminos

**ENTRE EL CAMBIO  
Y LA PERMANENCIA**

**Una entrada y una salida**

**Un inicio y un final**

**Un recorrido, una transición entre lo que  
somos y lo que queremos ser.**

**Aquellos puntos intermedios en los cuales se  
encuentran nuestras comunidades entre la  
tradición y la permanencia cultural vs la  
evolución y el progreso.**



\*PROGRAMA DE FORTALECIMIENTO PRODUCTIVO Y EMPRESARIAL PARA PUEBLOS INDÍGENAS DE COLOMBIA\*

# Camminos

EN LA PERMANENCIA

*Rescate*

*Elementos y acabados rústicos*

*Formas irregulares*

*Colores naturales, colores tierra y colores tradicionales de la comunidad.*

*Simbología gráfica y formal.*





# Camminos

EN LA PERMANENCIA

*Rediseño e innovación*

*Formas lineales o geométricas*

*Saturación de texturas*

*Contrastes*

*Colores de tendencia*

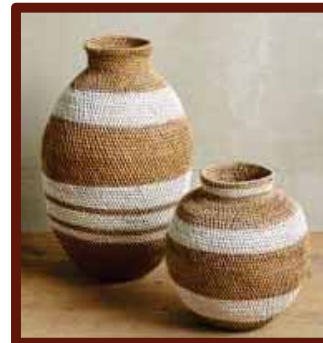

Ca  
mi  
nos  
ENTRE EL CAMBIO  
Y LA PERMANENCIA



“PROGRAMA DE FORTALECIMIENTO PRODUCTIVO Y EMPRESARIAL PARA PUEBLOS INDÍGENAS DE COLOMBIA”  
“PROGRAMA DE FORTALECIMIENTO PRODUCTIVO Y EMPRESARIAL PARA PUEBLOS INDÍGENAS DE COLOMBIA”

# Líneas

DE PRODUCTO

*Vestuario y Accesorios*

*Decoración y hogar*

*Mesa y Cocina*



Ca  
mi  
nos  
ENTRE EL CAMBIO  
Y LA PERMANENCIA



“PROGRAMA DE FORTALECIMIENTO PRODUCTIVO Y EMPRESARIAL PARA PUEBLOS INDÍGENAS DE COLOMBIA”  
“PROGRAMA DE FORTALECIMIENTO PRODUCTIVO Y EMPRESARIAL PARA PUEBLOS INDÍGENAS DE COLOMBIA”



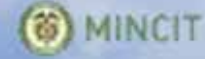

# Vestuario y accesorios

“PROGRAMA DE FORTALECIMIENTO PRODUCTIVO Y EMPRESARIAL PARA PUEBLOS INDÍGENAS DE COLOMBIA”

# Asocit - Vestuario y accesorios



## PERMANENCIA

Mochilas tradicionales  
Arhuacas "tutu"

Referentes



Tendencias



Acentos en las mismas tonalidades

## PROPUESTA EN DISEÑO

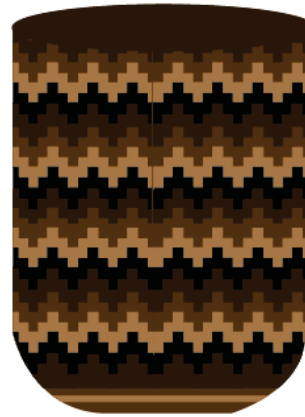

Paleta de color de los tonos de la lana natural

Tejidos con mínimo tres colores diferentes de lana.

"PROGRAMA DE FORTALECIMIENTO PRODUCTIVO Y EMPRESARIAL PARA PUEBLOS INDÍGENAS DE COLOMBIA"

ca  
mi  
nos  
ENTRE EL CAMBIO  
Y LA PERMANENCIA



# Maicao - Vestuario y accesorios



## PERMANENCIA

Mochilas tradicionales  
Wayuu "Susu"

### Tendencias



Patrones  
geométricos en full  
color

### Referentes



## PROPUESTA EN DISEÑO

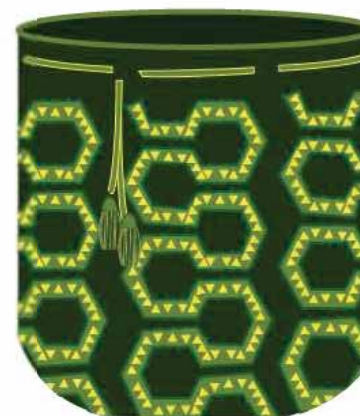

Rescate de Simbología tradicional o "Kannas".



Tamaño  
Base: Ø23cms  
Alto: 27cms

Paletas monocromaticas

Ca  
mi  
nos  
ENTRE EL CAMBIO  
Y LA PERMANENCIA



# Maicao - Vestuario y accesorios



## ENTRE EL CAMBIO Y LA PERMANENCIA.

Waireñas o Calzado tradicional Wayuu,  
con aplicación de carta de color.

### Referentes



### Tendencias



Geométrías en alto contraste



Paleta de color  
contrastes

## PROPUESTA EN DISEÑO

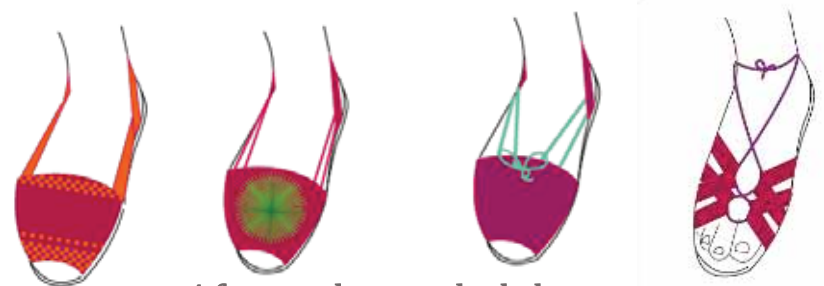

4 formas de armado de la  
Waireña



1. Con apliques en Borlas



2. Amarres con Cordón



3. Cerrada con diseños en la  
capellada



3. Cerrada con diseños en la  
capellada

Ca  
mi  
nos  
ENTRE EL CAMBIO  
Y LA PERMANENCIA

# Maicao - Vestuario y accesorios



ENTRE EL CAMBIO Y LA PERMANENCIA.  
Waireñas o Calzado tradicional Wayuu,  
con aplicación de carta de color.

Referentes



Tendencias



Geométrías en alto contraste



Paleta de color  
contrastes

PROPUESTA EN DISEÑO



1. Diseño totalmente  
cerrado



2. Diseño con talonera.



Tejidos en la capellada



“PROGRAMA DE FORTALECIMIENTO PRODUCTIVO Y EMPRESARIAL PARA PUEBLOS INDÍGENAS DE COLOMBIA”

**nos**  
ENTRE EL CAMBIO  
Y LA PERMANENCIA



# Chorrera-Vestuario y accesorios



ENTRE EL CAMBIO  
Y LA PERMANENCIA.

Línea de mochilas

Referentes



Tendencias



Patrones lineales

Paleta de color  
Tonos naturales



PROPUESTA EN DISEÑO

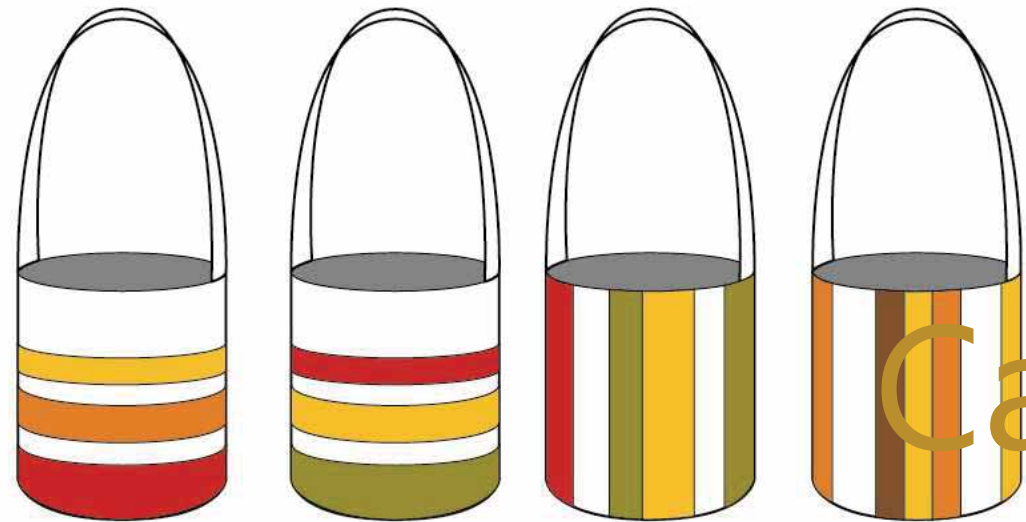

Fortalecimiento de tejidos tradicionales  
Estandarización de medidas  
uso de tintes naturales

Ca  
mi  
nos  
ENTRE EL CAMBIO  
Y LA PERMANENCIA

“PROGRAMA DE FORTALECIMIENTO PRODUCTIVO Y EMPRESARIAL PARA PUEBLOS INDÍGENAS DE COLOMBIA”

# Cumaríbo-Vestuario y accesorios



ENTRE EL CAMBIO  
Y LA PERMANENCIA.

Línea de mochilas

Referentes



Tendencias



Paleta de color  
Tonos y tintes  
naturales

PROPUESTA EN DISEÑO



Ca  
mi  
nos  
ENTRE EL CAMBIO  
Y LA PERMANENCIA

“PROGRAMA DE FORTALECIMIENTO PRODUCTIVO Y EMPRESARIAL PARA PUEBLOS INDÍGENAS DE COLOMBIA”



# Tuchín - Vestuario y accesorios



## CAMBIO

Línea de sobres en Caña flecha

Referentes



Tendencias



Paleta de color, gama con un complementario en contraste.

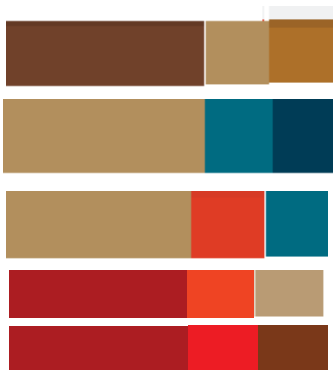

Diseños geométricos, franjas, entrecruzados, radiales.

## PROPUESTA EN DISEÑO

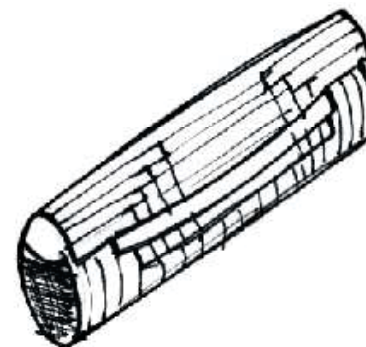
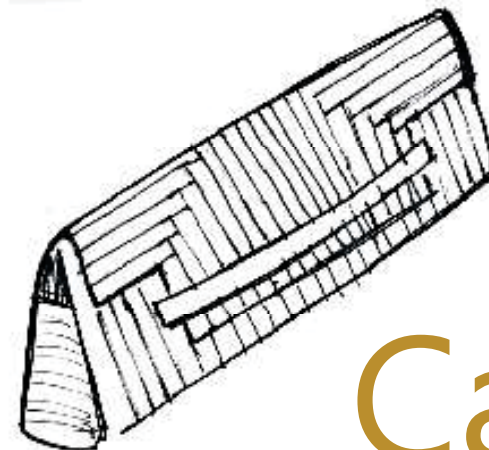
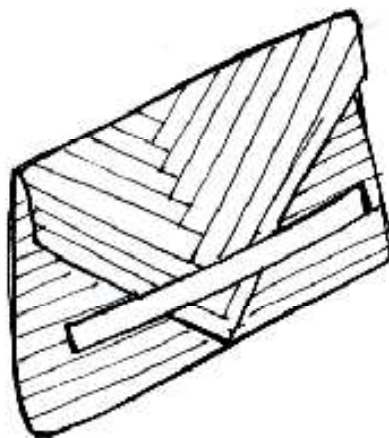

Ca  
mi  
nos  
ENTRE EL CAMBIO  
Y LA PERMANENCIA

“PROGRAMA DE FORTALECIMIENTO PRODUCTIVO Y EMPRESARIAL PARA PUEBLOS INDÍGENAS DE COLOMBIA”

# Tuchín - Vestuario y accesorios



## CAMBIO

Morrales elaborados en Caña flecha

### Referentes



### Tendencias



Morrales minimal

Paleta de color de los tonos de la lana natural



## PROPUESTA EN DISEÑO

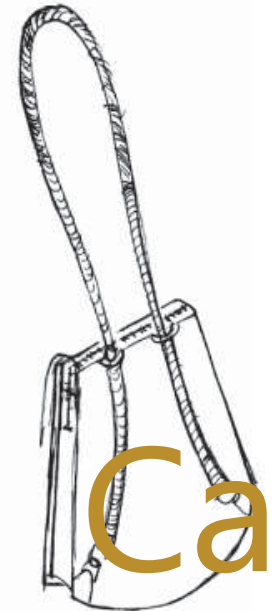

Morrales minimal con posibilidad de cambio a manos-libres

Morral rigido mediano	Base mayor 30 cms, base menor 26 cms, altura 30 cms
Morral rigido pequeño	Base mayor 25 cms, base menor 20 cms, altura 20 cms

Ca  
mi  
nos  
ENTRE EL CAMBIO  
Y LA PERMANENCIA



# accesorios



ENTRE EL CAMBIO  
Y LA PERMANENCIA.

Accesorios de moda : Ruanas – capas- Chalecos

Referentes

Tendencias



Patrones Gráficos - lineales -  
Saturación de texturas

Paleta de color  
lana natural

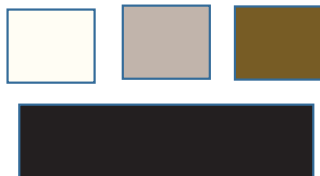

PROPUESTA EN DISEÑO

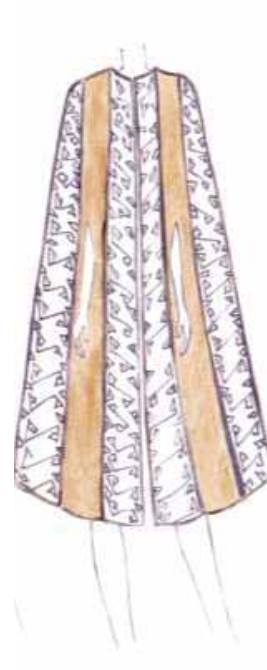

Ca  
mi  
nos  
ENTRE EL CAMBIO  
Y LA PERMANENCIA

“PROGRAMA DE FORTALECIMIENTO PRODUCTIVO Y EMPRESARIAL PARA PUEBLOS INDÍGENAS DE COLOMBIA”

# accesorios



ENTRE EL CAMBIO  
Y LA PERMANENCIA.

Accesorios de moda

Referentes



Tendencias



Paleta de color  
lana natural



PROPUESTA EN DISEÑO



Ca  
mi  
nos  
ENTRE EL CAMBIO  
Y LA PERMANENCIA

“PROGRAMA DE FORTALECIMIENTO PRODUCTIVO Y EMPRESARIAL PARA PUEBLOS INDÍGENAS DE COLOMBIA”



# accesorios



ENTRE EL CAMBIO  
Y LA PERMANENCIA.

Accesorios de moda

Referentes



Tendencias



Patrones Gráficos - lineales -  
Saturación de texturas

Paleta de color  
lana natural



PROPUESTA EN DISEÑO



mi  
nos  
ENTRE EL CAMBIO  
Y LA PERMANENCIA

“PROGRAMA DE FORTALECIMIENTO PRODUCTIVO Y EMPRESARIAL PARA PUEBLOS INDÍGENAS DE COLOMBIA”

# Jaikerazabi - Vestuario y accesorios



## CAMBIO

Tejeduría con chaquiras

### Referentes



Patrones Gráficos - lineales - Saturación de texturas

### Referentes gráficos

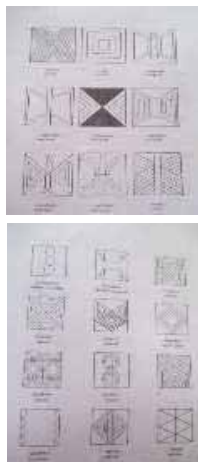

### Tendencias



### Paleta de color

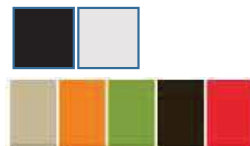

## PROPUESTA EN DISEÑO

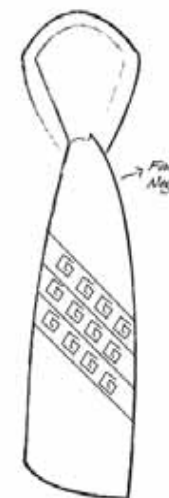
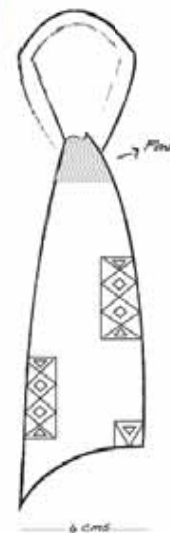
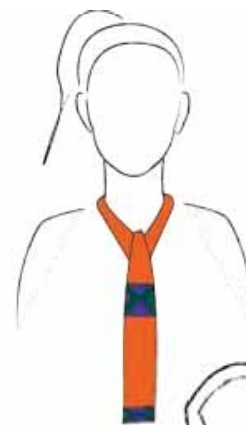

Cam  
mi  
nos  
ENTRE EL CAMBIO  
Y LA PERMANENCIA

“PROGRAMA DE FORTALECIMIENTO PRODUCTIVO Y EMPRESARIAL PARA PUEBLOS INDÍGENAS DE COLOMBIA”



# Pueblo Rico – Vestuario y accesorios



## CAMBIO

Tejeduría con chaquiras

Referentes



Tendencias



Paleta de color

## PROPUESTA EN DISEÑO

Línea de Okamas en dos formas y tres tamaños: redonda y triangular. Contraste de Color, Estandarización de medidas.



Ca  
mi  
nos  
ENTRE EL CAMBIO  
Y LA PERMANENCIA



artesanías  
de colombia



MINCIT



TODOS POR UN  
NUEVO PAÍS  
POR LA EQUIDAD Y LA PAZ

# Decoración y hogar

“PROGRAMA DE FORTALECIMIENTO PRODUCTIVO Y EMPRESARIAL PARA PUEBLOS INDÍGENAS DE COLOMBIA”



# San Francisco – Decoración y hogar



CAMBIO  
Línea hogar

PROPUESTA EN DISEÑO

Referentes



Tendencias



Paleta de color

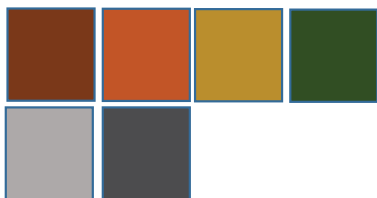

Composición de simbología  
gráfica de forma lineal

Cojín de piso



Otomano



Ca  
mi  
nos  
ENTRE EL CAMBIO  
Y LA PERMANENCIA

“PROGRAMA DE FORTALECIMIENTO PRODUCTIVO Y EMPRESARIAL PARA PUEBLOS INDÍGENAS DE COLOMBIA”

# Jaikerazabi – Decoración y hogar

## CAMBIO

Aplicación de tela sobre tela,  
en línea Ropa de Cama

### Referentes



### Tendencias



Altos contrastes

### Paleta de color

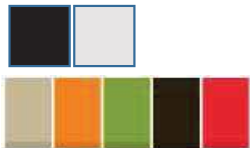

## PROPUESTA EN DISEÑO

Exaltar los detalles de la blusa de las mujeres Embera Katío los cuales tienen mucha carga cultural y están directamente relacionados con la naturaleza y su entorno, para crear una línea de Ropa de Cama.

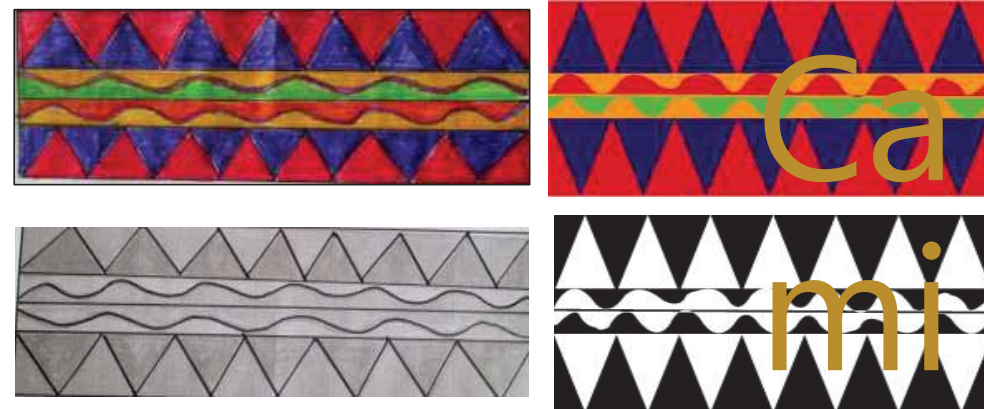

**nos**  
ENTRE EL CAMBIO  
Y LA PERMANENCIA



# Turbo – Decoración y hogar



## CAMBIO Molas geométricas Tule

### Referentes



### Tendencias



Estética  
Geométrica, brillo

Paleta de color



## PROPUESTA EN DISEÑO



Cojines 50 x 50 cm



Cojines 50 x 30 cm

Alto contraste y brillo  
Línea de Decoración

Ca  
mi  
nos  
ENTRE EL CAMBIO  
Y LA PERMANENCIA

# Turbo – Decoración y hogar



## PERMANENCIA

Cestería tradicional Tule

### Referentes



Exaltación técnica  
Contraste

### Tendencias



Paleta de color natural

## PROPUESTA EN DISEÑO

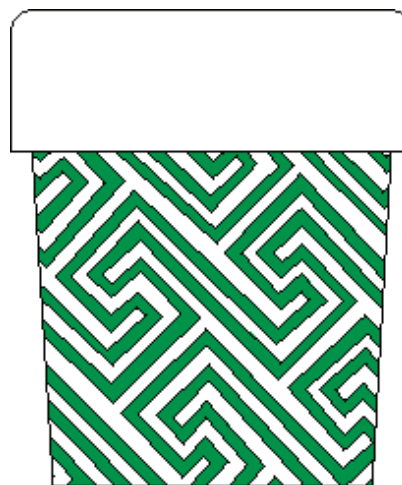

Línea de contenedores con y sin tapa



**Camino**  
ENTRE EL CAMBIO  
Y LA PERMANENCIA

“PROGRAMA DE FORTALECIMIENTO PRODUCTIVO Y EMPRESARIAL PARA PUEBLOS INDÍGENAS DE COLOMBIA”

# Turbo – Decoración y hogar

CAMBIO

Molas geométricas Tule

Referentes



Tendencias



Estética  
Geométrica, brillo

Paleta de color



Alto contraste y brillo  
Línea de Mesa



PROPUESTA EN DISEÑO



Individuales 45 x 35 cm

Ca  
mi  
nos  
ENTRE EL CAMBIO  
Y LA PERMANENCIA

“PROGRAMA DE FORTALECIMIENTO PRODUCTIVO Y EMPRESARIAL PARA PUEBLOS INDÍGENAS DE COLOMBIA”



# Chorrera – Decoración y hogar



## PERMANENCIA

Cestería tradicional Uitoto

### Referentes



### Tendencias



Saturación de texturas

Colores naturales con  
acentos



## PROPUESTA EN DISEÑO



Aplicación de simbología Uitoto

Formatos apilables

Ca  
mi  
nos  
ENTRE EL CAMBIO  
Y LA PERMANENCIA

“PROGRAMA DE FORTALECIMIENTO PRODUCTIVO Y EMPRESARIAL PARA PUEBLOS INDÍGENAS DE COLOMBIA”

# Guapi – Decoración y hogar



## PERMANENCIA

### Tejidos Tradicionales

#### Referentes

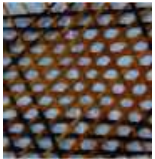

#### Tendencias



Alto Contraste

Colores naturales con contrastes fuertes, exploración de tonos satinados



## PROPUESTA EN DISEÑO



Recuperación de tejidos tradicionales  
Aplicación en Líneas de producto comercial  
Estandarización de medidas

Ca  
mi  
nos  
ENTRE EL CAMBIO  
Y LA PERMANENCIA

# Guapi – Decoración y hogar



## PERMANENCIA

### Canastos Tradicionales

#### Referentes



#### Tendencias



Contraste de texturas

Paleta de color  
Altos contrastes



## PROPUESTA EN DISEÑO

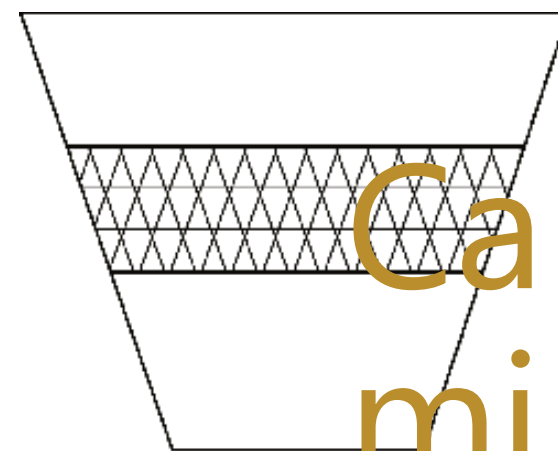
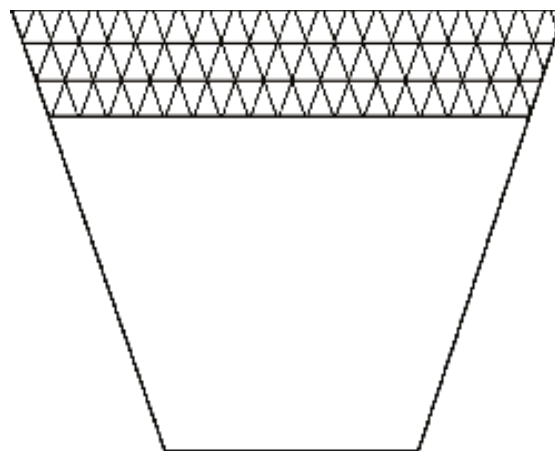

Ca  
mi  
nos  
ENTRE EL CAMBIO  
Y LA PERMANENCIA

“PROGRAMA DE FORTALECIMIENTO PRODUCTIVO Y EMPRESARIAL PARA PUEBLOS INDÍGENAS DE COLOMBIA”



# Coco Viejo – Decoración y hogar



## CAMBIO Cerámica y tejido

### Referentes



### Paleta de color Natural y tendencias



### Tendencias



### Contraste de texturas



### Perfección en la geometría, uso del color, generación de texturas

## PROPUESTA EN DISEÑO



### Desestructuración de la forma

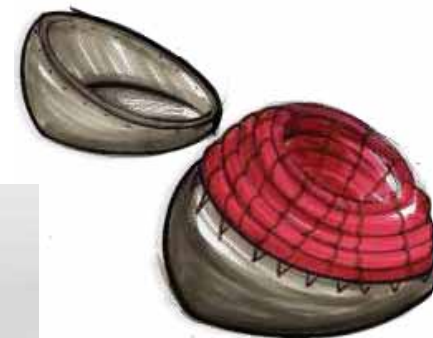

**nos**  
ENTRE EL CAMBIO  
Y LA PERMANENCIA

“PROGRAMA DE FORTALECIMIENTO PRODUCTIVO Y EMPRESARIAL PARA PUEBLOS INDÍGENAS DE COLOMBIA”

# Coco Viejo – Decoración y hogar



## CAMBIO

Cerámica y tejido

### Referentes



### Tendencias



Contraste de texturas

Paleta de color  
Natural y tendencias



## PROPUESTA EN DISEÑO

Integración de tejido por bandas

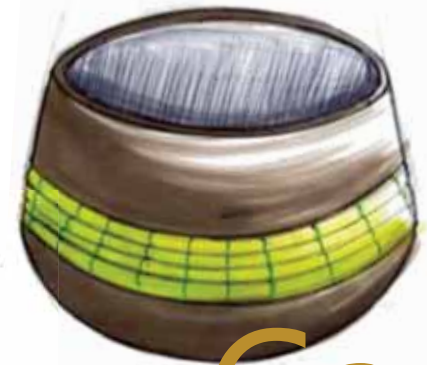

Ca  
mi  
nos  
ENTRE EL CAMBIO  
Y LA PERMANENCIA

“PROGRAMA DE FORTALECIMIENTO PRODUCTIVO Y EMPRESARIAL PARA PUEBLOS INDÍGENAS DE COLOMBIA”





artesanías  
de colombia



# Mesa y cocina

“PROGRAMA DE FORTALECIMIENTO PRODUCTIVO Y EMPRESARIAL PARA PUEBLOS INDÍGENAS DE COLOMBIA”



# San Francisco – Mesa y cocina



CAMBIO  
Línea mesa

PROPUESTA EN DISEÑO

Referentes



Tendencias



Paleta de color

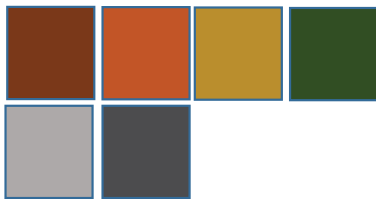

Composición de  
simbología grafica de  
forma lineal

Camino de mesa



Individuales

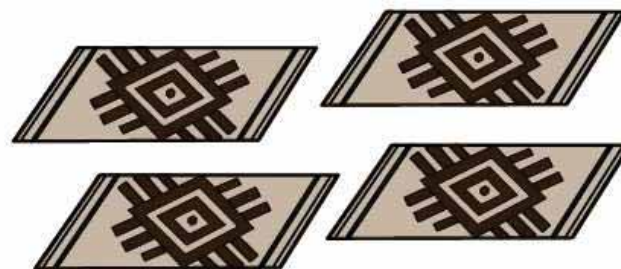

Ca  
mi  
nos  
ENTRE EL CAMBIO  
Y LA PERMANENCIA

“PROGRAMA DE FORTALECIMIENTO PRODUCTIVO Y EMPRESARIAL PARA PUEBLOS INDÍGENAS DE COLOMBIA”

# Guapi – Mesa y cocina



## PERMANENCIA Tejidos Tradicionales

### Referentes



### Tendencias



### Alto Contraste



### Paleta de color



## PROPUESTA EN DISEÑO



Recuperación y aplicación de tejidos  
en Línea de Mesa  
Alto contraste: color y textura  
Estandarización de medidas

- “PROGRAMA DE FORTALECIMIENTO PRODUCTIVO Y EMPRESARIAL PARA PUEBLOS INDÍGENAS DE COLOMBIA”

Ca  
mi  
nos  
ENTRE EL CAMBIO  
Y LA PERMANENCIA

# Tuchín – Mesa y cocina



## CAMBIO

Individuales elaborados en Caña flecha

### Referentes



### Tendencias

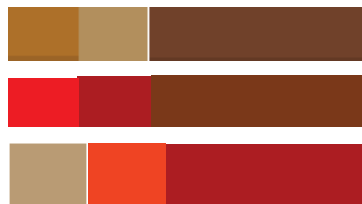

Paleta de color  
Tintes naturales

## PROPUESTA EN DISEÑO



Ca  
mi  
nos  
ENTRE EL CAMBIO  
Y LA PERMANENCIA

“PROGRAMA DE FORTALECIMIENTO PRODUCTIVO Y EMPRESARIAL PARA PUEBLOS INDÍGENAS DE COLOMBIA”



# Cumaribo – Mesa y cocina



## CAMBIO

Línea mesa

Referentes



Tendencias



Patrones geométricos



Contrastes de tono sobre tono

## PROPUESTA EN DISEÑO

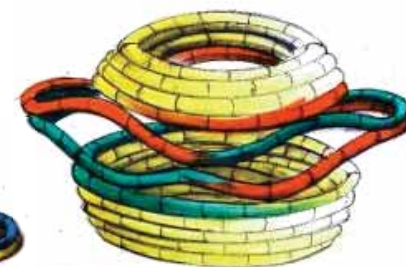

Paneras

Bomboneras

# Coco Viejo – Mesa y cocina



PERMANENCIA  
Línea cocina tradicional

Referentes



Paleta de color  
Colores naturales de la arcilla

Tendencias



Acabados rústicos y saturación de patrones gráficos

PROPUESTA EN DISEÑO



Evolución formal de producto tradicional

Aplicación de patrones gráficos

Ca  
mi  
nos  
ENTRE EL CAMBIO  
Y LA PERMANENCIA

- “PROGRAMA DE FORTALECIMIENTO PRODUCTIVO Y EMPRESARIAL PARA PUEBLOS INDÍGENAS DE COLOMBIA”



# Coco Viejo – Mesa y cocina



## PERMANENCIA

Línea cocina tradicional

### Referentes



Paleta de color

Colores naturales de la arcilla

### Tendencias



Acabados rústicos y saturación de patrones gráficos

## PROPUESTA EN DISEÑO

Intervención grafica



Kit de producto funcional

Caminos  
ENTRE EL CAMBIO  
Y LA PERMANENCIA

- “PROGRAMA DE FORTALECIMIENTO PRODUCTIVO Y EMPRESARIAL PARA PUEBLOS INDÍGENAS DE COLOMBIA”



# Mitú – Mesa y cocina



## CAMBIO Línea de Pocillos

### Referentes



### Tendencias



Grafismos geométricos  
y contrastes: liso -  
grabado, brillante-mate



Paleta de color: Bicolor, fondo  
negro con grafismos rojos

## PROPUESTA EN DISEÑO

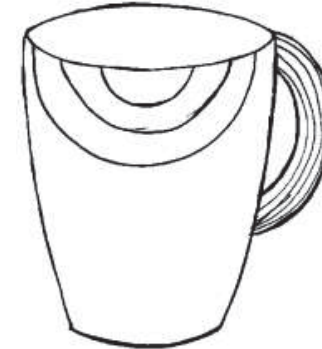

Pocillo	Diametro 8 cms , altura 9 cms
---------	-------------------------------

Ca  
mi  
nos  
ENTRE EL CAMBIO  
Y LA PERMANENCIA

# Mitú – Mesa y cocina



## PERMANENCIA

Línea de olla sopera, ensaladera y tazones.

### Referentes



### Tendencias



Grafismos geométricos,  
Contraste color  
plano y grafismos



Paleta de color: Bicolor,  
fondo negro con grafismos  
rojos



## PROPUESTA EN DISEÑO

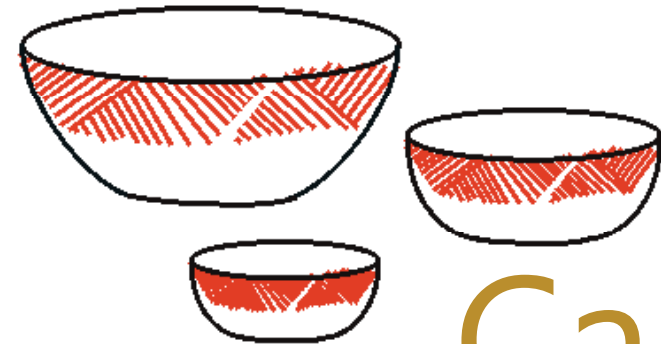

Olla	Diámetro mayor 30 cm x 30 cms
Ensaladera	Diámetro 23 cm x 10 cms
Tazón mediano	Diámetro 16 cm x 9 cms
Tazón pequeño	Diámetro 12 cm x 6 cms

Ca  
mi  
nos  
ENTRE EL CAMBIO  
Y LA PERMANENCIA

# Chorrera – Mesa y cocina



## CAMBIO

Contenedores pequeño formato

### Referentes



### Tendencias



Formas irregulares  
Asimétricas

Exploración otras  
maderas: Amarillo y  
Acapú  
Contraste de colores  
naturales



## PROPUESTA EN DISEÑO

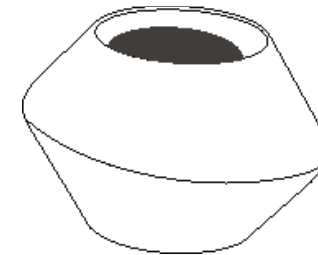
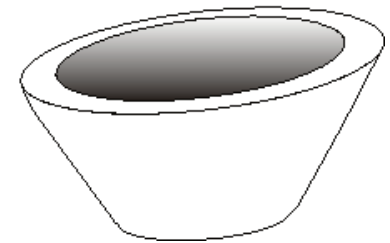
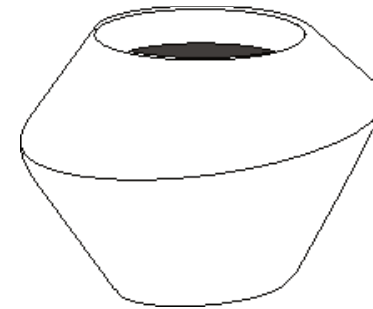

Ca  
mi  
nos  
ENTRE EL CAMBIO  
Y LA PERMANENCIA

“PROGRAMA DE FORTALECIMIENTO PRODUCTIVO Y EMPRESARIAL PARA PUEBLOS INDÍGENAS DE COLOMBIA”





artesanias  
de colombia



# Ca mi nos

ENTRE EL CAMBIO Y LA  
PERMANENCIA